



# EQUIPMENT GUIDE

PALLET TRUCKS • SCISSOR LIFTS • LIFT TABLES  
STACKERS • SELF-PROPELLED • STORE FIXTURES



**MOBILE**

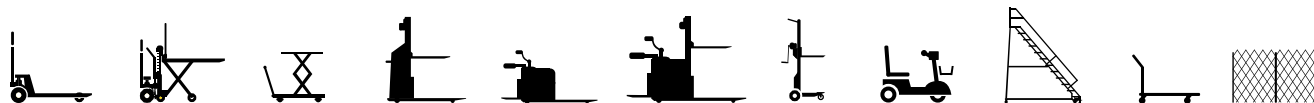



# WELCOME TO **M**OBILE

**Largest Range** of Manual Hand Pallet Trucks in North America  
and  
**Full Range** of Material Handling Products



<b>A Tradition of Quality Equipment Making</b>	<b>2</b>
Pallet Trucks	5
Scissor Lifts	25
Lift Tables	37
Stackers	43
Custom Stackers	61
Self-Propelled	67
Store Fixtures	111
<b>Service &amp; Support</b>	<b>128</b>
After Market Service	
Parts Depot	
Dealer Network	
DC Facilities	



# TABLE OF CONTENTS



**67**  
Self-Propelled

**111**  
Store Fixtures



# MOBILE

## JUST ONE PALLET TRUCK LAUNCHED A TRADITION

**For over 60 years, Mobile Industries Inc.  
has been helping you move your world.**

Back in the late 1950's, the Canadian pallet truck was virtually non-existent. There was only a few distributors of the product and no Canadian manufacturers. Joe Gardin (Founder), who at the time was in business making other industrial products, took advantage of a need in the marketplace. Noticing that the pallet trucks that were on the market were European imports and the fork sizes were all one standard length and width. He saw a business opportunity in providing alternatives to that standard pallet truck. Gardin began by simply cutting the forks off one of the standard models and making them longer, shorter, wider or narrower, depending on the customer's specifications. Soon, Gardin found himself manufacturing only pallet trucks, and together with the development of a pump assembly, the Mobile product line was officially introduced.

### **First in Industry to offer:**

- **2" Low-Profile and 1.5" Super Low-Profile Pallet Trucks**
- **4-Way Pallet Trucks**
- **Eccentric Adjustable Push Rods**
- **Application-Specific Designed Stackers**



Our strategic warehousing locations allow Mobile to provide fast, efficient, and cost-effective product movement around the world. Mobile offers its customers container logistics, less than container quantities, truck loads, and individual packages, and has established relationships and costs with carriers in all market regions. In an industry where “delivered pricing” is the standard, many of Mobile’s customers benefit from competitive positioning in the marketplace and feel that Mobile’s supply locations and shipping services are invaluable.

Mobile supports its dealers and clients with an extensive offering of custom design and paint options, as well as private product labelling. Mobile is proud to be long time partners with some of the largest material handling suppliers in the industry, providing them with the right product at the right price. This is what has kept Mobile going for more than 60 years and what will keep us going for the next 60!



**JOEGARDIN**  
Founder

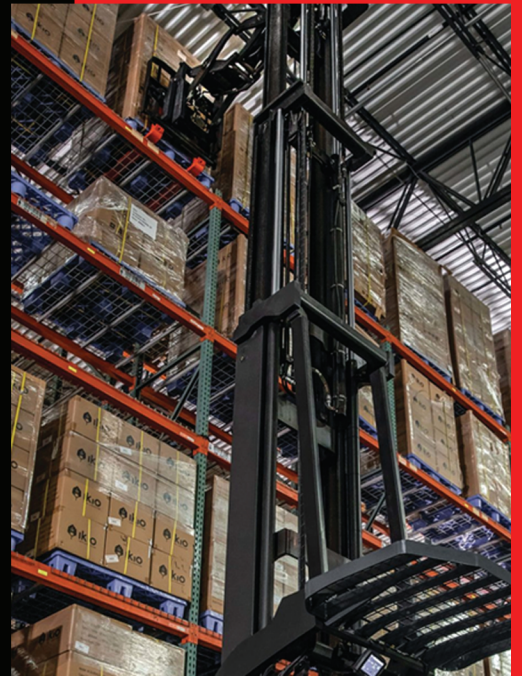

## **THIS IS WHY MOBILE:**

**Largest Range** of Manual Hand Pallet Trucks in North America

**Full Range** of Material Handling Products

**Strategic Stocking Locations** across North America

**Quick Ship** Products

**Competitive Ship** Rates

**MOBILE**



# PALLET TRUCKS

Premium <b>MLX55</b>	6-7	4-Way <b>MINEY</b>	15
Economy <b>ECO I-55</b>	8	Super Low Profile <b>MO</b>	16
Entry Level <b>IBT55</b>	9	Weigh Scale <b>ECO I-44WL</b>	17
Heavy Duty <b>ECO I-77</b>	10	Roll Truck <b>ECO ERT</b>	18
Heavy Duty <b>ECO I-11HD</b>	11	Rough Terrain <b>ECO RTT</b>	19
Galvanized <b>ECO I-55G</b>	12	Auto Brake <b>ECO I-55A</b>	20
Stainless Steel <b>ECO I-55SS</b>	13	<b>POWER DRIVE</b>	22-23
Low Profile <b>MINI</b>	14		



**TANDEM / LOAD BACKREST / QUICK LIFT PUMP / AUTO BRAKE  
4-WAY FORK DIMENSIONS / LOW & SUPER LOW PROFILE FORKS / WEIGH SCALE  
ROLL HANDLING FORKS / CORROSION RESISTANT / HEAVY DUTY / ROUGH TERRAIN**



**Best Usage**

- General lift and transport of standard pallets/skids (40"W x 48"L)
- Long and custom fork models to accommodate extended/awkward loads



**MLX55 PREMIUM PALLET TRUCK**

The Mobile MLX55 is the absolute standard in premium Pallet Truck technology. Featuring durability and versatility, the MLX55 now comes equipped with a Foot Release Mechanism, a unique Pump Piston Dust Cap, improved Bell Crank Design and one-piece reinforced Forks for greater strength.

SKU: MLX55

**5500 LBS**

**MLX55**  
**PREMIUM**



**Features**

- Heavy Duty One-Piece Double C-Channel Steel Frame
- Leak-Proof with Overload Capacity Hydraulic Pump
- Ergonomic 'Spring-A-Matic' Loop Handle
- Ambidextrous Handle Lever Allows Ease of Use For Both Left or Right-Handed Operators
- 200 Degree Steering Maneuverability
- Durable Powder Coat Paint Finish
- Adjustable Push Rods for Individual Fork Adjustment
- Helper Rollers For Easier Pallet Entry
- North American Designed

**Specifications**

Capacity (lbs):	5,500 (59" & 71" forks rated @ 4,400 lbs)
Fork Length:	35" / 48" / 59" / 71"
Fork Overall Width:	20.5" / 27"
Lowered Height:	2.9"
Raised Fork Height:	7.75"
Fork Width:	6.3"
Steer Wheels:	7" x 2"
Load Rollers Single:	2.9" x 3.7"
Wheels/Rollers:	Polyurethane
Weight (lbs):	175

**For custom colour and/or private labelling options, please contact Mobile direct @ 1 800 527 4612**



Pump Assembly



Handle



## MLX55 FEATURES

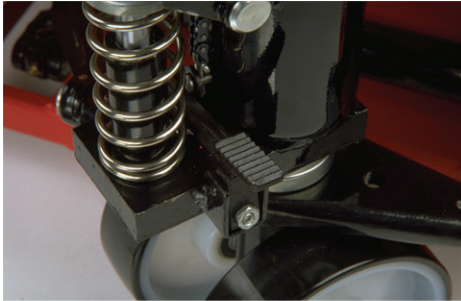

Foot Release Lever

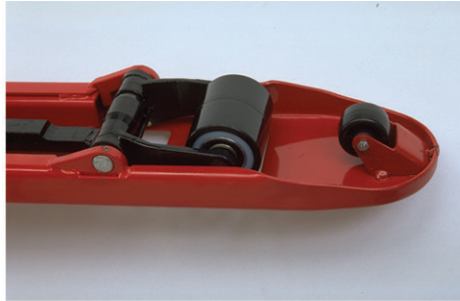

One Piece Hangar & Solid Fork Tip Design



Adjustable Push Rods

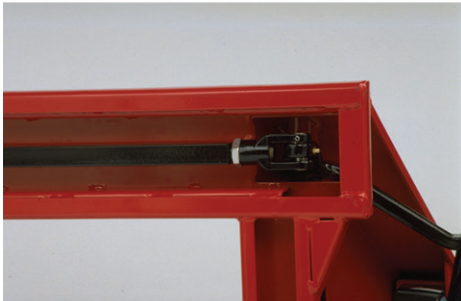

Reinforced Gussets and Frame



Reinforced Bulkhead Header



Left or Right-Handed Handle Lever



Quality Mobile Pump design



Reinforced Handle with Cushioned Control Lever



Reinforced Welds on Forks



**Best Usage**

- General lift and transport of standard pallets/skids (40"W x 48"L)
- Long and custom fork models to accommodate extended/awkward loads



**ECO I-55 ECONOMY PALLET TRUCK**

An economic alternative to the MLX55, the ECO I-55 features a quality German pump design for long shelf life and easy field servicing. 200 degree handle pivot provides exceptional maneuverability, with standard polyurethane wheels and rollers for transport ease. The I-55 features a powder coat finish, robotic welds throughout and grease fittings at all pivot points for easy maintenance.

SKU: ECO I-55, ECO I-44

**5500 LBS**  
**I-55**   
**ECONOMY**

**Features**

- Formed C-Channel Steel
- Reinforced Forks
- Quality Galvanized Pump
- Heavy Duty Thrust Plate
- Ergonomic Cushioned Handle
- 3-Position Finger Tip Control
- Poly Steer/Load Rollers
- Adjustable Push Rods
- High-Quality Powder Coat Finish

**Specifications**

Capacity (lbs):	5,500 / 4,400 (varies on fork size)
Fork Length:	32" / 35" / 42" / 48" / 59" / 71" / 98" / 118"
Fork Overall Width:	18" (32" length ONLY) / 20.5" / 27" / 40"
Lowered Height:	2.9" (3.3" for 4,400 lbs models)
Raised Fork Height:	7.5"
Fork Width:	6.3"
Steer Wheels	7" x 2"
Load Rollers Single:	2.9" x 3.7" (3.2" x 3.7" for 4,400 lbs models)
Wheels/Rollers:	Polyurethane (other types available)
Turning Radius:	52.5" (27" x 48" models only)
Weight (lbs):	175

<sup>1</sup>27" x 118" / Model: ECO I-44 (Equipped with Tandem Load Rollers)

**Options: Tandem Rollers (2.9" x 2.75") • Nylon or Steel Wheels • Rubber Steer Wheels • Auto Brake • Quick Lift • Load Backrest • 6,000 lbs Capacity (20.5"/27" x 48" ONLY)**



Pump Assembly

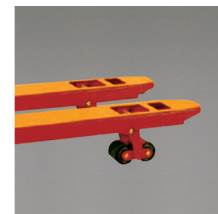

Tandem Rollers (Optional)



Load Backrest (Optional)



Best Usage  
 • General lift and transport of standard pallets/skids (40"W x 48"L)



### IBT55 ENTRY LEVEL PALLET TRUCK

IBT55 is the most affordable, and most dependable Pallet Truck in it's class. IBT55 is durable, versatile and easy to use, and is a more than suitable compliment to your transport equipment fleet.

SKU: IBT55

## 5500 LBS IBT55 ENTRY LEVEL



#### Features

- Formed C-Channel Steel
- Quality Powder Coat Pump
- Heavy Duty Thrust Plate
- Ergonomic Handle
- 3-Position Finger Tip Control
- Adjustable Push Rods
- High-Quality Powder Coat Finish

#### Specifications

Capacity (lbs):	5,500
Fork Length:	48"
Fork Overall Width:	20.5" / 27"
Lowered Height:	2.9"
Raised Fork Height:	7.5"
Fork Width:	6.3"
Steer Wheels:	7" x 2"
Load Rollers Single:	2.9" x 3.7"
Wheels/Rollers:	Polyurethane
Weight (lbs):	180

#### Options: Tandem Rollers (2.9" x 2.75") • Load Backrest



Pump Assembly

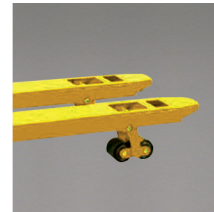

Tandem Rollers (Optional)



Load Backrest (Optional)



**Best Usage**

- General lift and transport of standard pallets/skids (40"W x 48"L)
- Heavy-duty loads



**ECO I-77 HEAVY DUTY PALLET TRUCK**

ECO I-77 Heavy Duty Pallet Truck is designed for extra heavy duty applications. It offers the same durability as the ECO I-55, but reinforced to handle loads of up to 7,700 lbs. Like the standard ECO I-55, the ECO I-77 offers 200 degree handle pivot for exceptional maneuverability in compact areas; comes with standard polyurethane wheels and heavy duty load rollers; features a powder coat finish; robotic welds throughout; and grease fittings at all pivot points for easy maintenance.

SKU: ECO I-77

**7700 LBS**  
**I-77**  
**HEAVY DUTY**



**Features**

- Formed C-Channel Steel
- Quality Galvanized Pump
- Heavy Duty Thrust Plate
- Ergonomic Cushioned Handle
- 3-Position Finger Tip Control
- Polyurethane Load Rollers
- Heavy Duty Push Rods
- High-Quality Powder Coat Finish

**Specifications**

Capacity (lbs):	7,700
Fork Length:	45" / 48"
Fork Overall Width:	21.25" / 27"
Lowered Height:	3.3"
Raised Fork Height:	7.9"
Fork Width:	6.3"
Steer Wheels:	7.9" x 1.96"
Load Rollers Single:	3.22" x 3.6"
Wheels/Rollers:	Polyurethane
Weight (lbs):	450

**For custom colour and/or private labelling options, please contact Mobile direct @ 1 800 527 4612**



Pump Assembly



Heavily Reinforced Forks/  
Push Rods



Best Usage

- General lift and transport of standard pallets/skids (40"W x 48"L)
- Heavy-duty loads

# 11000 LBS I-11HD HEAVY DUTY



**Features**

- Formed C-Channel Steel
- Quality Galvanized Pump
- Heavy Duty Thrust Plate
- Ergonomic Cushioned Handle
- 3-Position Finger Tip Control
- Nylon Load Rollers
- Heavy Duty Push Rods
- High-Quality Powder Coat Finish

**Specifications**

Capacity (lbs):	11,000
Fork Length:	45.2" / 48"
Fork Overall Width:	21.6" / 27"
Lowered Height:	3.3" / 2.9"
Raised Fork Height:	7.6" / 7.2"
Fork Width:	7" x 2.3"
Steer Wheels:	7" x 2"
Load Rollers Tandem:	3.15" x 2.75"
Wheels/Rollers:	Nylon
Weight (lbs):	330 / 374

**ECO I-11HD HEAVY DUTY PALLET TRUCK**

ECO I-11HD Heavy Duty Pallet Truck is designed for extra heavy duty applications. It offers the same durability as the ECO I-55, but reinforced to handle loads of up to 11,000 lbs. Like the standard ECO I-55, the ECO I-11HD offers 200 degree handle pivot for exceptional maneuverability in compact areas; comes with standard polyurethane wheels and heavy duty load rollers; features a powder coat finish; robotic welds throughout; and grease fittings at all pivot points for easy maintenance.

**For custom colour and/or private labelling options, please contact Mobile direct @ 1 800 527 4612**

SKU: ECO I-11HD



**Best Usage**

- High-hygiene environments (Pharmaceuticals, Fisheries, Clean-Room)
- Harsh effects of cold (temperatures to -10F) or highly corrosive environments



**ECO I-55G GALVANIZED PALLET TRUCK**

The ECO I-55G Galvanized Pallet Truck is the ideal choice for Clean-Room or Cold-Room environments, highly corrosive chemical applications, or applications where the unit requires regular wash downs. Hygienic, durable and easy to clean, the ECO I-55G features a 100% Galvanized Pump, Handle, Frame and components, and grease fittings at all pivot points for easy maintenance. The ECO I-55G features an ergonomic design that reduces operator fatigue and downtime. The 200 degree handle pivot provides exceptional maneuverability in compact areas and it comes with standard nylon wheels and rollers for rolling ease.

SKU: ECO I-55G

**5500 LBS**  
**I-55G**   
**GALVANIZED**

**Features**

- Reinforced Galvanized Forks
- German-Designed Galvanized Pump
- Heavy Duty Galvanized Thrust Plate
- Galvanized Cushioned Handle
- 3-Position Finger Tip Control
- Nylon Steer/Load Rollers
- Adjustable Galvanized Push Rods

**Specifications**

Capacity (lbs):	5,500
Fork Length:	48"
Fork Overall Width:	20.5" / 27"
Lowered Height:	2.9"
Raised Fork Height:	7.5"
Fork Width:	6.3"
Steer Wheels:	7" x 2"
Load Rollers Single:	2.9" x 3.6"
Wheels/Rollers:	Nylon
Weight (lbs):	200

**For private labelling options, please contact Mobile direct @ 1 800 527 4612**



Pump Assembly



Handle



**Best Usage**

- High-hygiene environments (Pharmaceuticals, Fisheries, Clean-Room)
- Harsh effects of cold (temperatures to -10F) or highly corrosive environments



**5500 LBS**  
**I-55SS**   
**STAINLESS STEEL**

**Features**

- Reinforced Stainless Forks
- German-Designed Stainless Pump
- Heavy Duty Stainless Thrust Plate
- Stainless Cushioned Handle
- 3-Position Finger Tip Control
- Nylon Steer/Load Rollers
- Adjustable Stainless Push Rods
- 304 Stainless Steel

**Specifications**

Capacity (lbs):	5,500
Fork Length:	48"
Fork Overall Width:	20.5" / 27"
Lowered Height:	2.9"
Raised Fork Height:	7.5"
Fork Width:	6.3"
Steer Wheels:	7" x 2"
Load Rollers Single:	2.9" x 3.6"
Wheels/Rollers:	Nylon
Weight (lbs):	200

**For private labelling options, please contact Mobile direct @ 1 800 527 4612**

**ECO I-55SS STAINLESS STEEL PALLET TRUCK**

ECO I-55SS Stainless Steel Pallet Truck is the ideal choice for Clean-Room or Cold-Room environments, highly corrosive chemical applications, or applications where the unit requires regular wash downs. Hygienic, durable and easy to clean, the ECO I-55SS features a 100% Stainless Steel Pump, Handle, Frame and components, and grease fittings at all pivot points for easy maintenance. The ECO I-55SS features an ergonomic design that reduces operator fatigue and downtime. The 200 degree handle pivot provides exceptional maneuverability in compact areas and it comes with standard nylon wheels and rollers for rolling ease.

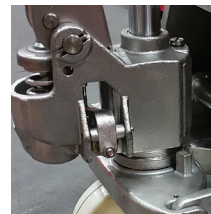

Pump Assembly

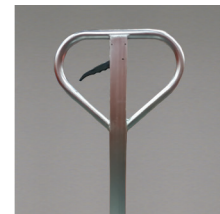

Handle

SKU: ECO I-55SS



**Best Usage**

- General lift and transport of standard pallets/skids (40"W x 48"L)
- Pallets with low clearance openings

**3300 LBS**  
**MINI**  
**LOW PROFILE**



**Features**

- Formed C-Channel Steel
- Reinforced Forks
- Quality Galvanized Pump
- Heavy Duty Thrust Plate
- Ergonomic Cushioned Handle
- 3-Position Finger Tip Control
- Adjustable Push Rods
- High-Quality Powder Coat Finish

**Specifications**

Capacity (lbs):	3,300
Fork Length:	45" / 48"
Fork Overall Width:	21" / 27"
Lowered Height:	2"
Raised Fork Height:	6.5"
Fork Width:	6.3"
Steer Wheels:	7" x 1.96"
Load Rollers Single:	1.96" x 3.66"
Wheels/Rollers:	Polyurethane / Steel
Weight (lbs):	175

**For custom colour and/or private labelling options, please contact Mobile direct @ 1 800 527 4612**

**ECO MINI LOW PROFILE PALLET TRUCK**

ECO 'MINI' Pallet Truck features a high quality pump for long life and easy field servicing. Durable, versatile and easy to use, its ergonomic design reduces operator fatigue and downtime. With a 2" lowered height and 21" or 27" wide forks, the ECO 'MINI' is designed to handle pallets where height restrictions are an issue; offers 200 degree handle pivot for exceptional maneuverability in compact areas; comes with standard polyurethane wheels and steel rollers for rolling ease; features a powder coat finish; robotic welds throughout; and grease fittings at all pivot points for easy maintenance.

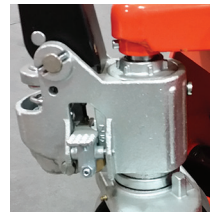

Pump Assembly



Load Rollers

SKU: ECO MINI





**Best Usage**

- General lift and transport of standard pallets/skids (40"W x 48"L)
- 4-way pallet entry
- Pallets with low clearance openings



**ECO MINEY 4-WAY PALLET TRUCK**

ECO 'MINEY' Pallet Truck features a high quality pump for long life and easy field servicing. Durable, versatile and easy to use, its ergonomic design reduces operator fatigue and downtime. With a 2" lowered height and 33" wide forks, the ECO 'MINEY' is designed to handle 4-way pallets; offers 200 degree handle pivot for exceptional maneuverability in compact areas; comes with standard polyurethane wheels and steel rollers for rolling ease; features a powder coat finish; robotic welds throughout; and grease fittings at all pivot points for easy maintenance.

**For custom colour and/or private labelling options, please contact Mobile direct @ 1 800 527 4612**

SKU: ECO MINEY

**3300 LBS**  
**MINEY**   
**4-WAY**

**Features**

- Formed C-Channel Steel
- Reinforced Forks
- Quality Galvanized
- Heavy Duty Thrust Plate
- Ergonomic Cushioned Handle
- 3-Position Finger Tip Control
- Adjustable Push Rods
- High-Quality Powder Coat Finish

**Specifications**

Capacity (lbs):	3,300
Fork Length:	48"
Fork Overall Width:	33"
Lowered Height:	2"
Raised Fork Height:	6.5"
Fork Width:	6.3"
Steer Wheels:	7" x 1.96"
Load Rollers Single:	1.96" x 3.66"
Wheels/Rollers:	Polyurethane / Steel
Weight (lbs):	200

**Specifications - OPTIONAL 4,400 lbs CAPACITY \*non-stock item**

Service Weight:	235.4
Steer Wheels:	Ø6.3" x 1.97"
Load Rollers (Single/Tandem):	Ø1.74" x 2.76"
Number of Wheels Front / Rear:	2 / 4
Height of Tiller:	46.46"
Lowered Height:	1.85"
Lift:	4.26"
Overall Length:	60.04"
Fork Dimensions:	6.97" x 1.38" x 48.04"
Distance Between Forks:	20.47" / 26.97" / 33"

Noise level is less than 70dB.

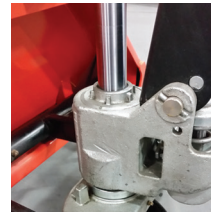

Pump Assembly



Handle



Side Pallet Entry

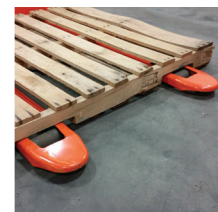

Side Pallet Entry



**Best Usage**

- General lift and transport of standard pallets/skids (40"W x 48"L)
- Pallets with low clearance openings



**ECO MO SUPER LOW PROFILE PALLET TRUCK**

ECO MO Low Profile Truck features an extra low 1 3/8" lowered height for applications that standard Pallet Trucks are unable to handle. With 20.5" or 27" wide forks, the ECO 'MO' is designed to handle loads with extreme entry height restrictions; offers 200 degree handle pivot for exceptional maneuverability in compact areas; comes with standard polyurethane wheels and steel rollers for rolling ease; features a powder coat finish; robotic welds throughout; and grease fittings at all pivot points for easy maintenance.

SKU: ECO MO

**2200 LBS**  
**MO**   
**SUPER LOW PROFILE**

**Features**

- Formed C-Channel Steel
- Reinforced Forks
- Quality Galvanized Pump
- Heavy Duty Thrust Plate
- Ergonomic Cushioned Handle
- 3-Position Finger Tip Control
- Adjustable Push Rods
- High-Quality Powder Coat Finish

**Specifications**

Capacity (lbs):	2,200
Fork Length:	44.1"
Fork Overall Width:	21" / 27"
Lowered Height:	1.4"
Raised Fork Height:	3.5"
Fork Width:	6.3"
Steer Wheels:	6.3" x 1.96"
Load Rollers Tandem (Steel):	1.33" x 2.28"
Wheels/Rollers:	Polyurethane / Steel
Weight (lbs):	175

**For custom colour and/or private labelling options, please contact Mobile direct @ 1 800 527 4612**



Load Rollers

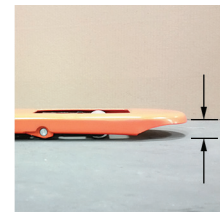

Low Profile



Best Usage  
 · Ability to lift, transport, and weigh loads

# 4400 LBS I-44WL WEIGH SCALE



## ECO I-44WL WEIGH SCALE PROFILE PALLET TRUCK

ECO I-44WL Weigh Scale Pallet Truck enables the operator to easily lift, weigh (to 99.9% accuracy) and transport loads. The easy to read meter features a high-contrast LCD display for better visibility, and 'clickable' keypad. The readout is available in metric or imperial and can be used with internal rechargeable battery source or external AC input. The ECO I-44WL features a quality German design pump for long life and easy field servicing. Durable, versatile and easy to use, it features an ergonomic design that reduces operator fatigue and downtime. A 195 degree handle pivot provides exceptional maneuverability in compact areas and comes with standard polyurethane wheels and rollers for rolling ease.

SKU: ECO I-44WL, ECO I-44WLP

### Features

- Easy-To-Use, Clickable Display Buttons
- High Contrast LCD Display
- Zero Correction, Gross Net Weighing/Total Weight Functions
- Auto Shut-Off after 3 minutes
- 1kg/2.2lb Increments
- High-Quality Powder Coat Finish
- Tare Function
- 70 Hrs Use
- Tolerance: +/-4.4lbs
- AA Batteries (4 x 1.5V)

### Specifications

Capacity (lbs):	4,400
Fork Length:	45" / 48"
Fork Overall Width:	22.5" / 27"
Lowered Height:	3.3"
Raised Fork Height:	7.8"
Fork Width:	7"
Overall Length:	62" / 65"
Battery:	(x4) DC 1.5V
Wheels/Rollers:	Polyurethane
Weight (lbs):	310

### Options: Thermal Printer (Model: ECO I-44WLP)

\*\*\* UNIT IS NOT LEGAL FOR TRADE \*\*\*



LCD Display



LCD Display Buttons



Pump Assembly



Best Usage  
 · Cradling paper rolls and other cylinder loads

# 4400 LBS ERT ROLL TRUCK



\*Please reference which fork width is needed for your roll diameter

Roll Diameter	16" - 24"	24" - 31.5"	31.5" - 47"	47" - 63"
Overall Fork Width	30"	33.5"	39.4"	45.3"

### Features

- Formed C-Channel Steel
- Inverted "V" Shaped Forks for Handling Rolls/Reels/Drums and more
- Quality Galvanized Pump
- Heavy Duty Thrust Plate
- Ergonomic Cushioned Handle
- 3-Position Finger Tip Control
- Polyurethane Steer Wheels/Load Rollers
- Adjustable Push Rods
- High-Quality Powder Coat Finish

### Specifications

Capacity:	4,400 lbs
Forks Length:	31" / 35" / 39" / 43" / 45" / 48"
Forks Overall Width:	30" / 33.5" / 39.4" / 45.3"
Lowered Height:	--
Raised Fork Height:	7.9"
Fork Width:	--
Steer Wheels:	8" x 2"
Load Rollers:	3" x 3.7"
Wheels/Rollers:	Polyurethane
Weight:	--

## ECO ERT ROLL TRUCK

ECO ERT Roll Trucks are designed to cradle paper, plastic, and rolls of various shapes and sizes. It offers the same durability as the ECO I-55, but its inverted "V" fork design lifts and transports rolls while protecting them from damage. Like the standard ECO I-55, the ECO ERT offers 200 degree handle pivot for exceptional maneuverability in compact areas; comes with standard polyurethane wheels and rollers for rolling ease; features a powder coat finish; robotic welds throughout; and grease fittings at all pivot points for easy maintenance.

For custom colour and/or private labelling options, please contact Mobile direct @ 1 800 527 4612

SKU: ECO ERT



Best Usage

- Soft/uneven surfaces, rugged surfaces, or high ground clearance requirements

## 2650 LBS RTT ROUGH TERRAIN



### ECO RTT ROUGH TERRAIN PALLET TRUCK

ECO RTT Rough Terrain Truck has large pneumatic tires that make it ideal for outdoor use or on undulating surfaces. Each fork is adjustable, allowing the truck to be used with pallets of different sizes as well as with either open or closed bottoms. This ECO Rough Terrain Truck also offers 210 degree handle pivot for exceptional maneuverability in compact areas; comes with pneumatic wheels for rolling ease; features a powder coat paint finish and robotic welds throughout.

#### Features

- Pneumatic Tires
- 34" Long Adjustable Forks
- 2" Lowered Height
- 3-Position Finger Tip Control
- High-Quality Powder Coat Finish

#### Specifications

Capacity (lbs):	2,650
Fork Length:	34"
Fork Overall Width:	9" - 29"
Lowered Height:	2"
Raised Fork Height:	9.2"
Fork Width:	4.5"
Leg I.D.:	50.3"
Overall Size (L x W x H):	54" x 63" x 47.24"
Steer Wheels:	10.4" x 3.1"
Load Rollers Single:	21.6" x 5.2"
Weight (lbs):	517

**For custom colour and/or private labelling options, please contact Mobile direct @ 1 800 527 4612**

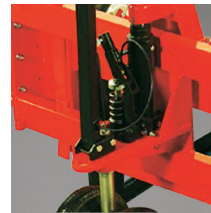

Pump Assembly

SKU: ECO RTT



Best Usage

- General lift and transport of standard pallets/skids (40"W x 48"L)
- Steep inclines

**5500 LBS**  
**I-55A**  
**AUTO BRAKE**



**Features**

- Auto Style Hand Brake
- Formed C-Channel Steel
- Quality Galvanized Pump
- Heavy Duty Thrust Plate
- Ergonomic Cushioned Handle
- 3-Position Finger Tip Control
- Polyurethane Load Rollers
- Adjustable Push Rods
- High-Quality Powder Coat Finish

**Specifications**

Capacity (lbs):	5,500
Fork Length:	48"
Overall Fork Width:	20.5" / 27"
Lift Height:	7.5"
Lowered Height:	3"
Fork Width:	6.25"
Steer Wheels:	7" x 2"
Load Rollers Single:	3" x 3.7"
Wheels/Rollers:	Rubber / Polyurethane
Weight (lbs):	180

**For custom colour and/or private labelling options, please contact Mobile direct @ 1 800 527 4612**

**ECO I-55A AUTO BRAKE PALLET TRUCK**

ECO I-55 w/Auto Brake features the same high quality pump for long life and easy field servicing as the standard ECO I-55 but with an Auto style drum braking system designed to allow the operator to slow or lock the unit in place. The ECO I-55 w/Auto Brake is designed to handle pallets where cargo is needed to be parked or locked into place, such as small inclines or declines; offers 200 degree handle pivot for exceptional maneuverability in compact areas; comes with standard rubber wheels and polyurethane rollers for rolling ease; features a powder coat paint finish; robotic welds throughout; and grease fittings at all pivot points for easy maintenance.



Pump Assembly



Handle (Optional)

SKU: ECO I-55A





# POWER DRIVE



## POWER DRIVE

The POWER DRIVE is a revolutionary, multi-patented invention consisting of a powerful, battery operated drive unit, and throttle assembly, that can be connected to any Mobile manual pallet truck model. The result is a safer, more convenient and more cost-effective means of moving pallets. Improve the productivity and safety of your pallet moving operations while maintaining a consistent operator interface - regardless of the age/brand/condition of the pallet trucks in operation. POWER DRIVE powered drive units also represent unprecedented value with a low purchase, minimal maintenance costs, and a continuous shelf-life.

### Features

- Unique "bolt-on" device that instantly converts a manual pallet truck into a powerful, fast, yet ultra-compact motorized truck
- Fits any Mobile model manual pallet truck
- So compact it can go wherever a manual pallet truck can
- Includes Power Drive Assembly Unit, Battery Pack, and Battery Charger

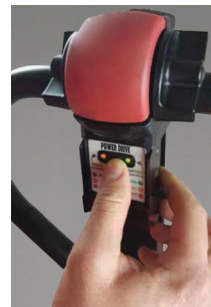

Control Handle

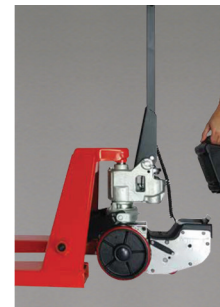

Battery Removed



Power Drive Assembly

SKU: POWER DRIVE



# POWER DRIVE FEATURES

**ECONOMICAL • COMPACT • POWERFUL • CONTINUOUS**



**UNPARALLED SAFETY FEATURES**  
 Multiple circuitry redundancy (including multiple E-Stop button activators); Hand-proximity confirmation on throttle activation (unit won't move without operator's hand on throttle); E-Stop circuitry is checked after each time the machine auto turns off.



**NEVER 'DOWN' FOR RECHARGING & NO MORE 'COLD BATTERY' ISSUES**  
 Instead of using large, heavy lead acid batteries that conventional electric trucks use, the POWER DRIVE uses compact, quick charge, quick change, 46V Nimh battery packs. They can be easily removed to minimize exposure to low temperatures when not in use, greatly improving battery performance.



**EXCEPTIONAL TECHNOLOGY FEATURES**  
 RPM-matched speed (consistent throttle response regardless of load); controlled hill descent, hill holding and hill-climb assist; 'intelligent' dynamic braking; smartphone configurable settings for accel/decel rates, max. speed, auto/manual horn; usage logging and more.



**SEPERATION OF 'TECHNOLOGY' FROM COMMODITY**  
 This patented concept allows the 'technology component', the POWER DRIVE unit, to be easily removed from the 'commodity component', a worn-out manual pallet truck, and moved over onto a new truck to start its next life. The result is that a POWER DRIVE sees a much longer service shelf life at a lower acquisition and annual cost.



**FLEXIBILITY TO CHANGE MODELS WITHOUT CHANGING YOUR POWER DRIVE**  
 An expanding library of (inexpensive) mounting plates are offered to allow attachment of the POWER DRIVE to an array of popular pallet trucks. Owners can easily switch between or mix different models of manual trucks over time while maintaining a consistent operator interface...the POWER DRIVE'S throttle and drive system.



**MINIMAL MAINTENANCE REQUIREMENTS**  
 The POWER DRIVE has been designed and built to be virtually maintenance free. The minimal amount of maintenance and parts required are inexpensive to purchase and easy to replace with no mechanical or electrical experience or special tools required.

WEIGHTS AND PERFORMANCE			POWER DRIVE PACKAGING SPECIFICATIONS		
Weight of Typical Manual Pallet Truck	150 lbs	70 kg	ITEMS INCLUDED	QTY	TOTAL PACKAGE (GROSS)
Weight of Power Pallet Truck with Battery Pack	38 lbs	17 kg	Machine	1	43 lbs   19.5 kg
Maximum Load Capacity (on flat concrete)	3,500 lbs	2,267 kg	Battery Charger	1	14 cm x 19 cm x 36 cm
Maximum Speed - Un-laden (on flat concrete)	3.7 mph	100 m/min	Battery Pack(s)	1	5.5" x 7.5" x 14"

\*Maximum speed and acceleration/deceleration times can vary depending on the load, gradient, surface conditions and condition of the pallet truck  
 \*\*Acceleration/deceleration factors, maximum speed setting, horn settings, and safety lock-outs can be set via a USB connection or, as an option, wirelessly from a smart phone

For more information on the POWER DRIVE, please contact Mobile direct @ 1 800 527 4612



# SCISSOR LIFTS

Manual <b>ECO EMSL22N</b>	26
Manual <b>ECO EMSL33N</b>	27
Stainless Steel <b>ECO EMSL22N-SS</b>	28
Stainless Steel <b>ECO EMSL33N-SS</b>	29
Battery <b>ECO EBSL22N</b>	30
Battery Stainless Steel <b>ECO EBSL22N-SS</b>	31
Battery <b>ECO EBSL33N</b>	33
Manual <b>MPS25</b>	34
Battery <b>BPS25</b>	35



**MANUAL PUMP / BATTERY OPERATED / STAINLESS STEEL**



**Best Usage**

- Built to work like a Pallet Truck/Stacker combined
- Eliminates bending/back injuries (will not work with bottom board pallets)

**2200 LBS**

# EMSL22N



**MANUAL**



**Features**

- Closed Fork Tips and Reinforced Chassis ensure long-lasting performance
- Ergonomically Designed and comfortable Handle
- Single Cylinder for increased durability and less maintenance
- Quick-Lift Function

**Specifications**

Capacity (lbs):	2,200
Fork Length:	46"
Overall Fork Width:	21.25" / 27"
Raised Fork Height:	31.5"
Extended Mast Height:	65.5"
Lowered Height:	3.3"
Overall Length:	70"
Fork Width:	6.3"
Aisle Width (32" x 47" Pallet):	78"
Turning Radius:	61.5"
Wheels/Rollers:	Polyurethane
Weight (lbs):	275 / 300

**EMSL22N MANUAL SCISSOR LIFT**

ECO EMSL22N Scissor Lifts are manual pump operated high lift truck designed to handle applications such as lifting and transporting skids and bottomless containers, loading/unloading conveyor systems, and is perfectly suited for use as a work station. Built to work like a Stacker and Pallet Truck combined, the ergonomic design of the EMSL22N helps prevent awkward bending and other stressful physical movements.

**For custom colour and/or private labelling options, please contact Mobile direct @ 1 800 527 4612**



Pump Assembly



Single Piston

SKU: EMSL22N



**Best Usage**

- Built to work like a Pallet Truck/Stacker combined
- Eliminates bending/back injuries (will not work with bottom board pallets)

# 3300 LBS EMSL33N HEAVY DUTY



**Features**

- Closed Fork Tips and Reinforced Chassis ensure long-lasting performance
- Ergonomically Designed and comfortable Handle
- Single Cylinder for increased durability and less maintenance
- Quick-Lift Function

**Specifications**

Capacity (lbs):	3,300
Fork Length:	43.3"
Overall Fork Width:	20.5" / 26.7"
Raised Fork Height:	31.5"
Extended Mast Height:	65.5"
Lowered Height:	3.3"
Overall Length:	70"
Fork Width:	6.3"
Aisle Width (32" x 47" Pallet):	78"
Turning Radius:	61.5"
Steer Wheels:	5.9" x 2"
Load Rollers Single:	2.9" x 2"
Wheels/Rollers:	Polyurethane
Weight (lbs):	275 / 300

**EMSL33N HEAVY DUTY MANUAL SCISSOR LIFT**

ECO EMSL33N Scissor Lifts are manual pump operated high lift truck designed to handle applications such as lifting and transporting skids and bottomless containers, loading/unloading conveyor systems, and is perfectly suited for use as a work station. Built to work like a Stacker and Pallet Truck combined, the ergonomic design of the EMSL33N helps prevent awkward bending and other stressful physical movements.

**For custom colour and/or private labelling options, please contact Mobile direct @ 1 800 527 4612**



Stabilizers



Handle

SKU: EMSL33N



**Best Usage**

- High-hygiene environments (Pharmaceuticals, Fisheries, Clean-Room)
- Harsh effects of cold (temperatures to -10F) or highly corrosive environments

# 2200 LBS EMSL22N-SS STAINLESS STEEL



**Features**

- Closed Fork Tips and Reinforced Chassis ensure long-lasting performance
- Pressure Relief Valve
- Ergonomic Cushioned Handle
- 3-Position Finger Tip Control
- Nylon Wheels/Load Rollers
- Hygienic, durable, easy to clean finish

**Specifications**

Capacity (lbs):	2,200
Fork Length:	45.3"
Overall Fork Width:	21.3" / 26.8"
Raised Fork Height:	31.5"
Lowered Height:	3.3"
Fork Width:	6.3"
Wheels/Rollers:	Nylon
Weight (lbs):	242 / 275

**EMSL22N-SS STAINLESS STEEL SCISSOR LIFT**

ECO EMSL Stainless Steel Scissor Lifts are designed for applications where high standards of hygiene or corrosive environments are present. They offer the same durability and quality as the standard EMSL22N Scissor Lifts, but designed to withstand environments where Stainless Steel is necessary.

SKU: EMSL22N-SS



**Best Usage**

- High-hygiene environments (Pharmaceuticals, Fisheries, Clean-Room)
- Harsh effects of cold (temperatures to -10F) or highly corrosive environments



**3300 LBS**  
**EMSL33N-SS**  
**STAINLESS STEEL**

**Features**

- Closed Fork Tips and Reinforced Chassis ensure long-lasting performance
- Pressure Relief Valve
- Ergonomic Cushioned Handle
- 3-Position Finger Tip Control
- Nylon Wheels/Load Rollers
- Hygienic, durable, easy to clean finish

**Specifications**

Capacity (lbs):	3,300
Fork Length:	45.3"
Overall Fork Width:	21.3" / 26.8"
Raised Fork Height:	31.5"
Lowered Height:	3.3"
Fork Width:	6.3"
Wheels/Rollers:	Nylon
Weight (lbs):	282 / 293

**EMSL33N-SS STAINLESS STEEL SCISSOR LIFT**

ECO EMSL Stainless Steel Scissor Lifts are designed for applications where high standards of hygiene or corrosive environments are present. They offer the same durability and quality as the standard EMSL33N Scissor Lifts, but designed to withstand environments where Stainless Steel is necessary.

SKU: EMSL33N-SS



**Best Usage**

- Built to work like a battery operated Pallet Truck/Stacker combined
- Eliminates bending/back injuries (will not work with bottom board pallets)



**EBSL22N BATTERY SCISSOR LIFT**

ECO EBSL22N Scissor Lifts are battery operated high lift truck designed to handle applications such as lifting and transporting skids and bottomless containers, loading/unloading conveyor systems, and is perfectly suited for use as a work station. Built to work like a Stacker and Pallet Truck combined, the ergonomic design of the EBSL22N helps prevent awkward bending and other stressful physical movements.

SKU: EBSL22N

**2200 LBS**  
**EBSL22N**   
**BATTERY**

**Features**

- Closed Fork Tips and Reinforced Chassis ensure long-lasting performance
- Ergonomically Designed and comfortable Handle
- Single Cylinder for increased durability and less maintenance
- Built-In Charger

**Specifications**

Capacity (lbs):	2,200
Fork Length:	46"
Overall Fork Width:	21.25" / 27"
Raised Fork Height:	31.5"
Extended Mast Height:	65.5"
Lowered Height:	3.3"
Overall Length:	67.5"
Fork Width:	6.3"
Aisle Width (32" x 47" Pallet):	78"
Turning Radius:	61.5"
Lift Motor (kW):	0.6
Battery Voltage (V/Ah):	12 / 52
Battery Weight (lbs):	24
Wheels/Rollers:	Polyurethane
Weight (lbs):	372

**For custom colour and/or private labelling options, please contact Mobile direct @ 1 800 527 4612**



Pump Assembly



Handle





**Best Usage**

- High-hygiene environments (Pharmaceuticals, Fisheries, Clean-Room)
- Harsh effects of cold (temperatures to -10F) or highly corrosive environments



**EBSL22N-SS STAINLESS STEEL BATTERY SCISSOR LIFT**

ECO EBSL Stainless Steel Battery Operated Scissor Lifts are designed for applications where high standards of hygiene or corrosive environments are present. They offer the same durability and quality as the standard EBSL22N Scissor Lifts, but designed to withstand environments where Stainless Steel is necessary.

SKU: EBSL22N-SS, EBSL33N-SS

**2200 LBS**  
**EBSL22N-SS**  
**STAINLESS STEEL BATTERY**

**Features**

- Closed Fork Tips and Reinforced Chassis ensure long-lasting performance
- Ergonomically Designed and comfortable Handle
- Single Cylinder for increased durability and less maintenance
- Built-In Charger

**Specifications**

Capacity (lbs):	2,200
Fork Length:	45.3"
Overall Fork Width:	21.3" / 26.8"
Raised Fork Height:	31.5"
Lowered Height:	3.3"
Overall Length:	67.5"
Fork Width:	6.3"
Aisle Width (32" x 47" Pallet):	78"
Turning Radius:	61.5"
Lift Motor (kW):	0.8
Battery Voltage (V/Ah):	12 / 60
Battery Weight (lbs):	24
Wheels/Rollers:	Nylon
Weight (lbs):	341 / 352

**Options: 3,300 lbs Capacity (Model#: EBSL33N-SS)**



Model shown: EBSL22N



**Best Usage**

- Built to work like a battery operated Pallet Truck/Stacker combined
- Eliminates bending/back injuries (will not work with bottom board pallets)



\*Picture shown is for representation purposes only and actual model differs

**EBSL33N HEAVY DUTY BATTERY SCISSOR LIFT**

ECO EBSL33N Scissor Lifts are battery operated high lift truck designed to handle applications such as lifting and transporting skids and bottomless containers, loading/unloading conveyor systems, and is perfectly suited for use as a work station. Built to work like a Stacker and Pallet Truck combined, the ergonomic design of the EBSL33N helps prevent awkward bending and other stressful physical movements.

SKU: EBSL33

**3300 LBS**  
**EBSL33N**  
**HEAVY DUTY**

**Features**

- Closed Fork Tips and Reinforced Chassis ensure long-lasting performance
- Built-In Charger
- Single Cylinder for increased durability and less maintenance
- Ergonomically Designed and comfortable Handle

**Specifications**

Capacity (lbs):	3,300
Fork Length:	43.3" / 44.8"
Overall Fork Width:	20.5" / 26.7"
Raised/Lowered Fork Height:	31.5" / 3.3"
Overall/Extended Mast Height:	49" / 65.5"
Overall Length:	67.5"
Fork Width:	6.3"
Aisle Width (32" x 47" Pallet):	78"
Turning Radius:	61.5"
Lift Motor (kW):	1.1
Battery Voltage (V/Ah):	12 / 63
Battery Weight (lbs):	24
Steer Wheels:	5.9" x 2"
Load Rollers Single:	2.9" x 2"
Wheels/Rollers:	Polyurethane
Weight (lbs):	323.4

**For custom colour and/or private labelling options, please contact Mobile direct @ 1 800 527 4612**



**Best Usage**

- Built to work like a Pallet Truck/Stacker combined
- Eliminates bending/back injuries (will not work with bottom board pallets)



**2500 LBS**  
**MPS25**   
**MANUAL**

**Features**

- Formed C-Channel Steel
- Steel Load Backrest
- Leak-proof Rebuildable Pump w/Overload Protect
- Automatic Brake System
- 3-Position Finger Tip Control Handle
- Dual Cylinder w/Chain Pull Design
- North American Designed

**Specifications**

Capacity (lbs):	2,500
Fork Length:	48"
Overall Fork Width:	20.5" / 27"
Raised Fork Height:	31.5"
Lowered Height:	3.5"
Fork Width:	7"
Steer Casters:	4" Phenolic
Load Rollers Single:	3" Nylon
Weight (lbs):	320

**For custom colour and/or private labelling options, please contact Mobile direct @ 1 800 527 4612**

**MPS25 MANUAL SCISSOR LIFT**

The Mobile MPS25 is a manually operated transport unit designed to handle applications such as: lifting/transporting skids and bottomless containers, loading/unloading conveyor systems, and as a mobile work station. Built to work like a combo Pallet Truck/Stacker, the MPS25 is a valuable tool in reducing worker injury due to poorly planned material handling procurement.

SKU: MPS25



**Best Usage**

- Built to work like a battery operated Pallet Truck/Stacker combined
- Eliminates bending/back injuries (will not work with bottom board pallets)



**BPS25 BATTERY SCISSOR LIFT**

The Mobile BPS25 features the same construction as the MPS25 but with built-in battery compartment. Reach maximum lift heights in 6 seconds and lift approximately 50 full loads to the full raised height on 1 battery charge.

SKU: BPS25

**2500 LBS**  
**BPS25**   
**BATTERY**

**Features**

- Formed C-Channel Steel
- Steel Load Backrest
- Leak-proof Rebuildable Pump w/Overload Protect
- Automatic Brake System
- Dual Cylinder w/Chain Pull Design
- Fully raised in 6 seconds
- Approx. 50 max. load lifts on 1 Battery Charge
- North American Designed

**Specifications**

Capacity (lbs):	2,500
Fork Length:	48"
Overall Fork Width:	20.5" / 27"
Raised Fork Height:	31.5"
Lowered Height:	3.5"
Fork Width:	7"
Battery Voltage (V/Ah):	12 / 125
Charger:	10A Onboard
Steer Casters:	4" Phenolic
Load Rollers Single:	3" Nylon
Weight (lbs):	450

**For custom colour and/or private labelling options, please contact Mobile direct @ 1 800 527 4612**

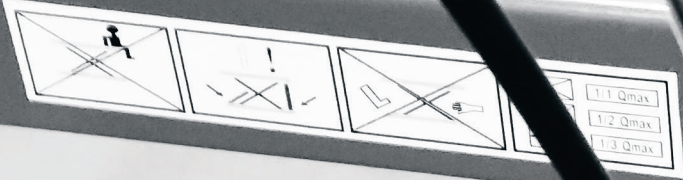

# LIFT TABLES

Foot Pump **ECO ELT SERIES** 38-39  
Stainless Steel **ELTSS** 40  
Electric **ECO EEL770** 41



**FOOT PUMP / STAINLESS STEEL / ELECTRIC**



**330-2200 LBS**

# ELT SERIES



**FOOT PUMP**



**Features**

- Lift and Transport Design
- Upper Lifting Limit Bypass
- Polyurethane Fixed and Swivel Wheels
- Dual Brake System
- Collapsible Handle (ELT330N, ELT660N, ELT1100N models)

**Specifications**

Capacity (lbs):	330 - 2,200
Lowered Height:	8.7" - 16.5"
Raised Height:	28.3" - 53.5"
Table Dimensions (L x W):	27.5" x 17.7" - 80" x 30"
Wheels (Diameter):	4" x 1" - 7" x 2"
Foot Pump Cycle to Max Height:	<27 - <200
Handle Height (from ground):	37.4" - 39.4"
Weight (lbs):	100 - 435

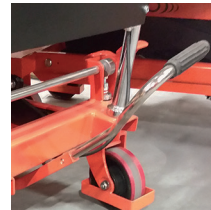

Foot Pump



Scissor Assembly

**ECO ELT SERIES LIFT TABLE**

The Mobile ECO Series of Lift Tables are lifting devices featuring easy, flexible, reliable and safe operation suitable for short distance transportation of loads in such applications as warehouses, manufacturing facilities, shopping malls and workshops.

SKU: ELT330N, ELT660N, ELT700N, ELT1100N, ELT1650N, ELT2200N, ELT1100GN, ELT2200GN





ELT330N



ELT660N



ELT770N



ELT1100N



ELT1650N



ELT1100GN

Specifications	Model# ELT330N	Model# ELT660N	Model# ELT770N	Model# ELT1100N	Model# ELT1650N	Model# ELT2200N	Model# ELT1100GN	Model# ELT2200GN
Capacity (lbs)	330	660	770	1100	1650	2200	1100	2200
Lowered Height	8.7"	11.2"	13.9"	11.2"	16.5"	15"	11.4"	14.2"
Raised Height	28.3"	34.6"	51.2"	34.6"	39"	39"	36"	53.5"
Table Dimensions (Length x Width)	27.5" x 17.7"	32" x 20"	36" x 20"	32" x 20"	40" x 20"	40" x 20"	63" x 32"	80" x 30"
Wheel (Diameter)	4" x 1"	5" x 1.6"	5" x 1.6"	5" x 1.3"	5.8" x 2"	5" x 2"	5" x 2"	7" x 2"
Foot Pump Cycle to Max Height	<28	<27	<53	<27	<45	<82	<55	<200
Net Weight (lbs)	100	170	231	178	275	308	339	435
Handle Height (from ground)	37.4"	39"	38.4"	39"	39"	38.6"	38.4"	39.4"



## 220-990 LBS **ELTSS** STAINLESS STEEL



ELT220SSN | ELT770SSN



ELT550SSN | ELT990SSN

### Features

- Lift and Transport Design
- Upper Lifting Limit Bypass
- Fixed and Swivel Wheels
- Dual Brake System
- Galvanized Pump and Scissors (ALL models)

### Specifications

Capacity (lbs):	220	550	770	990
Table Length:	27.55"	32"	35.82"	11.2"
Table Width:	17.52"	19.68"	19.68"	19.68"
Lowered Height:	9.84"	11.4"	13.9"	11.4"
Lift Height:	48"	35"	51"	35"

### ECO ELTSS STAINLESS STEEL LIFT TABLE

The Mobile ECO ELT Stainless Steel Lift Table is a lifting device featuring easy, flexible, reliable and safe operation suitable for short distance transportation of loads in such applications as warehouses, manufacturing facilities, shopping malls and workshops, where the unit is required to be washed down on a daily basis and a corrosion resistant exterior is needed.

SKU: ELT220SSN, ELT550SSN, ELT770SSN, ELT990SSN



# 770 LBS EELT770N ELECTRIC



## Features

- Electric Lift Operation
- Upper Lifting Limit Bypass
- Polyurethane Fixed and Swivel Wheels
- Dual Brake System
- (2) 12V/15A Batteries
- On-Board 24V/3A Charger
- 24V DC 0.8 KW Motor

## Specifications

Capacity (lbs):	770
Lowered Height:	14.5"
Raised Height:	51.2"
Table Dimensions (L x W):	36" x 20"
Wheel:	5" x 1.6"
Lifting Speed - Laden / Unladen (p/sec):	3.5" / 4.3"
Lowering Speed - Laden / Unladen (p/sec):	3.9" / 3.5"
Handle Height From Ground:	36.2"
Net Weight (lbs):	312

## ECO EELT770N ELECTRIC LIFT TABLE

The Mobile ECO EELT770N Electric Lift Table is a lifting device featuring easy, flexible, reliable and safe operation suitable for short distance transportation of loads in such applications as warehouses, manufacturing facilities, shopping malls and workshops. It's also the perfect solution for use as a feeding table on an assembly line.

SKU: EELT770N



# STACKERS

Semi-Electric <b>B-Series</b>	44
Telescopic <b>F-Series</b>	47
Electric Platform <b>EEP88</b>	48-49
Manual Platform <b>EMP88</b>	50
Manual Winch <b>MW500</b>	51
Manual Winch <b>MW750</b>	52
Manual Pump <b>EMS22</b>	53
Manual Pump <b>EMS22NFF</b>	54
Fixed Platform <b>EMS22NFP</b>	55
Self-Lifting <b>ESLS11</b>	56
Adjustable Fork <b>EHS22N</b>	57
Fixed Fork <b>EHS22FFN</b>	58
Fork-Over <b>EHS33FFN</b>	59



**FIXED STRADDLE / FORK-OVER / APPLICATION SPECIFIC / AC POWER  
5TH WHEEL FIXED PULL HANDLE / HAND REMOTE CONTROL  
SNAP-ON PLATFORM / MODIFIED FORK LENGTHS**

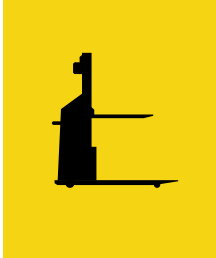

# 1500 LBS B-SERIES SEMI-ELECTRIC



## B-SERIES SEMI-ELECTRIC STACKER

The Mobile B-Series Stacker is designed to handle all types of applications including: lifting and transporting skids, bales, baskets; loading and unloading trucks; stocking shelves; die and mold handling; and can handle all sizes of pallets via adjustable straddle legs. The B-Series is most valuable for loading and unloading trucks where no loading docks exist.

SKU: B60CSA, B70CSA, B80CSA

### Features

- Formed Channel Steel Construction
- Adjustable Forks/Straddle Legs
- 6:1 Safety Factor Ensuring Safe Fork Lowering
- Steel Safety Screen
- On Dash Lift/Lower Lever
- Rebuildable Lift Cylinder for Easy Seals/Wiper Replacement
- Hand Controlled Floor-Lock Brake
- High-Quality Powder Coat Paint Finish
- North American Designed

### Specifications

Capacity (lbs):	1,500
Lowered Fork Height:	3"
Raised Fork Height:	60" / 70" / 80"
Overall Mast Height:	72" / 82" / 92"
Fork Dimensions:	4" x 42"
Forks Adjust:	8" - 24"
Straddle Legs I.D./O.D.:	41" - 50" / 47" - 56"
Turning Radius:	56.75" / 67" (w/5th Wheel Steering)
Steer Wheels:	6" Phenolic
Load Rollers Single:	4" Phenolic
Battery (V/Ah):	12 / 125 Heavy Duty
Charger (V/A):	12 / 10 (w/Overload Protect)
Weight (lbs):	625 / 638 / 652

**Options: 2,000 lbs Capacity • Fixed Straddle Legs • AC Power • Hand Remote • 5th Wheel Steering • Pull Handle • Snap-on Platform**

**\*\*\* Custom Options Available for Volume Oppourtunities \*\*\***

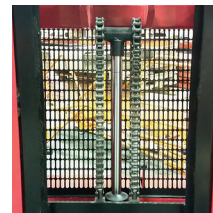

Lift Cylinder



Battery/Charger Compartment

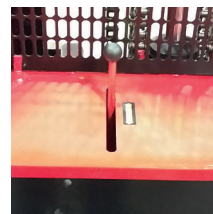

Lift/Lower Lever



Model shown: B60CSA



Model shown: FTAFC144



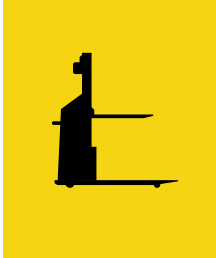

### F-SERIES TELESCOPIC SEMI-ELECTRIC STACKER

The Mobile F-Series Telescopic Stacker is perfectly suited for high reach, tight space applications. Equipped with power lift and easy to maneuver manual push/pull, the F-Series is designed to lift a variety of loads via adjustable straddle legs, is perfect for racking and shelving applications as well as loading/unloading trucks where docks do not exist.

SKU: FTAFC96, FTAFC120, FTAFC132, FTAFC144

# 1500 LBS F-SERIES TELESCOPIC

#### Features

- Formed Channel Steel Construction
- Adjustable Forks/Straddle Legs
- 6:1 Safety Factor Ensuring Safe Fork Lowering
- Steel Safety Screen
- On Dash Lift/Lower Lever
- Rebuildable Lift Cylinder for Easy Seals/Wiper Replacement
- Hand Controlled Floor-Lock Brake
- High-Quality Powder Coat Paint Finish
- North American Designed

#### Specifications

Capacity (lbs):	1,500
Lowered Fork Height:	3"
Raised Fork Height:	96" / 120" / 132" / 144"
Lowered Mast Height:	70" / 82" / 88" / 94"
Fork Dimensions:	4" x 42"
Forks Adjust:	8" - 25"
Straddle Legs I.D./O.D.:	36" - 50" / 42" - 56"
Turning Radius:	66" / 55.75" (NO 5th Wheel Steering)
Steer Wheels:	7" Polyurethane
Load Rollers:	4" Phenolic
Battery (V/Ah):	12 / 125 Heavy Duty
Charger (V/A):	12 / 10 (w/Overload Protect)
Weight (lbs):	815 / 875 / 900 / 924

- Options: 2,000 lbs Capacity (96" Lift) • Fixed Straddle Legs**  
**• AC Power • Hand Remote • 5th Wheel Steering**  
**• Pull Handle • Snap-on Platform**

\*\*\* Custom Options Available for Volume Oppourtunities \*\*\*

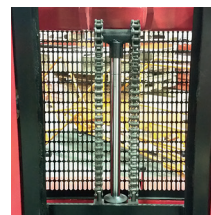

Lift Cylinder



5th Wheel Steering

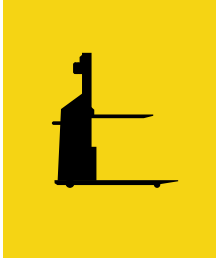

# 880 LBS EEP88 ELECTRIC PLATFORM

### Features

- Quick Lift Pump for Higher Efficiency
- Easy to Maneuver
- Small, Compact Footprint
- Works Great as a Work Platform (ie: Die Lifts)
- Non-Marking Casters

### Specifications

Capacity (lbs):	880
Raised Platform Height:	47" / 59"
Lowered Platform Height:	3.34" (7.87" Fixed Platform)
Maximum Height:	56.1" / 67.91"
Lifting Height (Max):	43.89" / 55.7"
Overall Width:	23.62"
Platform Length:	25.59"
Platform Width:	22.67"
Base Legs:	25.59" x 4.33"
Steer Casters:	5" x 1.57"
Load Rollers:	2.95" x 1.57"
Weight:	228.8 / 239.8
Lifting Speed (Un-laden/Laden):	7.28" / 3.15" (per sec.)
Lowering Speed (Un-laden/Laden):	0 ~ 2.95" / 0 ~ 4.52" (per sec)
Battery (V/Ah):	12 / 60 DC
Motor (V/W):	12 / 700 DC

## EEP88 ELECTRIC PLATFORM (FIXED / SNAP-ON) STACKER

ECO electric range of highly maneuverable, light duty lifts, are designed to take the strain out of any lifting job from ground level to over shoulder length.

### Residual Capacity at Different Lifting Heights

Up to (h3) in	Actual Capacity (Q) lbs	
	880	770
33.46"	880	770
47.24"	880	660
59.06"	880	550
Load Center (C) in	350	450



Ease of Operation with Lift/Lower Lever



(2) Non-Marking (standard) Swivel Casters

SKU: EEPS88-47, EEPS88-59, EEPS88-47

**CAP** 880 LBS **↑** 47" / 59" LIFT

**SPECIFICATIONS • PERFORMANCE**

ECO EEP88 SERIES ELECTRIC STACKER		SNAP-ON PLATFORM		FIXED PLATFORM
Model		EEPS88-47	EEPS88-59	EEPS88-47
Load Capacity / Rated Load	(Q) kg		400	400
Load Distance (center of drive axle to load wheel)	(c) mm		350	350
Wheelbase	(y) mm		809	785
Weight (including battery)	kg	104	109	106
Wheel Type		Nylon / Polyurethane		Rubber
Drive Wheel	mm		127 x 40	150 x 45
Load Rollers	mm		75 x 40	150 x 45
Wheels, Number (Front / Rear)		2 / 2		2 / 2
Tread (Front)	(b10) mm		480	480
Tread (Rear)	(b11) mm		415	425
Lowered Mast Height	(h1) mm	1425	1725	1330
Lift Height	(h3) mm	1200	1500	1200
Lowered Platform Height	(h13) mm		85	200
Overall Length	(l1) mm		1102	1065
Length to Face of Forks	(l2) mm		452	415
Overall Width	(b1) mm		600	570
Fork Dimensions (*Platform Dimensions)	(s/e/l) mm	50 / 110 / 650		*50 / 550 / 650
Platform Length	(l) mm		650	650
Platform Width	(b5) mm		576	550
Aisle Width (for pallets: 650 x 700 crossways)	(Ast) mm		1500	1480
Aisle Width (for pallets: 650 x 700 lengthways)	(Ast) mm		1500	1480
Turning Radius	(Wa) mm		1020	1000
Lift Speed (Laden / Un-laden)	mm/s		77 / 138	77 / 138
Lowering Speed (Laden / Un-laden)	mm/s		115 / 72	115 / 72
Parking Brake			Manual	Manual
Lift Motor Rating at S3 15%	kw		.8	.8
Battery Voltage, Nominal Capacity K5	V / Ah		12 / 60	12 / 60
Battery Weight	kg		15	15

\*Because of continual product improvements, specifications may be subject to change without notice

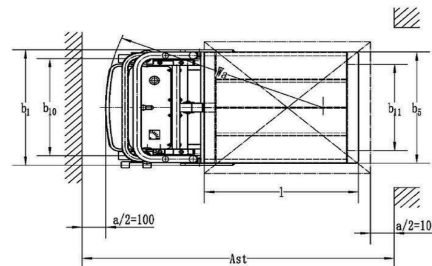
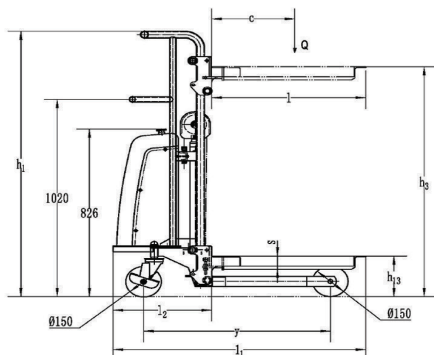
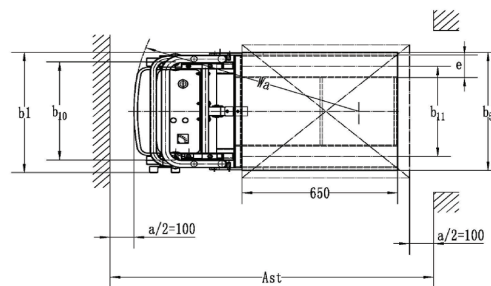
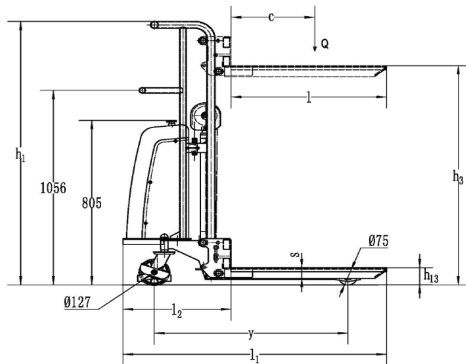

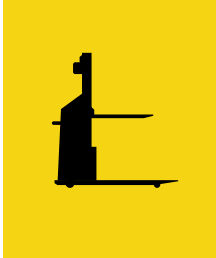

Model: EMFP88

## 880 LBS EMP88 MANUAL PLATFORM

### Features

- Heavy Duty Steel Construction
- Easy to Maneuver
- Small, Compact Footprint
- Works Great as a Work Platform (ie: Die Lifts)
- Non-Marking Casters
- Foot Pedal Lift Operation, Valve Lowering Operation

### Specifications

Capacity (lbs):	880
Raised Platform Height:	SEE CHART
Lowered Platform Height:	SEE CHART
Maximum Height::	SEE CHART
Lifting Height:	SEE CHART
Overall Width:	23.22" / 23.62"
Platform Length:	25.59"
Platform Width:	21.65" / 22.67"
Base Legs:	25.59" x 4.33"
Steer Casters:	5.9" x 1.57" / 5" x 1.57"
Load Rollers:	5.9" x 1.77" / 2.95" x 1.57"
Weight:	SEE CHART

### EMP88 MANUAL PLATFORM (FIXED / SNAP-ON) STACKER

Mobile's Manual Hydraulic Stackers provide users with a safe and efficient means of lifting and stacking pallets and other material goods. Each Manual Hydraulic Stacker is designed to lift and transport pallets and is ideal for unloading trucks in facilities without loading docks.

Specifications	Fixed Platform			Snap-On Platform		
	Model# EMFP88-33	Model# EMFP88-47	Model# EMFP88-59	Model# EMPS88-33	Model# EMPS88-47	Model# EMPS88-59
Raised Platform Height	33.46"	47.24"	59.05"	33.46"	47.24"	59.05"
Minimum Platform Height	7.87"	7.87"	7.87"	3.34"	3.34"	3.34"
Maximum Height	38.58"	52.36"	64.17"	37.6"	56.1"	67.91"
Lifting Height	25.6"	39.37"	51.18"	30.11"	43.89"	55.7"
Overall Length	48.51"	48.51"	48.51"	50"	50"	50"
Overall Width	23.23"	23.23"	23.23"	23.63"	23.63"	23.63"
Overall Height	38.59"	52.37"	64.18"	42.33"	56.11"	67.92"
Weight (lbs)	154	167.2	189.2	165	178.2"	200.2



Model: EMPS88

SKU: EMFP88-33, EMFP88-47, EMFP88-59, EMPS88-33, EMPS88-47, EMPS88-59

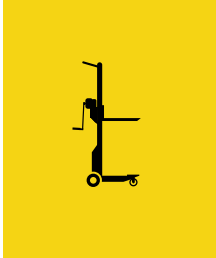

**500 LBS**  
**MW500**    
**MANUAL WINCH**



**Features**

- Solid Steel Construction
- Durable & Dependable
- Enables One-person Deliveries
- Designed for Use with Latest Containers
- Perfect for Lifting Material On/Off Trucks
- Reduces Risk of Injury
- North American Designed

**Specifications**

Capacity (lbs):	500
Raised Height:	54"
Overall Mast Height:	64"
Platform Size:	20" x 20"
Lowered Height:	4"
Front Casters:	3"
Rear Wheels:	6"
Casters/Wheels:	Phenolic
Weight (lbs):	98

**For custom colour and/or private labelling options, please contact Mobile direct @ 1 800 527 4612**

**MW500 MANUAL WINCH STACKER**

The Mobile MW500 is a versatile transport unit that can be used in the upright position or tilted back to climb stairs or obstructions. Simple to operate, the MW500 features 4 wheels, easy to maneuver steering and an easy to turn hand winch with automatic brake system. Unit includes: heavy-duty cable to ensure load/lifting safety; an easy-to-turn hand winch with an automatic braking system; a safety cage that protects the operator but still provides load and travel visibility; and phenolic fixed and swivel wheels for easy transport.

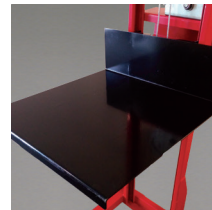

Platform

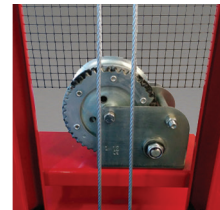

Cables



Push/Pull Handle



Mast

SKU: MW500

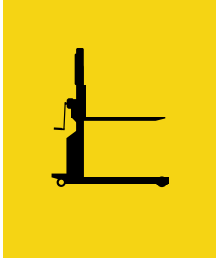

### MW750 MANUAL WINCH STACKER

The Mobile MW750 is a compact unit ideal for loading/unloading trucks where docks do not exist. The adjustable straddle legs enable the unit to handle pallets of any size without sacrificing ergonomics. Unit includes: heavy-duty cable to ensure load/lifting safety; an easy-to-turn hand winch with an automatic braking system; a safety cage that protects the operator but still provides load and travel visibility; and phenolic fixed and swivel wheels for easy transport.

SKU: MW750

# 750 LBS MW750 MANUAL WINCH



#### Features

- Formed Channel Steel Construction
- Adjustable Forks/Straddle Legs
- Steel Safety Screen
- Manual Hand Winch
- Locking Rear Casters
- High-Quality Powder Coat Paint Finish
- North American Designed

#### Specifications

Capacity (lbs):	750
Fork Dimensions:	3" x 36"
Forks Adjust O.D.:	6" - 24"
Straddle Legs I.D./O.D.:	34" - 50" / 40" - 56"
Lowered Fork Height:	3"
Raised Fork Height:	60"
Overall Mast Height:	70"
Load Rollers:	4" Phenolic
Rear Swivel Casters:	4" Phenolic
Weight (lbs):	355

For custom colour and/or private labelling options, please contact Mobile direct @ 1 800 527 4612



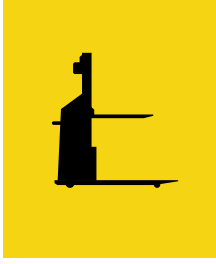

# 2200 LBS EMS22N MANUAL PUMP



**Features**

- Adjustable Forks/Straddle Legs
- Heavy Duty Steel Construction
- Hand or Foot Pump Operation
- Mechanical Parking Brake
- Lightweight/Compact
- High-Quality Powder Coat Paint Finish

**Specifications**

Capacity (lbs):	2,200
Lowered Fork Height:	2.75"
Raised Fork Height:	63" / 98" / 118"
Raised Mast Height:	78.15" / 120" / 139.76"
Lowered Mast Height:	78.15" / 72.25" / 82"
Mast Height Lift @ 50"/60":	<sup>1</sup> 96" / <sup>1</sup> 100.78"
Fork Dimensions:	4" x 36"
Forks Adjust O.D.:	8.5" x 33.5"
Straddle Legs I.D./O.D.:	36" - 48" / 43" - 54"
Straddle Leg Height:	5.51"
Overall Length:	56"
Load Rollers:	5" x 2.7"
Steer Casters:	7" x 2"
Weight (lbs):	705 / 795 / 850

<sup>1</sup>EMS22N-98 & EMS22N-118 models ONLY

**EMS22N MANUAL PUMP ADJUSTABLE FORK STACKER**

Mobile's Manual Hydraulic Stackers provide users with a safe and efficient means of lifting and stacking pallets and other material goods. Each Manual Hydraulic Stacker is designed to lift and transport pallets and is ideal for unloading trucks in facilities without loading docks.

**For custom colour and/or private labelling options, please contact Mobile direct @ 1 800 527 4612**

Specifications	Model# EMS22N-63	Model# EMS22N-98	Model# EMS22N-118
Raised Mast Height	78.15"	120"	139.76"
Lowered Mast Height	78.15"	72.25"	82"
Weight (lbs)	705	795	850

SKU: EMS22N-63, EMS22N-98, EMS22N-118

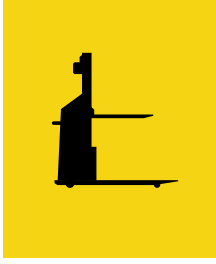

# 2200 LBS EMS22NFF MANUAL PUMP



**Features**

- Heavy Duty Steel Construction
- Hand or Foot Pump Operation
- Mechanical Parking Brake
- Lightweight/Compact
- High-Quality Powder Coat Paint Finish

**Specifications**

Capacity (lbs):	<sup>1</sup> 2,200
Lowered Fork Height:	3.3"
Raised Fork Height:	63" / 98"
Raised Mast Height:	78" / <sup>2</sup> 119.68"
Lowered Mast Height:	78" / <sup>2</sup> 71.85"
Overall Length:	63"
Overall Width:	28.55"
Overall Height:	80" / <sup>2</sup> 72.05"
Fork Length:	45"
Overall Fork Width:	21.6"
Straddle Legs I.D./O.D.:	14.4" / 24.6"
Load Rollers:	2.9"
Steer Casters:	7"
Weight (lbs):	484 / 660 / 572 (EMS33NFF-63)

<sup>1</sup>Available in 3,300 lbs (model#: EMS33NFF-63)

<sup>2</sup>EMS22NFF98 model

**EMS22NFF MANUAL PUMP FIXED FORK STACKER**

Mobile's Manual Hydraulic Stackers provide users with a safe and efficient means of lifting and stacking pallets and other material goods. Each Manual Hydraulic Stacker is designed to lift and transport pallets and is ideal for unloading trucks in facilities without loading docks.

Specifications	Model# EMS22NFF-63	Model# EMS22NFF-98	Model# EMS33NFF-63
Capacity (lbs)	2,200	2,200	3,300
Overall Length	63"	63"	63"
Overall Width	28.55"	28.55"	28.55"
Overall Height	80"	72.05"	80"

SKU: EMS22NFF-63, EMS22NFF-98, EMS33NFF-63



Handle



Foot Pump

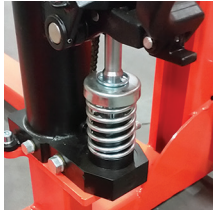

Pump Piston

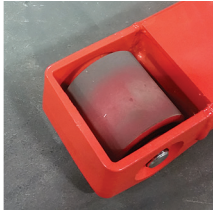

Load Roller



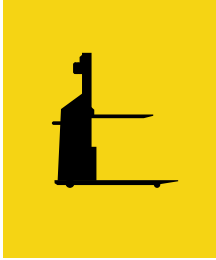

# 2200 LBS EMS22NFP FIXED PLATFORM



### Features

- Heavy Duty Steel Construction
- Hand or Foot Pump Operation
- Mechanical Parking Brake
- High-Quality Powder Coat Paint Finish
- Lightweight and Compact for easy maneuverability

### Specifications

Capacity (lbs):	<sup>1</sup> 2,200
Lowered Platform Height:	6"
Raised Platform Height:	63" / 98" / 118"
Raised Mast Height:	78" / <sup>2</sup> 119.68" / <sup>3</sup> 139.37"
Lowered Mast Height:	78" / <sup>2</sup> 71.85" / <sup>3</sup> 81.7"
Overall Length:	53.94"
Overall Width:	33.86"
Overall Height:	SEE CHART
Platform Dimensions (LxW):	30" x 32"
Base Legs I.D./O.D.:	28" / 34"
Load Rollers:	5"
Steer Casters:	7"
Weight (lbs):	490 / 580 / 665 / 715

<sup>1</sup> Available in 3,300 lbs (model#: EMS33NFP-63)

<sup>2</sup>EMS22NFP-98 model | <sup>3</sup>EMS22NFP-118 model

## EMS22NFP MANUAL PUMP FIXED PLATFORM STACKER

Mobile's Manual Hydraulic Stackers provide users with a safe and efficient means of lifting and stacking pallets and other material goods. Each Manual Hydraulic Stacker is designed to lift and transport pallets and is ideal for unloading trucks in facilities without loading docks.

Specifications	Model# EMS22NFP-63	Model# EMS33NFP-63	Model# EMS22NFP-98	Model# EMS22NFP-118
Capacity (lbs)	2,200	3,300	2,200	2,200
Overall Length	53.94"	53.94"	53.94"	53.94"
Overall Width	33.86"	33.86"	33.86"	33.86"
Overall Height	79.53"	81.5"	69.69"	84.26"



Handle



Foot Pump

SKU: EMS22NFP-63, EMS22NFP-93, EMS22NFP-118, EMS33NFP-63

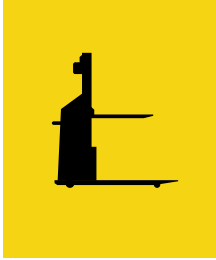

# 1100 LBS ESLS11 SELF-LIFTING



## ESLS11 SELF-LIFTING FORK-OVER STACKER

The ECO Self-Lift Stacker is an innovation and unique choice for delivery of goods, with one product able to replace your Tail-lift, Hand Pallet Truck, Stacker, Ramp and Swing lift. It is easy and quick to transport, by loading itself into your Van, Pick-up, Lorry, or Trailer (with or without a load on the forks), so that there will be no unloading or reloading problems at your destination, which increases efficiency significantly and makes deliveries easier and faster.

For video demonstration, scan the QR Code or visit: [mobilept.com/product/eco-esls11-self-lifting-fork-battery-operated-hydraulic-stacker/](https://mobilept.com/product/eco-esls11-self-lifting-fork-battery-operated-hydraulic-stacker/)



### Features

- Unique self-lift design allows operator to lift/lower the entire load on/off of delivery trucks
- Fork-Over Design
- Battery Operated Lift, Manual Push-Pull
- Easy Grip Handle allows easy/safe stacker movement
- Heavy Duty Steel Construction
- Built in charger
- Lift/Lower buttons located on handle and stacker body for easy operation no matter where the operator is standing
- Lightweight/Compact for easy maneuverability
- High-Quality Powder Coat Paint Finish

### Specifications

Capacity (lbs):	1,100
Lowered Fork Height:	3.15"
Raised Fork Height:	31.5" / 51"
Lowered Mast Height:	46.5" / 66.2"
Raised Mast Height:	78.3" / 118.1"
Fork Length:	41.3"
Overall Fork Width:	21.2"
Load Rollers:	2.36"
Steer Casters:	5"
Battery (V/Ah):	12 / 42
Weight (lbs):	609.4 / 666



SKU: ESLS11

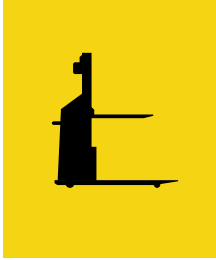

# 2200 LBS EHS22N ADJUSTABLE FORK



## ECO EHS22N SEMI-ELECTRIC ADJUSTABLE FORK STACKER

Mobile's Battery Hydraulic Stackers provide users with a safe and efficient means of lifting and stacking pallets and other material goods. Each Battery Hydraulic Stacker is designed to lift and transport pallets and is ideal for unloading trucks in facilities without loading docks.

Specifications	Model# EHS22N-63	Model# ETHS22N-98	Model# ETHS22N-118
Raised Mast Height	80.5"	122"	141.5"
Lowered Mast Height	80.5"	73"	82.8"
Weight (lbs)	1,430	1,562	1,606

### Features

- Adjustable Forks/Straddle Legs
- Battery Operated Lift/Manual Push-Pull
- Easy Grip Handle allows easy/safe stacker movement
- Heavy Duty Steel Construction
- Mechanical Parking Brake
- Lightweight/Compact
- High-Quality Powder Coat Paint Finish

### Specifications

Capacity (lbs):	2,200
Lowered Fork Height:	2.75"
Raised Fork Height:	63" / 98.5" / 118"
Raised Mast Height:	80.5" / 122" / 141.5"
Lowered Mast Height:	80.5" / 73" / 82.8"
Fork Length:	45"
Forks Adjust O.D.:	7.9" - 31.5"
Straddle Legs I.D./O.D.:	42.5" - 50.5" / 51" - 59"
Overall Length:	71"
Aisle Width (1000 x 1200mm pallets):	93.78"
Aisle Width (800 x 1200mm pallets):	88.66"
Turning Radius:	62.2"
Lifting Speed - Laden / Unladen (p/sec):	3.5" / 5.5"
Lowering Speed - Laden / Unladen (p/sec):	4.72" / 3.93"
Lift Motor (Kw):	1.5
Battery (V/Ah):	12 / 150
Battery Weight (lbs):	99
Load Rollers:	3 1/8"
Steer Casters:	7"
Weight (lbs):	1,430 / 1,562 / 1,606



Pull Handle

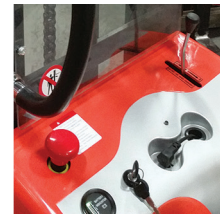

Console

SKU: EHS22N-63, ETHS22N-98, ETHS22N-118

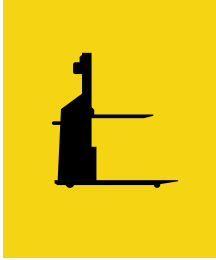

# 2200 LBS EHS22FFN FIXED FORK



### Features

- Fork-Over Design
- Battery Operated Lift/Manual Push-Pull
- Easy Grip Handle allows easy/safe stacker movement
- Heavy Duty Steel Construction
- Mechanical Parking Brake
- Lightweight/Compact
- High-Quality Powder Coat Paint Finish

### Specifications

Capacity (lbs):	2,200
Lowered Fork Height:	3.3"
Raised Fork Height:	63" / 98" / 118"
Raised Mast Height:	78" / 120.8" / 140.5"
Lowered Mast Height:	78" / 72" / 81.9"
Fork Length:	43.3"
Overall Fork Width:	22.4"
Overall Length:	67.7"
Load Rollers (Tandem):	2.9" x 2.75"
Steer Casters:	7" x 2"
Battery (V/Ah):	12 / 150
Weight (lbs):	726 / 902 / 946

## ECO EHS22FFN SEMI-ELECTRIC FIXED FORK STACKER

Mobile's Battery Hydraulic Stackers provide users with a safe and efficient means of lifting and stacking pallets and other material goods. Each Battery Hydraulic Stacker is designed to lift and transport pallets and is ideal for unloading trucks in facilities without loading docks.

Specifications	Model# EHS22FFN-63	Model# ETHS22FFN-98	Model# ETHS22FFN-118
Raised Mast Height	78"	120.8"	140.5"
Lowered Mast Height	78"	72"	81.9"
Weight (lbs)	726	902	946



Pull Handle



Console



Operator Foot Protection/  
Mechanical Parking Brake

SKU: EHS22FFN-63, ETHS22FFN-98, ETHS22FFN-118

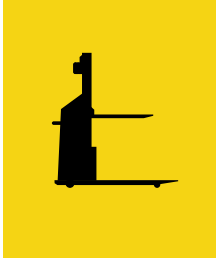

# 3300 LBS EHS33FFN FORK-OVER



### Features

- Fork-Over Design
- Battery Operated Lift/Manual Push-Pull
- Easy Grip Handle allows easy/safe stacker movement
- Heavy Duty Steel Construction
- Mechanical Parking Brake
- Lightweight/Compact
- High-Quality Powder Coat Paint Finish

### Specifications

Capacity (lbs):	3,300
Lowered Fork Height:	3.3"
Raised Fork Height:	62.9" - 137.79"
Overall Mast Height:	77.9" - 158.26"
Fork Length:	43.3"
Overall Fork Width:	22.4"
Overall Width:	30"
Overall Length:	67.9"
Load Rollers:	2.9" x 2.75"
Drive Wheel:	7" x 1.96"
Battery (V/Ah):	12 / 150
Weight (lbs):	959.2 - 1,218

## ECO EHS33FFN SEMI-ELECTRIC FORK-OVER STACKER

Mobile's Battery Hydraulic Stackers provide users with a safe and efficient means of lifting and stacking pallets and other material goods. Each Battery Hydraulic Stacker is designed to lift and transport pallets and is ideal for unloading trucks in facilities without loading docks.

Specifications	Model# EHS33FFN -63	Model# ETHS33FFN -98	Model# ETHS33FFN -118	Model# ETHS33FFN -137	Model# ETHS33FFLN -114
Raised Mast Height	77.9"	118.89"	138.58"	158.26"	138.58"
Lowered Mast Height	77.9"	70"	79.9"	89.7"	79.9"
Free Lift	0	0	0	0	58.66"
Weight (lbs)	959.2	1,135.2	1,194.6	1,254	1,218



Pull Handle

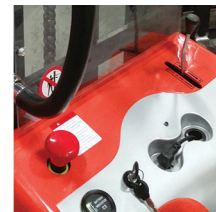

Console



Operator Foot Protection/  
Mechanical Parking Brake

SKU: EHS33FFN-63, ETHS33FFN-98, ETHS33FFN-118, ETHS33FFN-137, ETHSFFLN-114

# 6 MOBILE



10

**⚠️**

Reverse polarity battery  
 TEFU type (200Ah type S) battery  
 each. Underlies and underlaying battery  
 as high bonding and stability. You could be  
 accident. Connect battery as shown.

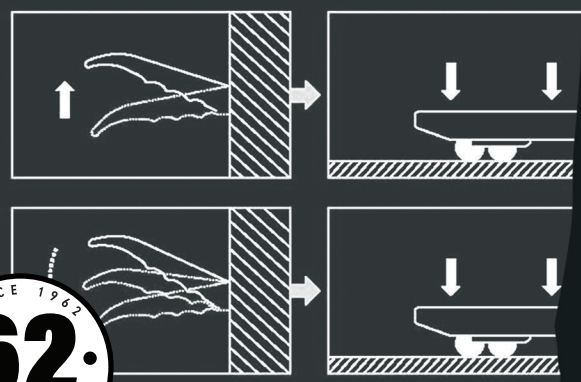

# CUSTOM STACKERS

Folding Mast <b>B76CFP-FM</b>	62
Folding Mast w/Basket <b>B65CFP-FMB</b>	63
Fixed Straddle Legs <b>FTAF173</b>	64
On-Board Tote <b>OBST500</b>	65



**FOLDING MAST / FOLDING MAST W/BASKET / FIXED STRADDLE / ON-BOARD TOTE**

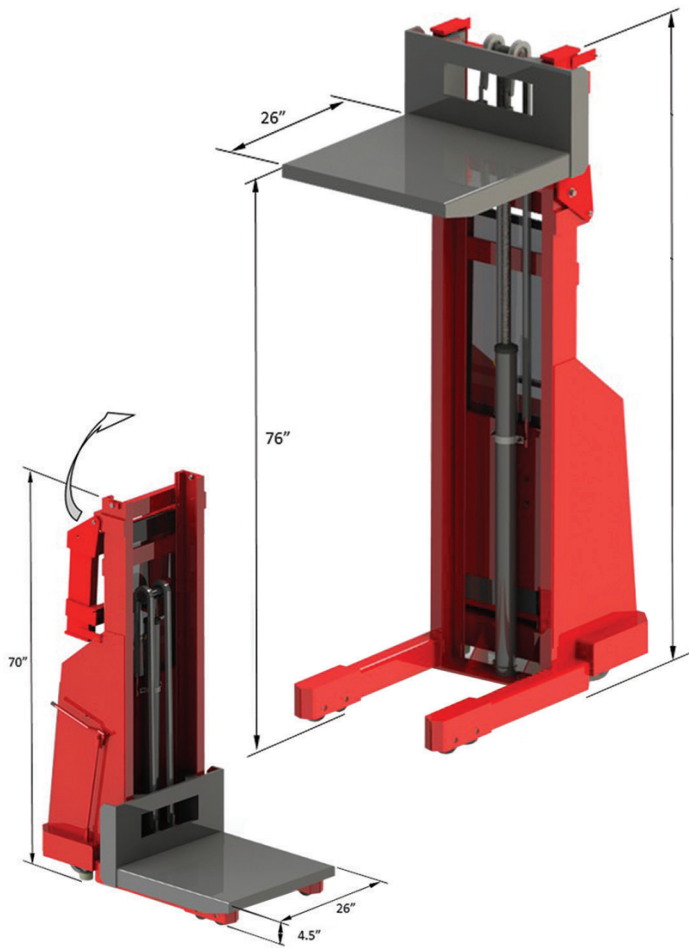
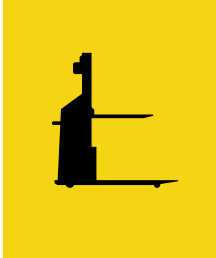

# 3000 LBS B76CFP-FM FOLDING MAST

## Features

- Formed Channel Steel Construction
- On Dash Lift/Lower Lever
- Reinforced Fixed Platform
- Fold-Down Mast; allows for stacker to travel through lower doors/openings
- Small Footprint
- Rebuildable Lift Cylinder for Easy Seals/Wiper Replacement
- Steel Safety Screen
- Fixed Legs
- Hand Controlled Floor-Lock Brake
- High-Quality Powder Coat Paint Finish

## Specifications

Capacity (lbs):	3,000
Lowered Platform Height:	4.5"
Raised Platform Height:	76"
Mast Height (Max.):	88" (folding down to 70")
Overall Length:	46"
Overall Width:	26.5"
Platform Size:	26" x 26"
Swivel Casters (Phenolic):	6" x 2"
Load Rollers (Tandem):	4" x 2"
Battery (V/Ah):	12 / 125
Charger (V/A):	12 / 10

For custom colour options, please contact Mobile direct @ 1 800 527 4612

## B76CFP-FM FOLDING MAST STACKER

The Mobile B76CFP-FM is a compact, durable and simple to operate unit. The mast is able to fold back, giving the operator more clearance to go through shorter doors or under low clearances, while then still being able to reach higher lift heights.

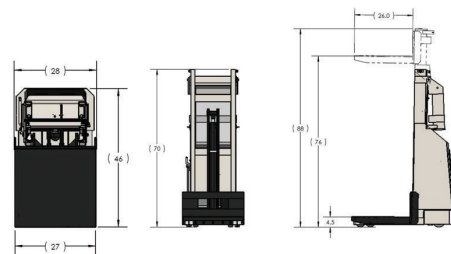

SKU: B76CFP-FM



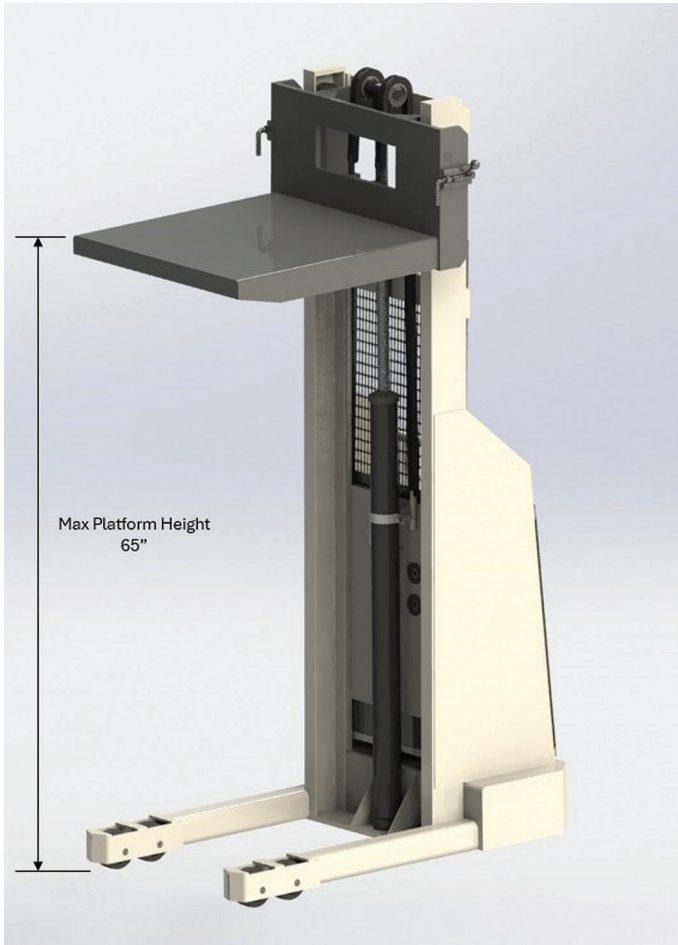
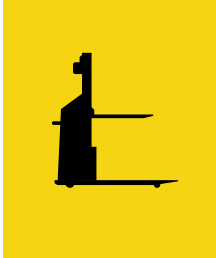

**3000 LBS**

# B65CFP-FMB

## FIXED MAST W/BASKET

### Features

- Fixed Mast
- Stacker Door with vertical hinge to ensure against lost doors in the field
- Custom designed basket to provide extended platform height
- Custom "Retention Lock" to ensure the basket held in place

### Specifications

Capacity (lbs):	3,000
Lowered Platform Height:	4.5"
Raised Platform Height:	65"
Mast Height (Max.):	76"
Platform Size:	26" x 26"
Swivel Casters (Phenolic):	6" x 2"
Load Rollers (Tandem):	4" x 2"
Battery (V/Ah):	12 / 125
Charger (V/A):	12 / 10

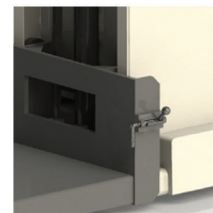
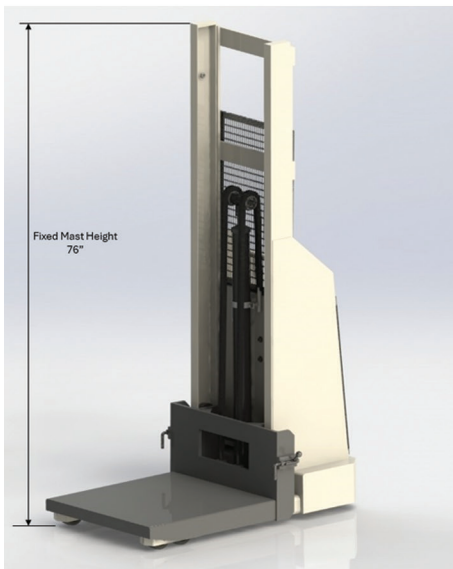

Basket Retention Latches

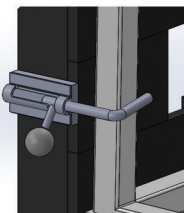

Basket Retention Latches



Capped Masts

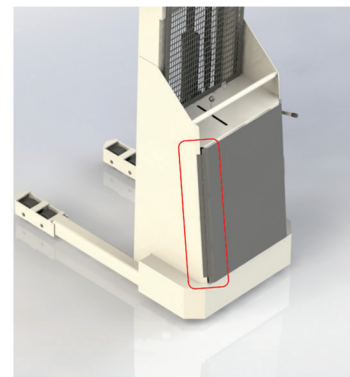

Hinged Access Door

### B65CFP-FMB FIXED MAST W/BASKET STACKER

Mobile B65CFP-FMB is a compact, durable and simple to operate unit. Fixed Mast for enhanced sturdiness with Custom Retention Lock.

SKU: B65CFP-FMB

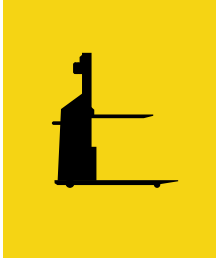

\*Model shown with Adjustable Straddle Legs

### FTAF173 FIXED STRADDLE LEGS STACKER

The Mobile FTAF173 Fixed Straddle Legs Stacker is perfectly suited for high reach, tight space applications. Equipped with power lift and easy to maneuver manual push/pull, the FTAF173 is designed to lift a variety of loads, is perfect for racking and shelving applications as well as loading/unloading trucks where docks do not exist.

# 1000 LBS FTAF173 FIXED STRADDLE LEGS

#### Features

- Formed Channel Steel Construction
- Adjustable Forks/Straddle Legs
- 6:1 Safety Factor Ensuring Safe Fork Lowering
- Steel Safety Screen
- 5th Wheel with Grease Nipple
- 90° Degree 36" Forks
- Fixed Straddle Legs
- Single Load Wheel w/uncapped wheel well for easy access
- On Dash Lift/Lower Lever
- Rebuildable Lift Cylinder for Easy Seals/Wiper Replacement
- Hand Controlled Floor-Lock Brake
- High-Quality Powder Coat Paint Finish
- North American Designed

#### Specifications

Capacity (lbs):	1,000
Lowered Fork Height:	3"
Raised Fork Height (Max):	173"
Custom Fork Size:	36"
Steer Wheels:	7" Polyurethane
Load Rollers:	4" Phenolic
Battery (V/Ah):	12 / 125 Heavy Duty
Charger (V/A):	12 / 10 (w/Overload Protect)

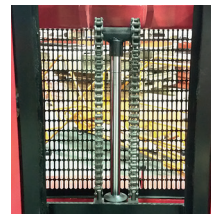

Lift Cylinder



5th Wheel Steering

SKU: FTAF173

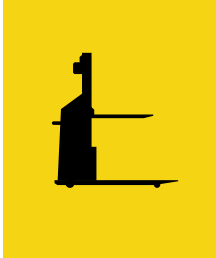

# 500 LBS OBST500 ON-BOARD TOTE



## OBST500 ON-BOARD TOTE STACKER

Mobile's OBST500 On-Board Hydraulic Tote Stackers provide users with a safe and efficient means of lifting and stacking plastic totes directly within a truck. Each Tote Stacker is equipped with a wired remote control for easy use of operation and can be installed in most truck bodies with minimal effort.

### Features

- Heavy Duty Steel Construction
- Rugged Plastic Fingers
- Remote Control
- Easy Installation into Truck
- Hardwired Directly to Truck Battery
- Supplied w/Bolt Holes & Lugs for floor installation
- North American Designed

### Specifications

Capacity (lbs):	500
Minimum Height:	32 7/8"
Maximum Height:	83"
Mast Height:	80 15/16"
Carriage Arm Width:	42 3/8"
Overall Width:	20"
Overall Length:	20"
Weight (lbs):	420

\*\*\* Designed for Medical Waste Bins \*\*\*



Raised Position



Installed

SKU: OBST500



# SELF-PROPELLED

Semi-Electric <b>ESET26P</b>	68-69	Low Lift Fork-Over <b>LLS26FFNU</b>	90-91
Full Electric <b>EFET33N</b>	70-71	Walkie Long Handle <b>APSWLH-SL</b>	92-93
Full Electric Lithium Powered <b>EFET33N-LB</b>	72-73	Heavy Duty <b>APSPFN SERIES</b>	94-95
Full Electric Lithium Powered <b>EFET44N-LB</b>	74-75	Dual Lifting <b>APS35DFFN</b>	96-97
Electric Scale <b>EFET33N-LB-SC</b>	76-77	Counter Balance <b>CBS28N</b>	98-99
Weigh Scale <b>EFET33SC</b>	78-79	Counter Balance <b>CBSN SERIES</b>	100-101
Ride-On <b>ESPT44-55RN</b>	80-81	Stand-Up Reach <b>RT33SP</b>	102-105
Long Handle <b>ESPT44WLH</b>	82-83	<b>/ RT33DP / RT44SP</b>	
Heavy Duty <b>HESPTN</b>	84-85	Power Tug <b>TUG22EN</b>	106-107
Low Lift Electric <b>ESPT44-LL</b>	86-87	Power Tug <b>TUG15</b>	108
Low Lift Straddle <b>LLS26NU</b>	88-89	Motorized Platform Cart <b>MPC</b>	109



**SEMI-ELECTRIC / FULL ELECTRIC / LONG HANDLE / RIDE-ON / / WEIGH SCALE / HEAVY DUTY PALLET TRUCKS  
LOW-LIFT / ALL-PURPOSE / LONG HANDLE / HEAVY DUTY / RIDE-ON / COUNTER BALANCE / REACH STACKERS  
TUG MOTORS / PLATFORM CARTS**



# 2645 LBS ESET26P SEMI-ELECTRIC (LITHIUM-ION)

## Features

- Fast Manual Pump
- Ergonomic Handle
- Electronic Traction Control
- Non-Marking Wheels
- Light-Weight, Quick-Change Lithium-Ion Battery
- Free Wheel Mode
- Compact and Light (where space and weight are critical)

## Specifications

Capacity (lbs):	2,645
Fork Dimensions:	20.6" x 48" • 27" x 48"
Wheels:	Rubber/Poly
Overall Length:	61"
Lift Height:	4.5"
Lowered Height:	3"
Drive Motor:	2 x .25KW
Battery Type:	Lithium-Ion
Battery Weight (lbs):	3.3
Brake:	Electric
Grade Rating:	5%
Sound Level:	60db
Turning Radius:	54"
Battery (VAh):	36 / 12.8
Battery Charger (VA):	42 / 3 UL Listed (CSA Certified)
Dual Traction Steer Wheel:	7.88" (200mm)
Tread:	6.3" (160mm)

## ESET26P SEMI-ELECTRIC PALLET TRUCK (LITHIUM-ION)

ESET26P is ideal for many workplace applications. It is a compact, electric assisted, dual-drive pallet truck that can be used in most manual jack applications. The ESET26P is a powerful, stable and quiet machine with a lightweight quick change Li-Ion battery enabling continuous use. The first pallet truck with two traction/steering wheels in the market. The big diameter (200mm) and tread (160mm) provide great stability without the need for stabilizers. Non-marking rubber affords great traction and comfortable usage on all applications.

SKU: 20.6" x 48" (170222-P), 27" x 48" (170223-P)



**QUICK CHARGE:** The ESET26P offers a Li-Ion Battery that is light and easy to remove for quick recharging and offers continuous operation with a spare battery.



**POWERFUL:** Thanks to the ESET26P's high torque and the dual drive system, loads up to 2,650 lbs can be moved easily.



**SPEED/CONTROL:** The ESET26P has efficient and reliable dual drive system which increases traction and usability with variable speed and control options.



**OVERALL VALUE:** The ESET26P features a durable design with robust components to ensure low maintenance costs.



**ESET26P SEMI-ELECTRIC LITHIUM-ION POWERED PALLET TRUCK**

**SPECIFICATIONS • PERFORMANCE**

Model		ESET26P-B (BASIC)	ESET26P-P (PLUS)
Drive	lbs	Electric	
Operator Type	lbs	Pedestrian	
Load Capacity	(Q) kg	1200	1200
Load Center Distance	(C) mm	600	600
Load Distance (center of drive axle to load wheel)	(X) mm	932	932
Wheelbase	(Y) mm	1192	1192
Service Weight	kg	86 - 88	86 - 88
Axle Loading (Laden Front / Rear)	kg	395 / 889 - 891	395 / 889 - 891
Axle Loading (Un-laden Front / Rear)	kg	59 / 25 - 27	59 / 25 - 27
Tires (Front / Rear)		G / P	G / P
Tire Size, Front (Ø x width)		200 x 40	200 x 40
Tire Size, Rear (Ø x width)		82 x 82 - 60	82 x 82 - 60
Side Wheels (Ø x width)		-	-
Wheels, Number (x=driven wheels) Front / Rear		2 x / 2-2x / 4	2 x / 2-2x / 4
Tread, Front	(b10) mm	162	162
Tread, Rear (Min/Max****)	(b11) mm	375	375
Lift Height	(h3) mm	115	115
Height of Tiller in Drive Position (Min / Max****)	(h14) mm	710 / 1185	710 / 1185
Height, Lowered	(h13) mm	85	85
Overall Length	(l1) mm	1600	1600
Length to Face of Forks	(l2) mm	450	450
Overall Width (Front / Rear - Min / Max****)	(b1) mm	525	525
Fork Dimensions	(s/e/l) mm	55 / 150 / 1150	55 / 150 / 1150
Distance Between Fork Arms (Min / Max****)	(b5) mm	525	525
Ground Clearance (Center of Wheel Base)	(m2) mm	30	30
Aisle Width (for pallets 800 x 1200 lengthways)	(Ast) mm	2063	2063
Turning Radius	(Wa) mm	1382	1382
Travel Speed (Laden / Un-laden)	Km/h	4.2 / 5.3	4.2 / 5.3
Lifting Speed (Laden / Un-laden**)		12 / 12	12 / 12
Lowering Speed (Laden / Un-laden)	m/s	.1 / .02	.1 / .02
Max Gradeability (Laden / Un-laden)	%	5 / 10	5 / 10
Service Brake		Electric	Electric
Drive Motor Power	kW	2 x .25	2 x .25
Lift Motor Power	kW	-	-
Battery Voltage / Nominal Capacity C5	V/Ah	36 / 10.4	36 / 12.6
Battery Weight	kg	3	3
Energy Consumption ACC. To EN 16796-1 Cycle	kWh/h	-	-
Sound Level At Driver's Ear	db(A)	60	60

\*G = Rubber, P = Polyurethane, N = Nylon

\*Because of continual product improvements, specifications may be subject to change without notice

\*\*12 / 5AV

\*\*\*Part#: 170222-P (20.6" x 48") | Part#: 170223-P (27" x 48")

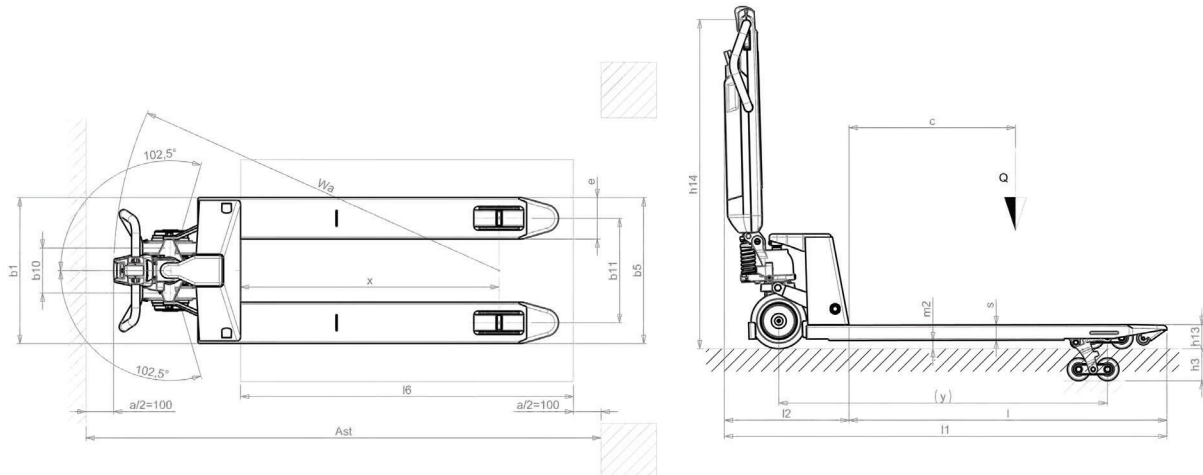



# 3300 LBS EFET33N FULL-ELECTRIC



## EFET33N FULL-ELECTRIC PALLET TRUCK

EFET33N is a full-electric pallet truck designed as an economic alternative to more expensive fully electric models. These units feature powered operation for lifting, and self-propelled movement for easy transporting of goods. The compact and light design is suitable for a variety of light-duty applications in warehouses or similar environments. The EFET33N features a built-in charger for increased mobility and operating range, along with a battery discharge indicator that automatically cuts off the lift function when not in use.

### Features

- Full Electric Drive and Lift
- Built-In Charger
- Battery Discharge Indicator
- Automatic Lift Cut-Off for higher battery lifetime
- Suspension Casters for better performance with obstacles, stability, and less noise

### Specifications

Capacity (lbs):	3,300
Fork Length:	48" ( <sup>1</sup> 31.5" / <sup>1</sup> 39.3" )
Overall Fork Width:	21.3" / 27"
Raised Fork Height:	7.6"
Lowered Height:	3.1"
Fork Width:	6.3"
Drive Wheels:	8.7" x 2.8"
Load Rollers Single:	3.1" x 3.7"
Aisle Width:	87.8"
Turning Radius:	61.2"
Travel Speed - Laden/Un-Laden (mph):	2.6 / 2.9
Lifting Speed - Laden/Un-Laden (ft/m):	5.9 / 10.4
Max Gradient - Laden/Un-Laden (%):	4 / 10
Battery Voltage (V/Ah):	(x2) 12 / 64
Weight (lbs):	440

<sup>1</sup>Available as special order



Pump Assembly



Console

SKU: EFET33N



**CAP** 3,300 LBS

**EFET33N FULL-ELECTRIC PALLET TRUCK**

**SPECIFICATIONS • PERFORMANCE**

Model		EFET33N
Capacity	lbs	3300
Weight	lbs	440
Load Center	(C) in	23.6
Wheelbase	(Y) in	53.9
Lowered Fork Height	(h13) in	3.1
Raised Fork Height	(h1) in	7.6
Steer Wheel	in	8.7 x 2.8
Fork Size	(e) in	6.3
Overall Fork Width	(b5) in	21.3 / 27
Fork Length	(l) in	48 (31.5" & 39.3" also available)
Load Roller	in	3.1 x 3.7
Turning Radius	(Wa) in	61.2
Aisle Width (for pallets: 32" x 48")	in	87.8
Travel Speed (Laden / Un-laden)	mph	2.6 / 2.9
Lift Speed (Laden / Un-laden)	ft/m	5.9 / 10.4
Max. Gradeability (Laden / Un-laden)	%	4 / 10
Battery Voltage	V/Ah	(x2) 12 / 64
Battery acc. to DIN 43531/35/36 A, B, C no		No
Battery Compartment Size	in	(x2) 10.4 x 7.5 x 8.5
Battery Size	in	(x2) 10.2 x 6.8 x 8.5

\*Because of continual product improvements, specifications may be subject to change without notice

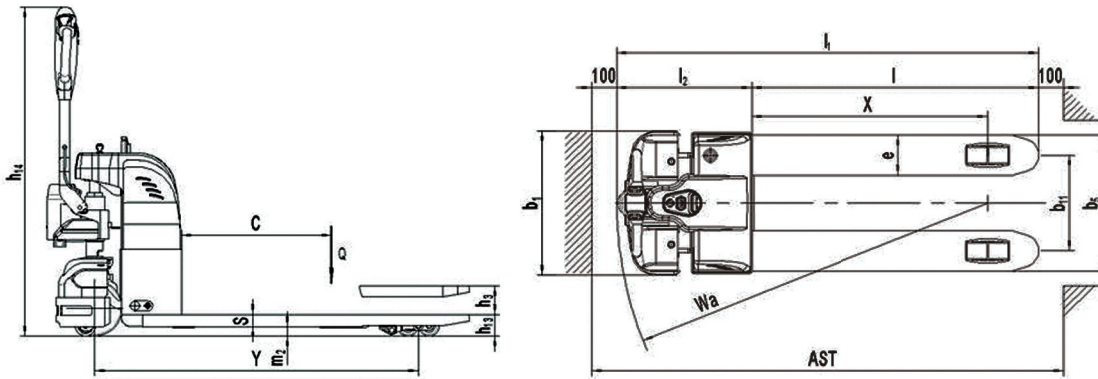

\*Container Order Available: 20ft Container = 18 pieces | 40ft Container = 38 pieces



Battery Compartment



# 3300 LBS EFET33N-LB LITHIUM POWERED

**Features**

- Full Electric Drive and Lifting/Lowering
- Maintenance-Free Smart (light-weight) Lithium Battery
- Integrated PIN Code Display for Smart Control and Operation
- Automatic Speed Reduction at Various Tiller Angles
- Turtle Speed Option
- Active (upright) Tiller, suitable for confined spaces
- Battery Discharge Indicator
- Hour Meter
- On-Board Diagnostics via Error Codes
- Dual Butterfly-Style Thumb Driving Controls
- Reinforced Fork Frame
- Suitable for Operation on Loading Docks
- Supporting Wheels
- Maintenance Friendly
- Curtis Controller and CAN-bus technology

**Specifications**

Capacity (lbs):	3,300
Fork Length:	45.3"
Overall Fork Width:	21.3" / 27"
Lift Height:	4.53"
Lowered Height:	3.15"
Fork Width:	6.3"
Drive Wheel:	8.27" x 2.76"
Battery (V/Ah):	24 / 36
Working Hours (per charge):	4.5
Charge (Discharge Cycles):	800
Weight (lbs):	217 / 278

**EFET33N-LB FULL-ELECTRIC (LITHIUM POWERED) PALLET TRUCK**

The new "LITHIUM POWERED" full electric pallet truck model EFET33N-LB recently added to the Mobile Self-Propelled range comes with a capacity of 3300 lbs. Ideal for confined spaces with a turning radius of 52". Integrated PIN code panel with LCD Display. Smart handle design can be operated with handle in the upright position. Ideal for light to medium duty applications. Maintenance friendly.

1500kg

Small Size

123kg

Low self-weight

Li

Lithium battery

Smart design

CAN-bus

Best Cost Performance Ratio

CE

SKU: EFET33N-LB (21"W), EFET33N-LB (27"W)



<b>EFET33N-LB FULL-ELECTRIC (LITHIUM POWERED) PALLET TRUCK</b>			
Model		<b>EFET33N-LB (21"W)</b>	<b>EFET33N-LB (27"W)</b>
Capacity	(Q) lbs	3300	
Drive		Battery	
Operator Type		Pedestrian	
Load Center Distance	(C) in	23.6	
Load Distance (center of drive axle to fork)	(X) in	37.3	
Wheelbase	(Y) in	46.6	
Service Weight	lbs	271	278
Axle Loading (Laden Front / Rear)	lbs	1370.6 / 2200	1377 / 2200
Axle Loading (Un-laden Front / Rear)	lbs	211 / 60	218 / 60
Tires		Polyurethane (PU)	
Tire Size, Front (Ø x width)	in	8.27 x 2.76	
Tire Size, Rear (Ø x width)	in	3.15 x 3.66 (3.15 x 2.76)	
Additional Wheels Dimensions (Ø x width)	in	-/ 3.15 x 1.18	
Wheels, Number (x=driven wheels) Front / Rear		1 x / 2(1x/ 4) or 1 x +2/ 2(1x+2/ 4)	
Tread (Front)	(b10) in	-/16.93	
Tread (Rear)	(b11) in	14.96	20.67
Lift Height	(h3) in	4.53	
Height of Tiller in Drive Position (Min / Max)	(h14) in	27.6 / 45.7	
Height, Lowered	(h13) in	3.15	
Overall Length	(l1) in	60.24	
Length to Face of Forks	(l2) in	14.96	
Overall Width	(b1) in	21.3	27
Fork Dimensions	(s/e/l) in	1.85 / 6.3 / 45.3	
Width Across Forks	(b5) in	21.3	27
Ground Clearance (Center of Wheelbase)	(m2) in	1.3	
Aisle Width (for pallets 31.5 x 47.25 lengthways / 7.88 safe distance)	(Ast) in	78.74	
Turning Radius	(Wa) in	52.37	
Travel Speed (Laden/Un-laden)	mph	2.85 / 2.98	
Lift Speed (Laden / Un-laden)	fps	.065 / .082	
Lowering Speed (Laden / Un-laden)	fps	.164 / .131	
Max Gradeability (Laden / Un-laden)	%	6 / 16	
Service Brake		Electromagnetic	
Drive Motor Rating S2 60min	HP (metric)	.883	
Lift Motor Rating at S3 10%	HP (metric)	.910	
Battery acc. to DIN 43531/35/36 A, B, C, no		/	
Battery Voltage / Nominal Capacity K5	V/Ah	24 / 20 (24 / 30; 24 / 36)	
Battery Weight	lbs	10	
Energy Consumption acc. to VDI cycle	kWh/h	.22	
Type of Drive Control		DC Speed Control	
Sound Level (at driver's ear acc. to EN 12053)	dB(A)	<70	

\*Because of continual product improvements, specifications may be subject to change without notice

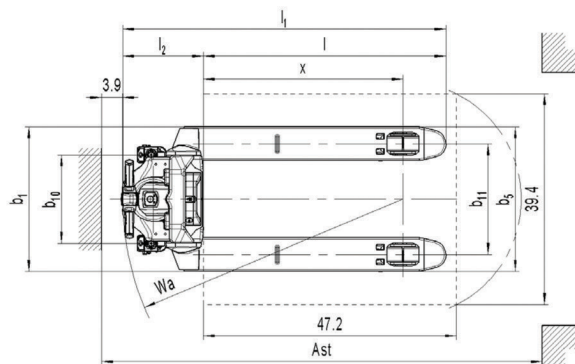
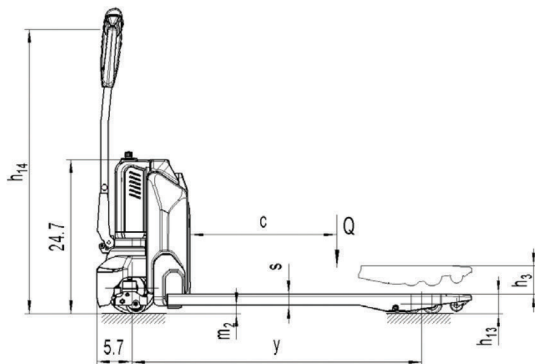



Battery Compartment



# 4400 LBS EFET44N-LB LITHIUM POWERED

## Features

- Full Electric Drive and Lifting/Lowering
- Maintenance-Free Smart (light-weight) Lithium Battery
- Integrated PIN Code Display for Smart Control and Operation
- Automatic Speed Reduction at Various Tiller Angles
- Turtle Speed Option
- Active (upright) Tiller, suitable for confined spaces
- Battery Discharge Indicator
- Hour Meter
- On-Board Diagnostics via Error Codes
- Dual Butterfly-Style Thumb Driving Controls
- Reinforced Fork Frame
- Suitable for Operation on Loading Docks
- Supporting Wheels
- Maintenance Friendly
- Curtis Controller and CAN-bus technology

## Specifications

Capacity (lbs):	4,400
Fork Length:	45.28" (1150mm)
Overall Fork Width:	21.26" / 27" (540mm / 685mm)
Lift Height:	4.53"
Lowered Height:	3.15"
Fork Width:	6.3"
Drive Wheel:	8.27" x 2.76"
Battery (V/Ah):	48 / 20
Charger (V/A):	48 / 9
Working Hours (per charge):	4.5
Charge (Discharge Cycles):	800
Weight (lbs):	328 / 337

## EFET44N-LB FULL-ELECTRIC (LITHIUM POWERED) PALLET TRUCK

The new "LITHIUM POWERED" full electric pallet truck model EFET44N-LB recently added to the Mobile Self-Propelled range comes with a capacity of 4400 lbs. Ideal for confined spaces with a turning radius of 52". Integrated PIN code panel with LCD Display. Smart handle design can be operated with handle in the upright position. Ideal for light to medium duty applications. Maintenance friendly.



SKU: EFET44N-LB (21"W), EFET44N-LB (27"W)

## FRONT VIEW



## BACK VIEW



<b>EFET44N-LB FULL-ELECTRIC (LITHIUM POWERED) PALLET TRUCK</b>			
Model		<b>EFET44N-LB (21"W)</b>	<b>EFET44N-LB (27"W)</b>
Capacity	(Q) lbs	4400	
Drive		Battery	
Operator Type		Pedestrian	
Load Center Distance	(C) in	23.63	
Load Distance (center of drive axle to fork)	(X) in	37.44	
Wheelbase	(Y) in	46.82	
Service Weight	lbs	328	337
Axle Loading (Laden Front / Rear)	lbs	1366 / 3362	1375 / 3362
Axle Loading (Un-laden Front / Rear)	lbs	253 / 75	262 / 75
Tires		Polyurethane (PU)	
Tire Size, Front (Ø x width)	in	8.27 x 2.76	
Tire Size, Rear (Ø x width)	in	3.15 x 3.66 (3.15 x 2.76)	
Additional Wheels Dimensions (Ø x width)	in	-/ 3.15 x 1.19	
Wheels, Number (x=driven wheels) Front / Rear		1 x / 2(1x/ 4) or 1 x +2/ 2(1x+2/ 4)	
Tread (Front)	(b10) in	-/16.93	
Tread (Rear)	(b11) in	14.96	20.67
Lift Height	(h3) in	4.53	
Height of Tiller in Drive Position (Min / Max)	(h14) in	27.6 / 45.7	
Height, Lowered	(h13) in	3.15	
Overall Length	(l1) in	60.48	
Length to Face of Forks	(l2) in	15.2	
Overall Width	(b1) in	21.26	26.97
Fork Dimensions	(s/e/l) in	1.85 / 6.3 / 45.3	
Width Across Forks	(b5) in	21.26	26.97
Ground Clearance (Center of Wheelbase)	(m2) in	1.3	
Aisle Width (for pallets 31.5 x 47.25 lengthways / 7.88 safe distance)	(Ast) in	78.98	
Turning Radius	(Wa) in	52.6	
Travel Speed (Laden/Un-laden)	mph	2.98 / 3.23	
Lift Speed (Laden / Un-laden)	fps	.055 / .072	
Lowering Speed (Laden / Un-laden)	fps	.164 / .098	
Max Gradeability (Laden / Un-laden)	%	7 / 16	
Service Brake		Electromagnetic	
Drive Motor Rating S2 60min	HP (metric)	1.019	
Lift Motor Rating at S3 10%	HP (metric)	1.087	
Battery acc. to DIN 43531/35/36 A, B, C, no		/	
Battery Voltage / Nominal Capacity K5	V/Ah	48 / 20	
Battery Weight	lbs	16.5	
Energy Consumption acc. to VDI cycle	kWh/h	.18	
Type of Drive Control		DC Speed Control	
Sound Level (at driver's ear acc. to EN 12053)	dB(A)	<70	

\*Because of continual product improvements, specifications may be subject to change without notice

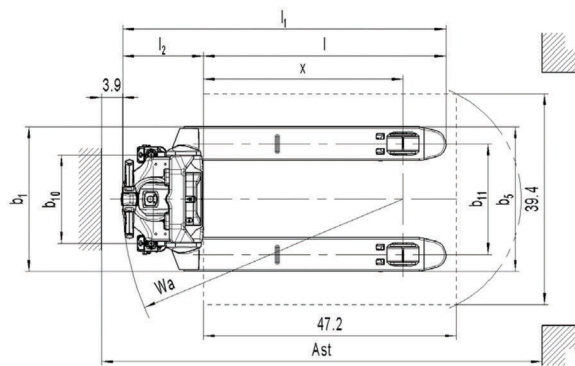
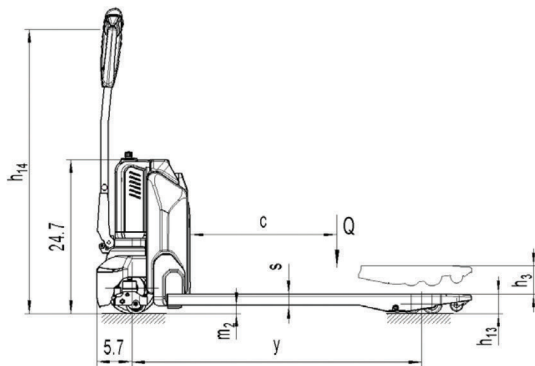



### EFET33N-LB-SC ELECTRIC SCALE W/THERMAL PRINTER INSTALLED

EFET33N-LB-SC lithium powered pallet truck with scale combines material handling and weighing intelligently, improving work place efficiency. The model adopts 650W drive unit and high precision weighing system to improve handling of goods. Suitable for supermarkets and logistic centers. Driving with handle in vertical position, fast charging Li-Ion battery, and high precision weighing display with Printer option.



SKU: EFET33N-LB-SC (22"), EFET33N-LB-SC (27")

**3300 LBS**

# EFET33N-LB-SC

**ELECTRIC SCALE W/THERMAL PRINTER**

#### Features

- Drive Motor with intelligent Curtis Controller, CAN-bus technology
- Integrated PIN Code Panel with LCD display for smart control and operation
- Cumulative Function
- Unit switch between LBS / KG
- Multiple function keys
- High precision sensor (3kg Accuracy)
- Thermal Printer with low voltage protection function
- Weighing Terminal with built-in (4.5 Ah) rechargeable battery - fully charged life 3-6 months
- Tiller supported with air spring
- Speed reduction at different angles with active Tiller function in the upright position
- Strong Steel Apron protects operator feet
- Ability to overcome ramps (suitable for loading docks)

#### Specifications

Capacity (lbs):	3,300
Fork Length:	45"
Overall Fork Width:	22" / 27.8"
Overall Length:	61.42"
Overall Width:	22" / 27.8"
Lowered Height:	3.46"
Turning Radius:	54.61"
Battery - Lithium-Ion (V/Ah):	24 / 20-36 (Maintenance-Free)
Charge:	100% (min 2.5 hours)
Weight (lbs):	397 / 408

#### Options: Thermal Printer



Scale



Charging



Thermal Printer (Optional)



CURTIS Controller

EFET33N-LB-SC ELECTRIC SCALE PALLET TRUCK		EFET33N-LB-SC	
Model		EFET33N-LB-SC	
Power		Battery	
Operator Type		Pedestrian	
Load Capacity	(Q) lbs	3300	
Load Center Distance	(C) in	23.6	
Load Distance (center of drive axle to fork)	(X) in	36.54	
Wheelbase	(Y) in	46.57	
Service Weight	lbs	397	408
Axle Loading (Laden Front / Rear)	lbs	1040 / 2663	1049 / 2665
Axle Loading (Un-laden Front / Rear)	lbs	267 / 130	267 / 141
Tires		Polyurethane (PU)	
Tire Size, Front (Ø x width)	in	8.27 x 2.76	
Tire Size, Rear (Ø x width)	in	3.15 x 3.66 (3.15 x 3.76)	
Additional Wheels Dimensions (Ø x width)	in	-/ 3.15 x 1.18	
Wheels, Number (x=driven wheels) Front / Rear		1 x / 2(1x/ 4) or 1 x +2/ 2(1x+2/ 4)	
Tread (Front)	(b10) in	-/16.93	
Tread (Rear)	(b11) in	14.96	20.67
Lift Height	(h3) in	4.53	
Height of Tiller in Drive Position (Min / Max)	(h14) in	29.13 / 45.75	
Height, Lowered	(h13) in	3.46	
Overall Length	(l1) in	61.42	
Length to Face of Forks	(l2) in	16.14	
Overall Width	(b1) in	22.13	27.83
Fork Dimensions DIN ISO 2331	(s/e/l) in	2.52 / 7.17 / 45.28	
Width Across Forks	(b5) in	22.13	27.83
Ground Clearance (Center of Wheelbase)	(m2) in	.83	
Aisle Width (predetermined load dimensions)	(Ast) in	78.74	
Turning Radius	(Wa) in	54.61	
Travel Speed (Laden/Un-laden)	mph	2.61 / 2.73	
Lift Speed (Laden / Un-laden)	fpm	2.95 / 4.33	
Lowering Speed (Laden / Un-laden)	fpm	9.84 / 7.87	
Max Gradeability (Laden / Un-laden)	%	6 / 16	
Service Brake		Electromagnetic	
Drive Motor Rating S2 60min	HP	.87	
Lift Motor Rating at S3 10%	HP	.67	
Battery acc. to DIN 43531/35/36 A, B, C, no		No	
Battery Voltage / Nominal Capacity K5	V/Ah	24 / 20 (24 / 30; 24 / 36)	
Battery Weight	lbs	10	
Energy Consumption acc. to DIN EN 16796	kWh/h	.19	
Type of Drive Control		DC Speed Control	
Sound Level (at driver's ear acc. to EN 12053)	dB(A)	<70	

\*Because of continual product improvements, specifications may be subject to change without notice

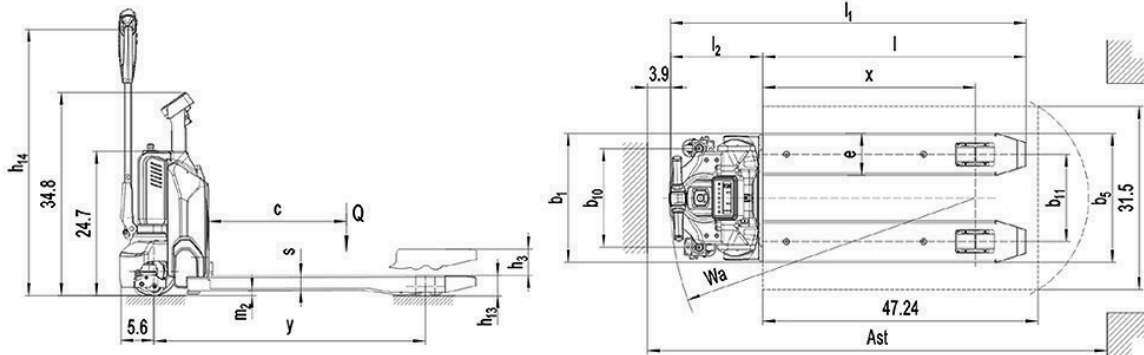



# 3300 LBS EFET33SC WEIGH SCALE



## ECO EFET33SC FULL-ELECTRIC WEIGH SCALE PALLET TRUCK

ECO EFET33SC is a full-electric pallet truck designed as an economic alternative to more expensive fully electric models that also features a built-in Weigh Scale. These units feature powered operation for lifting and lowering loads, and self-propelled movement for easy transporting of goods. The easy to read meter features a high-contrast LCD display for better visibility, and “click-able” keypad. The compact and light design is suitable for a variety of light-duty applications in warehouses or similar locations. The EFET33SC features a built in charger for increased mobility and operating range, along with a battery discharge indicator that automatically cuts off the lift function when not in use.

### Features

- Weigh Scale Functionality
- Tolerance :+/-0.4% of the truck's rated capacity of 3,300lbs
- Graduation in 2.2 and 4.4lbs (1 and 2kg) steps
- Scale functions: zero correction, gross/net weighing, total weight
- Low battery warning + auto shut off function after 3 minutes
- (4) 1.5V AA batteries
- Full Electric Drive and Lift
- Built-In Charger
- Battery Discharge Indicator
- Automatic lift cut-off for higher battery lifetime
- Suspension casters for better performance with obstacles, stability, and less noise

### Specifications

Capacity (lbs):	3,300
Fork Length:	45"
Overall Fork Width:	22.6"
Raised Fork Height:	8.07"
Lowered Height:	3.5"
Fork Width:	7"
Drive Wheels:	7.8" x 2.75"
Load Rollers:	3.15" x 2.75"
Turning Radius:	57.87"
Travel Speed - Laden/Un-Laden (mph):	2.6 / 2.85
Battery Voltage (V/Ah):	(x2) 12 / 64
Weight (lbs):	517



LCD Display Buttons

SKU: EFET33SC





**EFET33SC FULL-ELECTRIC WEIGH SCALE PALLET TRUCK**

**SPECIFICATIONS • PERFORMANCE**

Model		EFET33SC
Capacity	(Q) lbs	3300
Load Center	(c) lbs	23.6
Load Distance (center of drive axle to fork)	(x) in	37.2
Wheelbase	(y) in	50.9
Weight	lbs	517
Axle Loading (Laden Front / Rear )	lbs	1133 / 2684
Axle Loading (Un-laden Front / Rear)	lbs	374 / 143
Steer Wheel		Polyurethane (PU)
Steer Wheel Size	(x w) in	7.8 x 2.75
Load Roller Size	(x w) in	3.15 x 2.75
Additional Wheels (dimensions)	(x w) in	3.15 x 1.18
Wheels, number front/rear (x=driven wheels)		1x+2/4
Tread (Steer Wheel)	(b10) in	16.1
Tread (Load Roller)	(b11) in	14.9
Raised Fork Height	(h3) in	8.07
Height of Handle in drive position (Min / Max)	(h14) in	31.5 / 46
Lowered Fork Height	(h13) in	3.5
Overall Length	(l1) in	65.9
Length to Face of Forks	(l2) in	20
Overall Width	(b1) in	22.6
Fork Dimensions	(s/e/l) in	2.2 / 7 / 45
Distance Between Forks	(b2) in	22
Ground Clearance (Center of Wheelbase)	(m2) in	.9
Aisle Width for Pallets (800 x 1200 lengthways)	(AST) in	76.7
Turning Radius	(Wa) in	57.87
Travel Speed (Laden / Un-laden)	mph	2.6 / 2.85
Lift Speed (Laden / Un-laden)	ft/s	.098 / .173
Lowering Speed (Laden / Un-laden)	ft/s	.16 / .118
Max. Gradeability (Laden / Un-laden)	%	4 / 10
Service Brake		Electromagnetic
Drive Motor Rating S2 60min	kW	.45
Lift Motor Rating at S3 10%	kW	.8
Energy Consumption acc. to VDI cycle	kWh/h	.39
Type of Drive Control		DC speed Control
Sound level at driver's ear acc. to EN 12053	(A) dB	69
Battery Voltage, nominal capacity K5	V / Ah	(x2) 12 / 64
Battery Weight	lbs	105.6
Battery acc. to DIN 43531/35/36 A, B, C no		No
Battery Compartment Size	in	(x2) 10.4 x 7.5 x 8.5
Battery Size	in	(x2) 10.2 x 6.8 x 8.5

\*Because of continual product improvements, specifications may be subject to change without notice

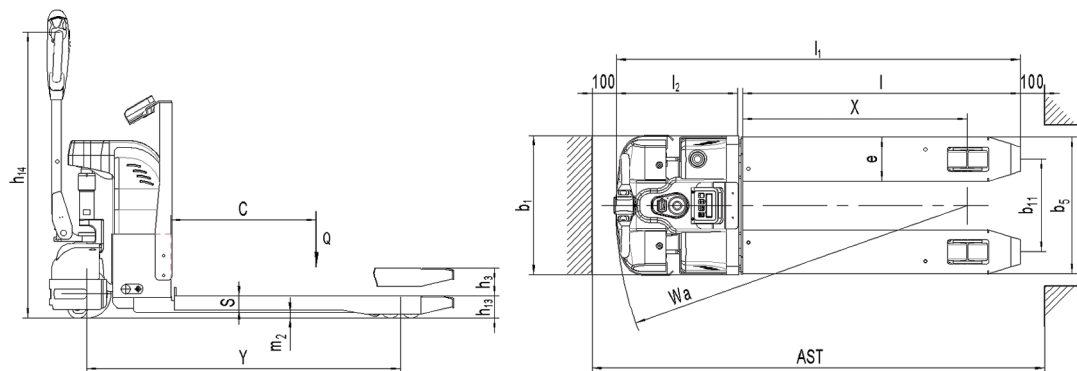

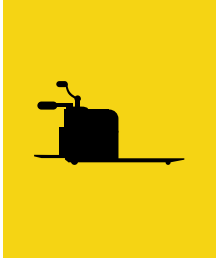

**4400/5500 LBS**

# ESPT44-55RN

**RIDE-ON**

**Features**

- Schabmueller Powerful AC Drive Motor with ZF Gearbox and Intorque Electromagnetic Brake
- Rader Vogel or Wicke Drive Wheel
- High-Performance Zapi Drive and Steering Controllers
- REMA Handle
- Guard Rails & Platform

**Specifications**

Capacity (lbs):	4,400 / 5,500
Fork Length:	48"
Overall Fork Width:	21" / 27"
Battery (V/Ah):	24 / 160 (ESPT44RN)
Battery (V/Ah):	24 / 270 (ESPT55RN)
Charger (V/A):	24 / 30
Weight (lbs):	1360 / 1694

**ESPT44-55RN SELF-PROPELLED (RIDE-ON) PALLET TRUCK**

The ESPT44RN/55RN Self-Propelled pallet truck is designed for heavy duty lifting and transporting applications. These units feature full electric lifting and self-propelled movement with the option of a "ride-on" operator platform, enabling safe and more efficient load handling, particularly in long-distance warehouse applications.

**Options: PIN-Code Panel • Electric Power Steering (EPS)  
Fork Lengths: 51"/59"/70.8"/78.7"/84" • Side Extraction Battery • Battery: 210Ah (ESPT44RN) | 350Ah (ESPT55RN)  
• Built-In 24V/30A Charger**

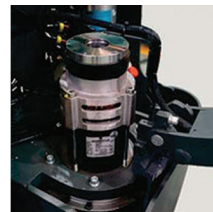

Schabmueller AC Drive Motor



PIN-Code Panel (Optional)



ZAPI Drive / Steering Controller



Electric Power Steering (EPS)

SKU: ESPT44N, ESPT44RN

ESPT44RN/ESPT55RN SELF-PROPELLED RIDE-ON PALLET TRUCK			
Model		ESPT44RN	ESPT55RN
Power		Battery	
Operator Type		Pedestrian / Stand	
Load Capacity	(Q) lbs	4400	5500
Load Center Distance	(C) in	23.6	
Load Distance (center of drive axle to fork)	(X) in	35.1 (1)	
Wheelbase	(Y) in	52.4 <sup>1(2)</sup>	56.5 <sup>1)</sup>
Service Weight	lbs	1360	1694
Axle Loading (Laden Front / Rear)	lbs	2370 / 3388	3944 / 4250
Axle Loading (Un-laden Front / Rear)	lbs	1122 / 308	1294 / 400
Tires		Polyurethane (PU)	
Tire Size, Front (Ø x width)	in	9.1 x 2.8	
Tire Size, Rear (Ø x width)	in	3.3 x 3.3	
Additional Wheels Dimensions (Ø x width)	in	3.9 x 1.6	
Wheels, Number (x=driven wheels) Front / Rear		1 x +2 / 4	
Tread (Front)	(b10) in	22.1	
Tread (Rear)	(b11) in	14.4 / 20.2	
Lift Height	(h3) in	4.7	
Height of Tiller in Drive Position (Min / Max)	(h14) in	37.4 / 53.1	
Height, Lowered	(h13) in	3.4	
Overall Length	(l1) in	70.5 <sup>2(3)</sup>	74.6
Length to Face of Forks	(l2) in	25.2 <sup>2(3)</sup>	29.3 <sup>3)</sup>
Overall Width	(b1) in	31.1	
Fork Dimensions DIN ISO 2331	(s/e/l) in	2.2 / 6.8 / 45.3	
Width Across Forks	(b5) in	21.3 / 27	
Ground Clearance (Center of Wheelbase)	(m2) in	1.2	
Aisle Width (for pallets 1000 x 2000 crossways)	(Ast) in	94.5 <sup>2(3)</sup>	98.6 <sup>3)</sup>
Aisle Width (for pallets 800 x 1200 lengthways)	(Ast) in	90.2 <sup>2(3)</sup>	94.3 <sup>3)</sup>
Turning Radius	(Wa) in	62.4	66.5 <sup>3)</sup>
Travel Speed (Laden/Un-laden)	mph	4.4 / 5	3.7 / 4.4
Lift Speed (Laden / Un-laden)	fpm	4.3 / 5.9	6.9 / 8.9
Lowering Speed (Laden / Un-laden)	fpm	6.9 / 6.9	7.9 / 7.9
Max Gradeability (Laden / Un-laden)	%	8 / 15	
Service Brake		Electromagnetic	
Drive Motor Rating S2 60min	HP	1.9	
Lift Motor Rating at S3 10%	HP	1.1	3
Battery acc. to DIN 43531/35/36 A, B, C, no		No	
Battery Voltage / Nominal Capacity K5	V/Ah	24 / 160 - 210	24 / 270 - 350
Battery Weight (minimum)	lbs	340	520
Type of Drive Control		AC Speed Control	
Sound Level (at driver's ear acc. to EN 12053)	dB(A)	69	

- 1) Load Section Lowered: +2.5in
- 2) With Side Battery Removal: +1.2in
- 3) With Compact Platform: +17.3in

\*Because of continual product improvements, specifications may be subject to change without notice

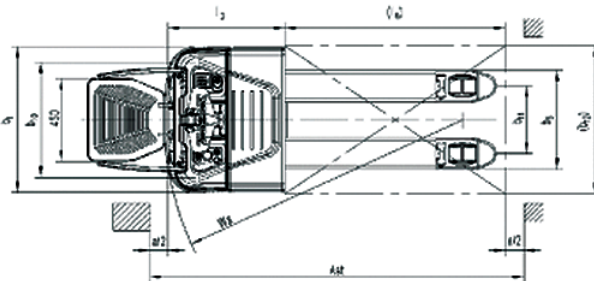
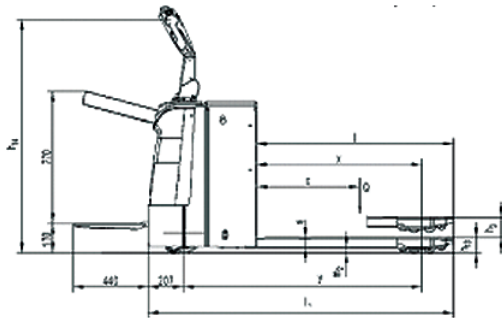



**4400 LBS**

# ESPT44WLH



**LONG HANDLE**



**Features**

- Top Quality Brand Components: Reliable multi-functional REMA tiller w/ergonomic, contact-less rocker/switches, Top quality Schabmueller AC drive motor, Kordel Gearbox, Intorq Brake,
- Wicke Drive Wheel, Zapi Controller
- CAN-bus Technology
- Long Handle design for Ergonomics and Safety
- German AC Drive Technology
- External Charger

**Specifications**

Capacity (lbs):	4,400
Fork Length:	45.2"
Overall Fork Width:	21.25" / 27"
Raised Fork Height:	8.2"
Lowered Height:	3.3"
Fork Width:	6.8"
Drive Wheels:	9" x 2.75"
Load Rollers:	3.3" x 3.3"
Turning Radius:	58.6"
Travel Speed - Laden/Un-Laden (mph):	3.54 / 3.72
Battery Voltage (V/Ah):	24 / 210
Weight (lbs):	1,177

- Compact Design
- Small Turning Radius
- Easy Maintenance
- High Performance
- Powerful Battery
- Robust Design
- High Capacity

**ECO ESPT44WLH WALKIE LONG HANDLE PALLET TRUCK**

ECO ESPT44WLH is a top choice for all-around warehousing and transportation applications, particularly where space is limited. The ESPT44WLH stands out thanks to its long handle design, which allows the operator to have a better control of the unit and operate it from safe and ergonomic heights and distance.

**Options: Load Backrest • Sideway Battery Exchange**



Battery Compartment



Drive-Train/Handle Chamber

SKU: ESPT44WLH

ESPT44WLH WALKIE LONG HANDLE PALLET TRUCK		ESPT44WLH
Model		ESPT44WLH
Capacity	(Q) lbs	4400
Load Center	(C) in	23.6
Load Distance (center of drive axle to load wheel)	(X) in	35.1
Wheelbase	(y) in	52.2
Weight (with Battery)	lbs	1177
Axle Loading (Laden Front / Rear)	lbs	1881 / 3696
Axle Loading (Unladen Front / Rear)	lbs	913 / 264
Drive Wheel (Polyurethane)	(Æ x w) in	9 dia. x 2.75
Load Rollers (Polyurethane)	(Æ x w) in	3.3 dia. x 3.3
Stabilizer Wheels (Polyurethane)	(Æ x w) in	3.9 dia. x 1.5
Tread (Front)	(b10) in	20
Tread (Rear)	(b11) in	14.4 / 20.1
Lift Height	(h3) in	4.9
Lowered Fork Height	(h13) in	3.3
Fork Dimensions	(s/e/l) in	2.3 x 6.8 x 45.2
Overall Fork Width (O.D.)	(b5) in	21.25 or 27
Handle Height (in drive position min / max)	(h14) in	33.4 / 54.5
Overall Length	(l1) in	68.3
Overall Width	(b1) in	28.7
Length (to Face of Forks)	(l2) in	23.4
Ground Clearance (Center of Wheelbase)	(m2) in	1
Turning Radius	(Wa) in	58.6
Aisle Width (for pallets: 40" x 48")	(Ast) in	76.9
Travel Speed (Laden / Un-laden)	mph	3.54 / 3.72
Lifting Speed (Laden / Un-laden)	ft/s	.072 / .098
Lowering Speed (Laden / Un-laden)	ft/s	.114 / .114
Gradeability (Laden / Un-laden)	%	8 / 15
Drive Motor Rating S2 60 min	kW	1.3
Lift Motor Rating at S3 10%	kW	.8
Energy Consumption Acc. to VDI Cycle	kWh/h	.39
Battery Voltage / Nominal Capacity K5	V/Ah	24 / 210
Battery Weight (minimum)	lbs	473
Battery acc. to DIN 43531/35/36 A,B,C, no		2Pr5
Battery Compartment Size	in	25 x 8.5 x 24.6
Battery Size	in	24.5 x 8.3 x 24.6

\*Because of continual product improvements, specifications may be subject to change without notice

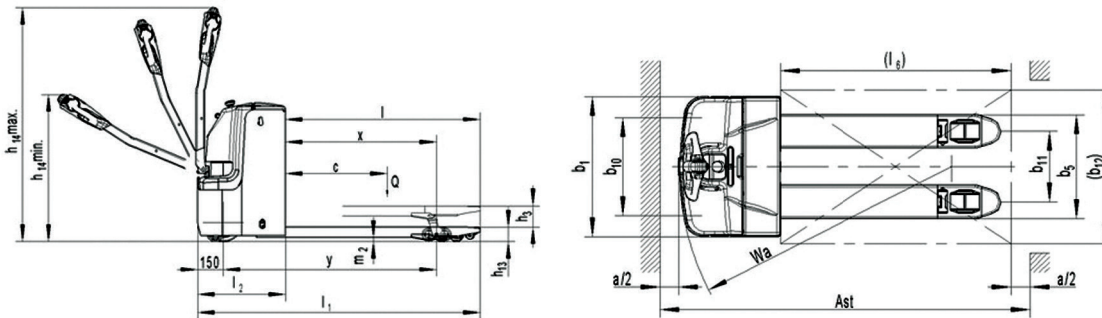

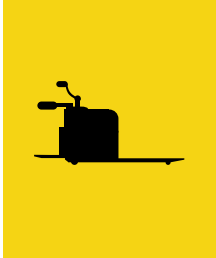

# 6000/8000 LBS HESPTN HEAVY DUTY



## HESPTN HEAVY DUTY PALLET TRUCK

Able to lift and transport loads of 6,000-8,000 lbs, the HESPTN series of self-propelled pallet trucks are designed for heavy duty lifting and transporting applications. These units feature full electric lifting and self-propelled movement with an operator platform, enabling safe and more efficient load handling, particularly in long-distance warehouse applications.

### Features

- AC Drive System
- Comfortable Operator Platform
- Heavy Duty Load Backrest
- Key Switch, Emergency Switch and Battery Discharge Indicator
- Grab Bar w/Electric Controls
- 24 Volt Electrical System
- Standard Battery Compartment Size
- External Charger

Specifications	Model# HESPT60N	Model# HESPT80N
Capacity (lbs):	6,000	8,000
Fork Length:	48"	96"
Overall Fork Width:	22" / 27"	23" / 28"
Raised Fork Height:	9.15"	
Lowered Height:	3.25"	
Fork Dimensions:	2.4" x 9"	2.4" x 10"
Drive Wheels:	12.2" x 4.13"	
Load Rollers:	3.2" x 3.2"	3.2" x 2.76"
Drive Wheels/Load Rollers:	Polyurethane	
Battery Voltage (V/Ah):	24 / 350	
Battery Weight (lbs):	704	
Unit Weight w/Battery (lbs):	2,330	2,465

**U.S. TAILORED OPEN BATTERY COMPARTMENT: 13.8" U.S. tailored open battery compartment ready for wide range of industrial batteries, flexible for different battery dimensions**

**Options: Battery Rollers • Work Equipment Tray**



Control Handle



Grab Bar w/Electric Controls

SKU: HESPT60N, HESPT80N

HESPT60N/HESPT80N HEAVY DUTY PALLET TRUCK				WALKIE / RIDE-ON				
Model	HESPT60N		HESPT80N		HESPT60N		HESPT80N	
Capacity	lbs	6000	8000	Overall Length	(h14) in	91.7	139.8	
Load Center	in	24	48	Overall Width	(l1) in	37 / 37.8	37 / 37.8	
Load Distance (center of drive axle to load wheel)	(x) in	40.5	61.7	Length (to Face of Forks)	(b1) in	43	43	
				Ground Clearance (Center of Wheelbase)	(l2) in	.98	.98	
Wheelbase	(y) in	63.6	83.9	Turning Radius	(m2) in	84.4	104.7	
Weight (with Battery)	lbs	2330	2465	Aisle Width (for pallets: 40" x 48")	(Wa) in	94.5	153.5	
Axle Loading (Laden Front / Rear)	lbs	3100 / 5260	2860 / 5544	Travel Speed (Laden / Un-laden)	(Ast) in	6.2 / 8.7	5.9 / 7.5	
Axle Loading (Unladen Front / Rear)	lbs	1870 / 550	2024 / 440	Lifting Speed (Laden / Un-laden)	ft/s	.125 / .159	.125 / .159	
Drive Wheel (Polyurethane)	in	12.2 dia. x 4.13	12.2 dia. x 4.13	Lowering Speed (Laden / Un-laden)	ft/s	.159 / .159	.159 / .159	
Load Rollers (Polyurethane)	in	3.2 dia. x 3.2	3.2 dia. x 2.76	Gradeability (Laden / Un-laden)	ft/m	8 / 15	6 / 15	
Stabilizer Wheels (Polyurethane)	in	4.9 dia. x 2.4	4.9 dia. x 2.4	Drive Motor Rating S2 60 min	kW	5.1 (AC)	5.1 (AC)	
Tread (Front)	(b10) in	26.8	26.8	Lift Motor Rating at S3 4.5%	kW	3	3	
Tread (Rear)	(b11) in	12.9 / 17.9	12.9 / 17.9	Sound Level (at driver's ear acc. to EN 12053)	dB(A)	68	68	
Lift Height	(h3) in	5.9	5.9	Battery Voltage / Nominal Capacity K5	V/Ah	24 / 350	24 / 350	
Lowered Fork Height	(h13) in	3.25	3.25	Battery Weight	lbs	704	704	
Fork Dimensions	(s/e/l) in	2.4 x 9 x 48	2.4 x 10 x 96	Battery acc. to DIN 43531/35/36 A,B,C, no		No, 5Pzs	No, 5Pzs	
Overall Fork Width (O.D.)	(b5) in	22 or 27	23 or 28	Battery Compartment Size	in	32.7 x 13.7 x 30	32.7 x 13.7 x 30	
Handle Height (in drive position min / max)	(h14) in	34.6 / 61	34.6 / 61	Battery Size	in	32.7 x 12.9 x 23.2	32.7 x 12.9 x 23.2	

\*Because of continual product improvements, specifications may be subject to change without notice

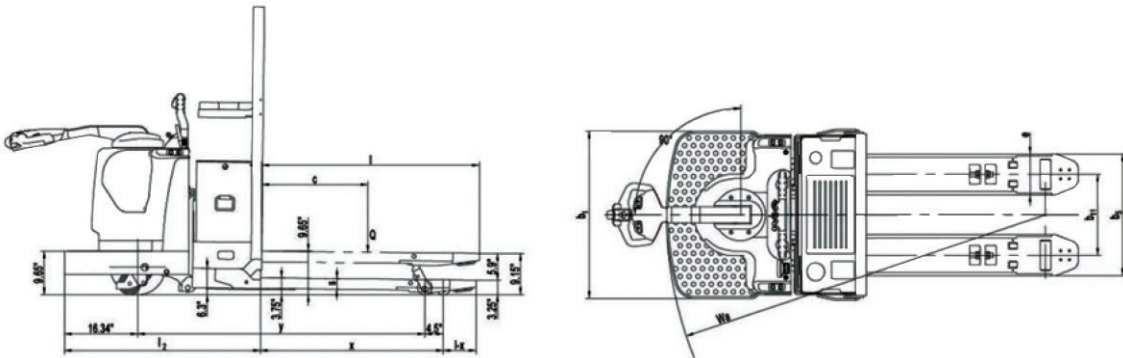

FORK DIMENSIONS		STANDARD FORK TIP						EXTENDED FORK TIP		
Nominal Fork Length	in	36	42	48	54	60	96	84	93	96
Actual Fork Length	(l1) in	35.7	41.7	47.8	53.7	59.7	95.7	83.7	92.8	95.7
Overall Length	(l) in	79.8	85.8	91.8	97.8	103.8	139.8	127.8	136.8	139.8
Wheelbase (Raised)	(y) in	51.4	57.4	63.5	69.5	75.5	111.6	83.9	83.9	83.9
Load Wheel Distance	(x) in	28.4	34.4	40.5	48.4	52.4	88.4	61.7	61.5	61.7
Fork Tip Length	(l-x) in	7.3	7.3	7.3	7.3	7.3	7.3	22	31.3	34
Turning Radius (Raised)	(Wa)	72.3	78.3	84.4	90.4	96.4	132.4	104.7	104.7	104.7
Fork Width	(e)	9						10		

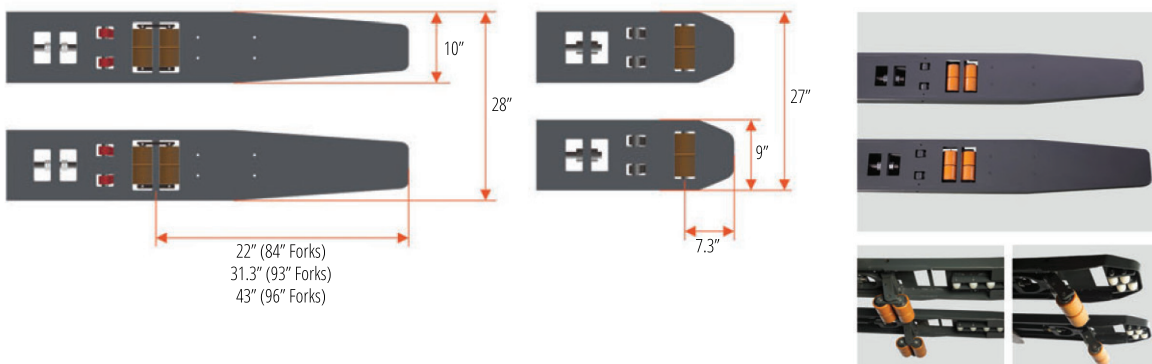



# 4400 LBS ESPT44-LL LOW LIFT



### Features

- Long Handle design for easy and economic operations
- KORDEL Gear Box
- INTORQ Brake
- WICKE Drive Wheel
- Zapf Controller
- CAN-bus Control Handle

### Specifications

Capacity (lbs):	4,400
Fork Length:	45.3"
Overall Fork Width:	22"
Lift Height:	21.7"
Lowered Mast Height:	37.4"
Extended Mast Height:	67.6"
Overall Length:	69.7"
Overall Width:	28.7"
Lead Acid Battery (V/Ah):	24 / 160
Charger (A):	25

### ESPT44-LL LOW-LIFT ELECTRIC PALLET TRUCK

The ESPT44-LL is ideally suited for: Loading and Unloading of Lorries/Trailers, Order Picking Operations within warehouses, and Factory Assembly Lines.

**Options: Battery (24V/210Ah) • Load Backrest • Built-In Charger • Sideway Battery Replacement**

SKU: ESPT44-LL





**ESPT44-LL LOW LIFT ELECTRIC PALLET TRUCK**

**SPECIFICATIONS • PERFORMANCE**

Model		ESPT44-LL
Power		Battery
Operator Type		Pedestrian
Load Capacity (upper and lower pallets)	(Q) lb	4400
Load Capacity (upper pallet)		2200
Load Capacity (lower pallet)		2200
Load Center Distance	(c) in	24
Load Distance (center of drive axle to load wheel)	(x) in	36.1
Wheel Base	(y) in	54.6
Service Weight	lb	1443
Axle Loading - Laden (Front / Rear)	lb	1683 / 4160
Axle Loading - Un-laden (Front / Rear)	lb	1047 / 396
Tires		Polyurethane (PU)
Tire Size, Front	(ØxW) in	Φ9.1 x 2.8
Tire Size, Rear	(ØxW) in	Φ3.1 x 2.8
Additional Wheels (dimensions)	(ØxW) in	Φ3.9 x 1.6
Wheels, number front/rear (x=driven wheels)		1 x + 2 / 4
Tread, Front	(b10) in	20
Tread, Rear	(b11) in	15
Lowered Mast Height	(h1) in	37.4
Lift Height	(h3) in	21.7
Extended Mast Height	(h4) in	67.6
Initial Lifting Height	(h5) in	4.7
Height of Tiller in Drive Position (Min / Max)	(h14) in	33.5 / 54.5
Height, Lowered	(h13) in	3.5
Overall Length	(l1) in	69.7
Length to Face of Forks	(l2) in	24.4
Overall Width	(b1) in	28.7
Fork Dimensions	(s/e/l) in	2.4 / 7.1 / 45.3
Width Across Forks	(b5) in	22
Ground Clearance (center of wheelbase)	(m2) in	1.1
Aisle Width for Pallets 1000 x 1200 crossways	(Ast) in	77.6
Aisle Width for Pallets 800 x 1200 lengthways	(Ast) in	79.5
Turning Radius	(Wa) in	60.5
Travel Speed (Laden / Un-laden)	mph	3.7 / 3.7
Lift Speed (Laden / Un-laden)	fpm	18.7 / 29.5
Lowering Speed (Laden / Un-laden)	fpm	17.7 / 13.8
Gradeability (Laden / Un-laden)	%	8 / 20
Service Brake		Electromagnetic
Drive Motor Rating S2 60min	HP	1.8
Lift Motor Rating at S3 10%	HP	1.6
Battery acc. to DIN 43531/35/36 A, B, C, no		2VBS
Battery Voltage, nominal capacity K5	V/Ah	24 / 160
Battery Weight (minimum)	HP/h	155
Energy Consumption acc. to VDI cycle	lb	.4
Type of Drive Control		AC - Speed Control
Sound Level at driver's ear acc. to EN 12053	db(A)	69

\*Because of continual product improvements, specifications may be subject to change without notice

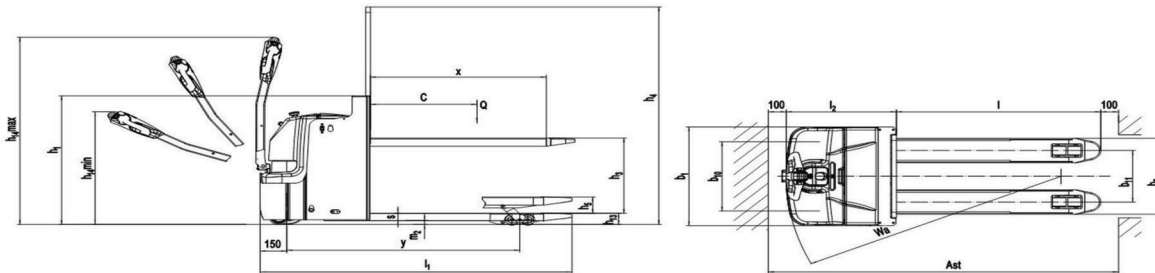

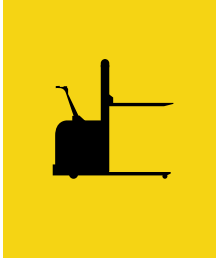

# 2600 LBS LLS26NU LOW-LIFT STRADDLE

### Features

- DC Drive Control
- Smart "Mono-Mast" for increased visibility and operator comfort
- Straddle Type
- Emergency Switch engages the fail-safe electromagnetic brake
- Safety (Belly) Button
- Powerful AGM Battery (2x12Vx85Ah)
- Built-In Charger (24V/12A)

### Specifications

Capacity (lbs):	2,600
Lifting Height:	31.1" / 62.6" / 78.35"
Lowered Fork Height:	1.97"
Battery (V/Ah):	12 / 85
Charger (V/A):	24 / 12
Weight Less Battery (lbs):	1,445 / 1,512 / 1,550

- Options: PIN-Code Panel • Load Backrest  
• Battery (2 x 12V/106Ah) • Lithium Battery**

## LLS26NU LOW-LIFT STRADDLE STACKER

LLS26NU Self-Propelled Stacker with its small size and versatility, is an ideal economic solution for all indoor LIGHT-DUTY and occasional stacking operations.

MAST TABLE FOR MODEL: LLS26NU					
dimensions = inches					
Designation	Lowered Mast Hgt (h1)	Free-Lift Hgt (h2)	Lift Hgt (h3)	Extended Mast Hgt (h4)	Lift+Fork Hgt (h3+h13)
Single-Stage Mast	48.04	26.78	29.14	50.40	31.11
	76.38	55.12	60.63	81.89	62.60
	92.13	70.87	76.39	97.64	78.35

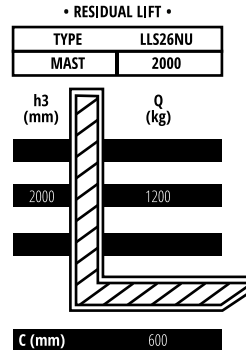

SKU: LLS26NU-31, LLS26NU-63, LLS26NU-78

<b>LLS26NU LOW LIFT STRADDLE STACKER</b>		<b>LLS26NU-31</b>	<b>LLS26NU-63</b>	<b>LLS26NU-78</b>
Model				
Power		Battery		
Operator Type		Pedestrian / Stand		
Load Capacity	lbs	2600		
Load Center	in	23.62		
Wheelbase	in	43.74		
Weight (less battery)	lbs	1445	1512	1550
Wheel Size, Front (Ø x width)	in	8.27 x 2.95		
Wheel Size, Rear (Ø x width)	in	3.31 x 3.66		
Additional Wheels Dimensions (Ø x width)	in	3.94 x 1.57		
Wheels, Number (x=driven wheels) Front / Rear		1x 2 / 2		
Track Width	in	Inside Straddle +3.94		
Lift Height	in	31.1	62.6	78.35
Collapsed Height	in	44.88	76.38	92.13
Extended Height	in	49.76 (65.28 w/o Load Backrest)	81.26 (96.77 w/o Load Backrest)	97.01 (112.52 w/o Load Backrest)
Height of Tiller in Drive Position (Min / Max)	in	28.62 / 45.94		
Outrigger Height	in	3.94		
Lowered Fork Height	in	1.97		
Power Unit Height	in	30.98		
Fork Lengths	in	45.28		
Fork Dimensions (Thickness x Width)	in	1.57 / 3.94		
Width Across Forks	in	9.92 - 31.5		
Headlength	in	25.2		
Overall Length	in	Headlength + Fork Length		
Inside Straddle	in	38.62 / 40.59 / 42.56 / 46.5 / 50.43		
Overall Width	in	31.5 (Front)   Inside Straddle + 7.87 (Rear)		
Fork Carriage Width	in	33.9		
Ground Clearance	in	1.57 (with load below mast)   1.57 (Center Wheelbase)		
Turning Radius	in	52.95		
Length w/Outriggers	in	49.37		
Travel Speed (Laden/Un-laden)	mph	2.61 / 2.8		
Lift Speed (Laden/Un-laden)	fpm	21.65 / 27.56		
Lowering Speed (Laden/Un-laden)	fpm	25.59 / 21.65		
Max Gradeability (Laden / Un-laden)	%	4 / 10		
Service Brake		Electromagnetic		
Battery Voltage / Nominal Capacity 5 Hr Rating	V/Ah	24 / 85 (2 x 12V Maintenance-Free)   24 / 106 (2x 12V Maintenance-Free) 24 / 60 (24V Lithium Battery)		
Type of Drive Control		DC Speed Control		
Battery Weight	lbs	119 (2 x 12V Maintenance-Free)   150 (2 x 12V Maintenance-Free) 37 (24V Lithium Battery)		

\*Because of continual product improvements, specifications may be subject to change without notice

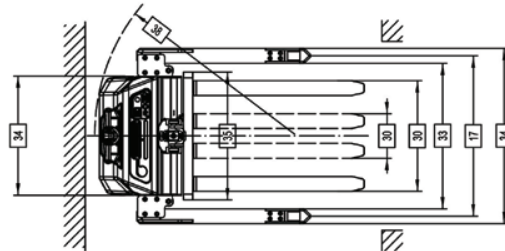
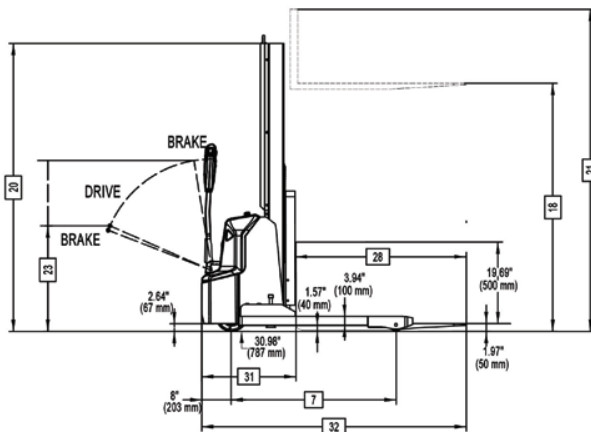

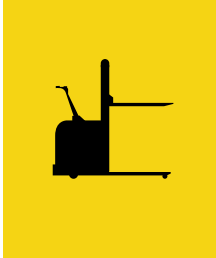

# 2600 LBS LLS26FFNU LOW-LIFT FORK-OVER

### Features

- DC Drive Control
- Smart "Mono-Mast" for increased visibility and operator comfort
- Fixed Forks
- Emergency Button
- Powerful AGM Battery (2x12Vx85Ah)
- Built-In Charger (24V/12A)

### Specifications

Capacity (lbs):	2,600
Lifting Height:	75.35"
Lowered Height:	3.54"
Battery (V/Ah):	12 / 85
Charger (V/A):	24 / 12
Service Weight (lbs):	1,169 / 1,103 (Lithium Model)

- Options: PIN-Code Panel • Load Backrest**  
**• Battery (2 x 12V/106Ah) • Lithium Battery**

## LLS26FFNU LOW-LIFT FORK-OVER STACKER

LLS26FFNU Self-Propelled Stacker with its small size and versatility, is an ideal economic solution for all indoor LIGHT-DUTY and occasional stacking operations.

MAST TABLE FOR MODEL: LLS26FFNU / LLS26FFNU-L					
dimensions = inches					
Designation	Lowered Mast Hgt (h1)	Free-Lift Hgt (h2)	Lift Hgt (h3)	Extended Mast Hgt (h4)	Lift+Fork Hgt (h3+h13)
Single-Stage Mast	47.64	28.11	28.11	47.64	31.50
	75.98	59.61	59.61	75.98	62.99
	91.73	75.35	75.35	91.73	78.74

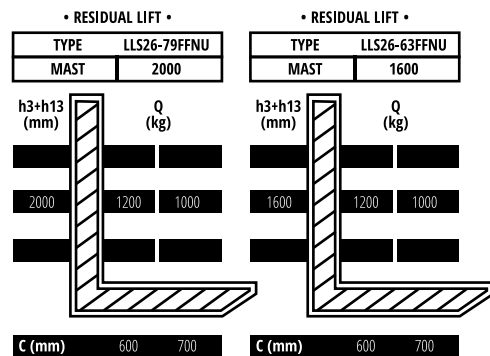

SKU: LLS26FFNU, LLS26FFNU-LITHIUM

**LLS26FFNU LOW LIFT FORK-OVER STRADDLE STACKER**

Model		LLS26FFNU	LLS26FFNU-L (LITHIUM)
Power		Battery	
Operator Type		Pedestrian / Stand	
Load Capacity	(Q) lbs	2645	
Load Center	(C) in	24	
Load Distance (center of drive axle to load wheel)	(X) in	29.92	
Wheelbase	(Y) in	45.16	
Service Weight	lbs	1169	1103
Axle Loading (Laden Front / Rear)	lbs	1102 / 2712	1080 / 2668
Axle Loading (Un-laden Front / Rear)	lbs	827 / 342	783 / 320
Wheels (Front / Rear)		Polyurethane (PU)	
Wheel Size, Front (Ø x width)	in	8.27 x 2.95	
Wheel Size, Rear (Ø x width)	in	3.31 x 3.66	
Additional Wheels Dimensions (Ø x width)	in	3.94 x 1.97	
Wheels, Number (x=driven wheels) Front / Rear		1 x +1 / 2	
Track, Front	(b10) in	21.65	
Track, Rear	(b11) in	15.75	
Lowered Mast Height	(h1) in	91.73 <sup>1)</sup>	
Free Lift Height	(h2) in	75.35	
Lift Height	(h3) in	75.35	
Height of Tiller in Drive Position (Min / Max)	(h4) in	27.95 / 45.28	
Height, Lowered	(h14) in	3.54	
Overall Length	(h13) in	67.32	
Length to Face of Forks	(l1) in	22.05	
Overall Width	(b1) in	31.5	
Fork Dimensions	(s/e/l) in	2.36 / 7.09 / 45.28	
Distance Between Fork Arms	(b5) in	22.44	
Ground Clearance (center of wheelbase)	(m2) in	.94	
Aisle Width (for pallets 1000 x 1200 crossways)	(Ast) in	86.5	
Aisle Width (for pallets 800 x 1200 lengthways)	(Ast) in	84.45	
Turning Radius	(Wa) in	53.15	
Travel Speed (Laden/Un-laden)	mph	2.61 / 2.8	
Lift Speed (Laden/Un-laden)	fpm	21.65 / 27.65	
Lowering Speed (Laden/Un-laden)	fpm	25.59 / 21.65	
Max Gradeability (Laden / Un-laden)	%	5 / 10	
Service Brake		Electromagnetic	
Drive Motor Rating S2 60min	HP	.87	
Lift Motor Rating at S3 7.5%	HP	2.95	
Battery acc. to DIN 43531/35/36 A, B, C, no		No	
Battery Voltage / Nominal Capacity K5	V/Ah	2 x 12 / 85 <sup>2)</sup>	24 / 60
Battery Weight +/- 5%	lbs	2 x 60 <sup>3)</sup>	37
Energy Consumption acc. to VDI cycle	HP/h	.8	
Type of Drive Control		DC Speed Control	
Sound Level (at driver's ear acc. to EN 12053)	dB(A)	<70	

- 1) Include Eyebolt: ±2.17in
- 2) Option: 2 x 12V/106Ah
- 3) 2 x 12V/106Ah: 2 x 75lbs

\*Because of continual product improvements, specifications may be subject to change without notice

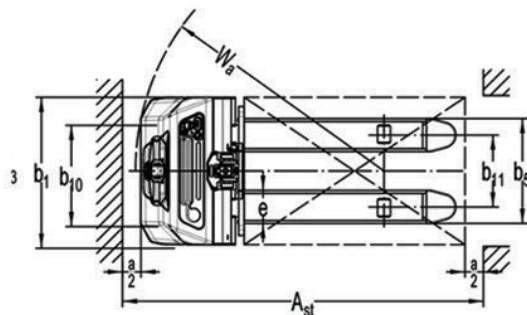
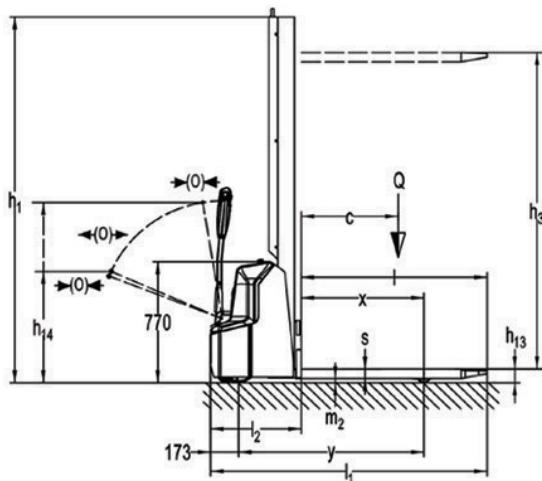

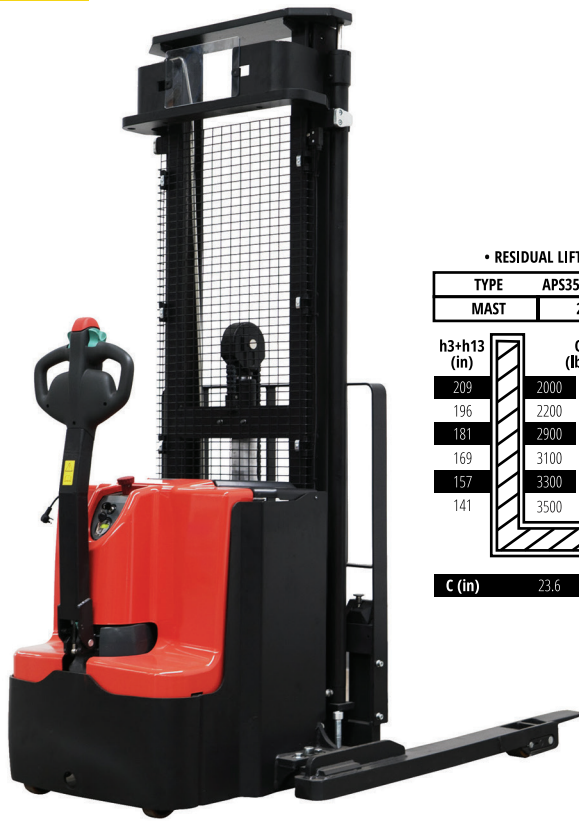
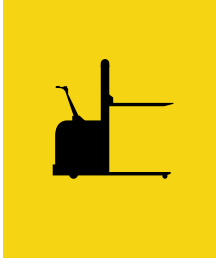

# 2600-3960 LBS APSWLH-SL WALKIE STRADDLE SERIES

• RESIDUAL LIFT •

TYPE	AP35WLH-TSL
MAST	209

h3+h13 (in)	Q (lbs)	
209	2000	1800
196	2200	2000
181	2900	2600
169	3100	2900
157	3300	3100
141	3500	3300

C (in)	23.6	27.6
--------	------	------

### Features

- Ergonomic, Compact, and Safe Long Tiller Handle Design
- Full Proportional Hydraulics System offering precise lifting and lowering
- Maintenance-Free German AC Powertrain
- 4 Wheel Structure for Stability
- External 24V/35A Charger
- Standard Battery: 24V/270Ah (for 3,500-3,900lbs Capacity models)
- Full Free-Lift

### Specifications

Capacity (lbs):	2,600 - 3,960
Lifting Height:	114" - 209"
Lowered Height:	3.54"
Battery (V/Ah):	24 / 180 (APS26)
Battery (V/Ah):	24 / 270 (APS35, APS40)
Charger (V/A):	24 / 35 (Built-In)
Service Weight (lbs):	2,623.5 / 3,262.8 / 3,439.2

### Options: Load Backrest • Side-Shift • Battery (2 x 12V/106Ah)

- Lithium (Battery 24V/150Ah / Charger 24V/60A)
- Lithium (Battery 24V/200Ah / Charger 24V/80A)

## APSWLH-SL WALKIE LONG HANDLE STRADDLE STACKER

The APSWLH-SL Stacker is tailored to most pedestrian controlled stacking operations. By using high quality components, this model will out perform and last longer than comparable stackers on the market. Electronically controlled proportional lifting system increase productivity especially at higher lift heights.

MAST TABLE FOR MODEL: APS35WLH-TSL					
dimensions = inches					
Designation	Lowered Mast Hgt (h1)	Free-Lift Hgt (h2)	Lift Hgt (h3)	Extended Mast Hgt (h4)	Lift+Fork Hgt (h3+h13)
Three-Stage Mast (Full Free-Lift)	75	52	155	176	157
	79	55.9	167	188	169
	83	59.8	178	200	180
	92	69	206	227.6	207.9
MAST TABLE FOR MODEL: APS40WLH-TSL					
dimensions = inches					
Designation	Lowered Mast Hgt (h1)	Free-Lift Hgt (h2)	Lift Hgt (h3)	Extended Mast Hgt (h4)	Lift+Fork Hgt (h3+h13)
Three-Stage Mast (Full Free-Lift)	78	51.6	155	181	157
	84	55.9	167	193	169
	88	59.8	178	205	180



Battery Indicator / USB Port



Powertrain



Straddle Legs

SKU: APS26WLH-TSL142, APS35WLH-TSL181, APS40WLH-TSL-181

**CAP** 2,600-3,950 LBS **↑** 142" - 181" LIFT

**SPECIFICATIONS • PERFORMANCE**

<b>APSWLH-SL WALKIE LONG HANDLE STRADDLE STACKER</b>				
Model		<b>APS26WLH-TSL142</b>	<b>APS35WLH-TSL181</b>	<b>APS40WLH-TSL181</b>
Power		Battery		
Operator Type		Pedestrian / Stand		
Load Capacity	(Q) lbs	2640	3520	3960
Load Center	(C) in	23.6	2.36 <sup>1)</sup>	23.6 <sup>1)</sup>
Load Distance (center of drive axle to load wheel)	(X) in	25.5	26.1 <sup>2)</sup>	25.2 <sup>2)</sup>
Wheelbase	(Y) in	52.4	54.3	54.3
Service Weight	lbs	2623.5	3262.8	3439.2
Axle Loading (Laden Front / Rear)	lbs	1706.4 / 3523	1823.2 / 4967	1966.5 / 5242.6
Axle Loading (Un-laden Front / Rear)	lbs	1755 / 868.6	1904.8 / 1358	2037 / 1402
Tires (Front / Rear)		Polyurethane		
Tire Size, Front (Ø x width)	in	9 x 2.8		
Tire Size, Rear (Ø x width)	in	3.3 x 2.8		
Additional Wheels Dimensions (Ø x width)	in	4 x 1.6		
Wheels, Number (x=driven wheels) Front / Rear		1 x 2 / 4		
Track, Front	(b10) in	19.7		
Lowered Mast Height	(h1) in	91	83	87.7
Free Lift Height	(h2) in	69.3	60	60
Lift Height	(h3) in	140	178.3	178.3
Extended Mast Height	(h4) in	161	200.3	205
Height of Tiller in Drive Position (Min / Max)	(h14) in	37.4 / 56		
Height, Lowered	(h13) in	2		
Overall Length	(l1) in	78.3	82	82.4
Length to Face of Forks	(l2) in	33	36.4	37
Overall Width	(b1/b2) in	32.1 / 46-58		
Fork Dimensions	(s/e/l) in	1.4 x 4 x 45.3	1.6 x 4.7 x 45.3	1.6 X 4.7 x 45.3
Distance Between Fork Arms	(b5) in	9.3 - 28	10 - 28.7	10 - 28.7
Ground Clearance (center of wheelbase)	(m2) in	1.6		
Aisle Width (for pallets 39.4" x 47.2" crossways)	(Ast) in	94.3	96	96.3
Aisle Width (for pallets 31.5" x 47.2" lengthways)	(Ast) in	93.8	95.2	95.7
Turning Radius	(Wa) in	59	61	61
Travel Speed (Laden/Un-laden)	mph	3.4 / 3.7		
Lift Speed (Laden/Un-laden)	fpm	17.72 / 27.56	25.59 / 35.43	25.59 / 35.43
Lowering Speed (Laden/Un-laden)	fpm	49.21 / 39.37	39.37 / 27.56	39.37 / 27.56
Max Gradeability (Laden / Un-laden)	%	6 / 12	6 / 12	6 / 10
Service Brake		Electromagnetic		
Drive Motor Rating S2 60min	HP	1.74	1.88	1.88
Lift Motor Rating at S3 10%	HP	2.01	4.29	4.29
Battery acc. to DIN 43531/35/36 A, B, C, no		2 PZB	3 VBS	3 VBS
Battery Voltage / Nominal Capacity K5	V/Ah	24 / 180	24 / 270	24 / 270
Battery Weight	lbs	386	507	507
Energy Consumption acc. to VDI cycle	kWh/h	.95	1.59	1.7
Type of Drive Control		AC Speed Control		
Sound Level (at driver's ear acc. to EN 12053)	dB(A)	<70		

- 1) With side-shift, load center distance = 19.7in
- 2) With side-shift, load center distance = 2.2in shorter

\*Because of continual product improvements, specifications may be subject to change without notice

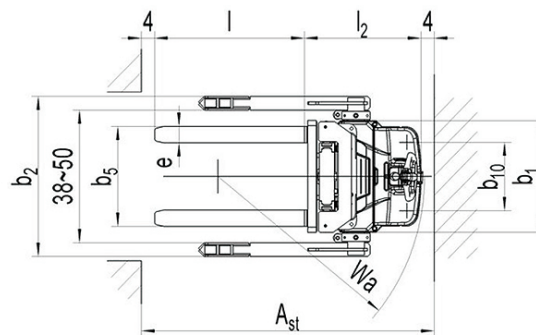
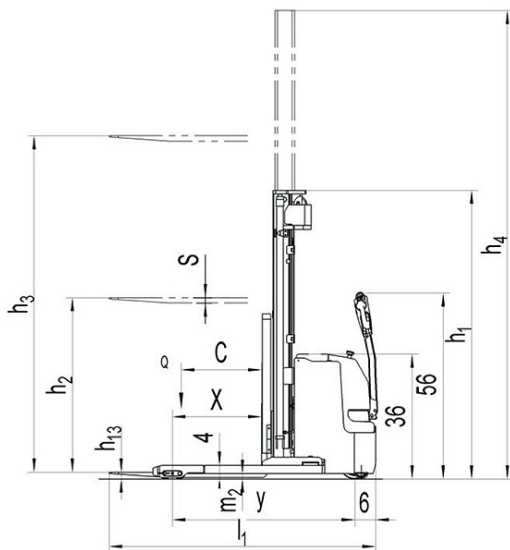

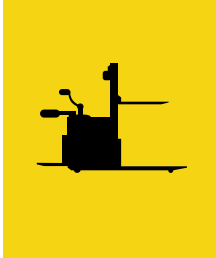

## 2600-4400 LBS APSFFN SERIES HEAVY DUTY FORK-OVER

### • RESIDUAL LIFT •

TYPE	APS35FFN
MAST	5500

h3 (mm)	Q (kg)	
	5500	600
5300	700	400
4600	800	500
4300	900	600
3600	1000	700
3200	1200	900

C (in)	600	700
--------	-----	-----

### Features

- REMA Handle with Contactless Rocker Switches
- Powerful Schabmuller AC Drive Unit
- Top Quality ZF Gearbox
- Intorq Electromagnetic Brake
- Rader Vogel/Wicke PU Drive Wheel
- Integrated Operators Platform/ Protective Arms Design
- Zapi Drive and Steer Controllers

### Specifications

Capacity (lbs):	2,600 - 4,400
Lifting Height:	114" - 216"
Lowered Height:	3.54"
Battery (V/Ah):	24 / 180 (APS26FFN-181)
	24 / 240 (APS35FFN-216)
	24 / 350 (APS44FFN-181)
Charger (V/A):	24 / 25 (APS26FFN-181)
	24 / 30 (APS35FFN-216)
	24 / 35 (APS44FFN-181)
Service Weight (lbs):	2,376 / 3,036 / 3,564

### APSFFN SERIES HEAVY DUTY FORK-OVER STACKER

The APSFFN Stacker is designed to work with high efficiency even during multi-shift operation. More power, with increased speed and battery options, including Lithium solutions.

- Options: PIN-Code Panel Access (works with PIN-Code as well as Access Cards (RFID)) • Electric Power Steering
- Lithium Batteries (fast charging, maintenance-free, environmentally friendly operation)
- Lithium Battery (150Ah with 60A Charger)
- Lithium Battery: (200Ah with 80A Charger)
- Side Battery Replacement • Proportional Lift
- Load Backrest • Full Free-Lift

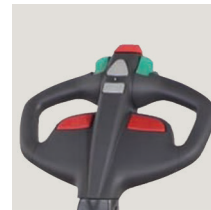

REMA Control Handle



PIN-Code Panel (Optional)



ZAPI Drive / Steering Controller



Electric Power Steering (EPS)

SKU: APS26FFN-181, APS35FFN-216, APS44FFN-181



**CAP** 2,600-4,400 LBS **↑** 141" - 216" LIFT

**SPECIFICATIONS • PERFORMANCE**

APSFN SERIES HEAVY DUTY FORK-OVER STACKER		2 STAGE MAST	3 STAGE MAST	3 STAGE MAST
Model		APS26FFN-181	APS35FFN-216	APS44FFN-181
Power		Battery		
Operator Type		Pedestrian / Stand		
Load Capacity	(Q) lbs	2640	3520	4400
Load Center	(C) in	24		
Load Distance (center of drive axle to load wheel)	(X) in	25.5		
Wheelbase	(Y) in	45.9	47.8	52.2
Service Weight	lbs	2376	3036	3564
Axle Loading (Laden Front / Rear)	lbs	1892 / 3124	2288 / 4268	2662 / 5302
Axle Loading (Un-laden Front / Rear)	lbs	1716 / 704	2068 / 968	2398 / 1188
Tires (Front / Rear)		Polyurethane		
Tire Size, Front (Ø x width)	in	9 x 2.76		
Tire Size, Rear (Ø x width)	in	3.3 x 3		
Additional Wheels Dimensions (Ø x width)	in	5.9 x 2		
Wheels, Number (x=driven wheels) Front / Rear		1 x +1 / 4		
Track, Front / Rear	(b10/b11) in	20.5 (Front)   15.3 / 19.9 (Rear)		
Lowered Mast Height	(h1) in	90.9	94.9	87.7
Free Lift Height	(h2) in	69.3	71.7	59.8
Lift Height	(h3) in	139	213.8	178.3
Extended Mast Height	(h4) in	160.9	240.6	205
Height of Tiller in Drive Position (Min / Max)	(h14) in	37.4 / 53.2		
Height, Lowered	(h13) in	3.5		
Overall Length	(l1) in	73 <sup>1)</sup>	74.6 <sup>1)</sup>	79.7 <sup>1)</sup>
Length to Face of Forks	(l2) in	27.8 <sup>1)</sup>	29.4 <sup>1)</sup>	34.5 <sup>1)</sup>
Overall Width	(b1/b2) in	31.1		
Fork Dimensions	(s/e/l) in	2.4 / 7.1 / 45.3		
Distance Between Fork Arms	(b5) in	22.4 / 27		
Ground Clearance (center of wheelbase)	(m2) in	1.1	1.1	.9
Aisle Width (for pallets 39.4" x 47.2" crossways)	(Ast) in	90 <sup>1)</sup>	91.5 <sup>1)</sup>	96.7 <sup>1)</sup>
Aisle Width (for pallets 31.5" x 47.2" lengthways)	(Ast) in	88.6 <sup>1)</sup>	90.2 <sup>1)</sup>	95.3 <sup>1)</sup>
Turning Radius	(Wa) in	54.3 <sup>1)</sup>	55.9 <sup>1)</sup>	61 <sup>1)</sup>
Travel Speed (Laden/Un-laden)	mph	4.4 / 5	4.4 / 5	3.7 / 4.4
Lift Speed (Laden/Un-laden)	fpm	17.7 / 27.6	25.6 / 39.4	25.6 / 39.4
Lowering Speed (Laden/Un-laden)	fpm	49.2 / 39.4	55.1 / 45.3	55.1 / 45.3
Max Gradeability (Laden / Un-laden)	%	6 / 12	6 / 12	6 / 10
Service Brake		Electromagnetic		
Drive Motor Rating S2 60min	HP	1.9		
Lift Motor Rating at S3 10%	HP	2	4.3	4.3
Battery acc. to DIN 43531/35/36 A, B, C, no		2 VBS	3 VBS	3 PZS
Battery Voltage / Nominal Capacity K5	V/Ah	24 / 180	24 / 240	24 / 350
Battery Weight	lbs	385	506	634
Energy Consumption acc. to VDI cycle	kWh/h	.95	1.34	1.7
Type of Drive Control		AC Speed Control		
Sound Level (at driver's ear acc. to EN 12053)	dB(A)	<70		

1) With unfolded platform: +17.3in

\*Because of continual product improvements, specifications may be subject to change without notice

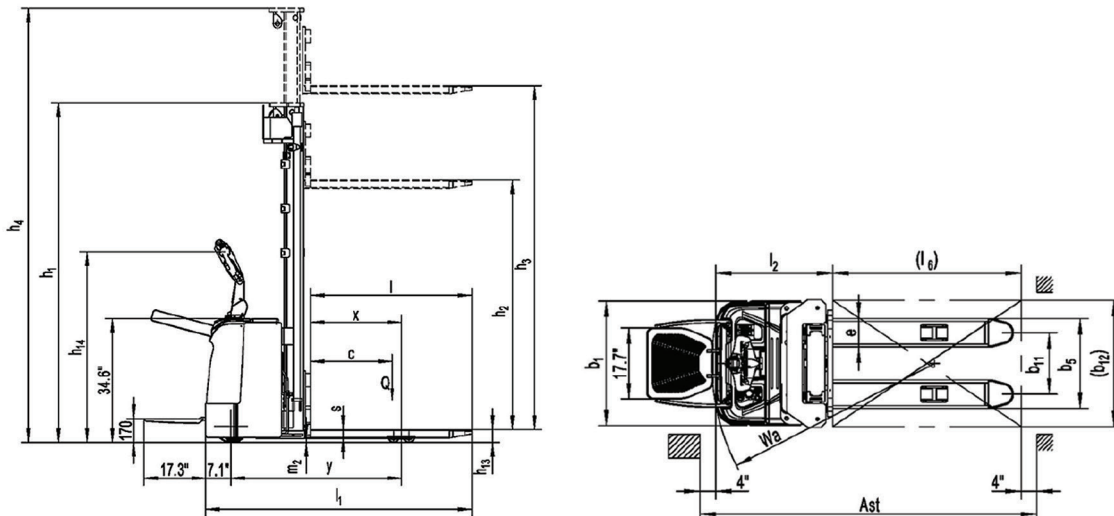

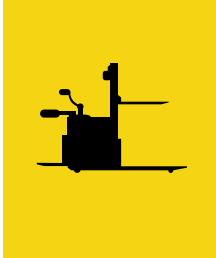

• RESIDUAL LIFT •

TYPE		APS35DFFN	
MAST		4600	

h3 (mm)	Q (kg)	
4600	500	300
4300	600	400
4000	700	500
3600	800	600
3200	1000	800
2900	1300	1100
2500	1600	1200

C (in)	600	700
--------	-----	-----

# 3500 LBS

# APS35DFFN

## FORK-OVER DUAL LIFTING

### Features

- Powerful Schabmueller AC Drive Unit
- Top Quality ZF Gearbox
- Intorq Electromagnetic Brake
- Drive Speeds up to 8km p/hr
- German Rader Vogel or Wicke Drive Wheels (ensure long life of PU wheels)
- Zapi Controllers with high reliability
- 8mm thick Apron ensures robust chassis

### Specifications

Capacity (lbs):	3,500
Lifting Height:	187.3"
Lowered Height:	3.5"
Battery (V/Ah):	24 / 270
Charger (V/A):	24 / 30
Service Weight (lbs):	3,196.7

**Options: Electric Power Steering (EPS) • PIN-Code Panel (significantly simplifies access limitation for the fleet)**

### APS35DFFN FORK-OVER DUAL LIFTING STACKER

The APS35DFFN Stacker is designed to work with high efficiency even during multi-shift operation. More power, with increased speed and various battery options, including Lithium solutions.



Schabmueller AC Drive Motor



PIN-Code Panel (Optional)

MAST TABLE FOR MODEL: APS35DFFN					
dimensions = inches					
Designation	Lowered Mast Hgt (h1)	Free-lift Hgt (h2)	Lift Hgt (h3)	Extended Mast Hgt (h4)	Lift+Fork Hgt (h3+h13)
Two-Stage Mast	77.1	-	111.4	133.1	114.2
	83	-	123.2	144.9	126
	90.9	-	139	160.6	141.7
Two-Stage Mast (Full Free-Lift)	77.1	55.5	111.4	133.1	114.2
	83	61.4	123.2	144.9	126
	90.9	69.3	139	160.6	141.7
Three-Stage Mast	79.1	-	166.5	188.2	169.3
	83	-	178.3	200	181.1
Three-Stage Mast (Full Free-Lift)	75.1	52	154.7	176.4	157.5
	79.1	55.9	166.5	188.2	169.3
	83	59.8	178.3	200	181.1



ZAPI Drive / Steering Controller



Electric Power Steering (EPS)

SKU: APS35DFFN



3,500 LBS



114" - 181" LIFT

APS35DFFN FORK-OVER DUAL LIFTING STACKER

SPECIFICATIONS • PERFORMANCE

Model		APS35DFFN
Power		Battery
Operator Type		Pedestrian
Load Capacity	(Q) lbs	3527
Initial Lift Load Capacity	(Q) lbs	3527
Forks Load Capacity	(Q) lbs	3527
Load Center Distance	(C) in	23.6
Load Distance (center of drive axle to load wheel)	(X) in	30.2 <sup>1)</sup>
Wheelbase	(Y) in	58.3 <sup>1)</sup>
Service Weight	lbs	3196.7
Axle Loading (Laden Front / Rear)	lbs	2601.5 / 4122.6
Axle Loading (Un-laden Front / Rear)	lbs	2292.8 / 903.9
Tires (Front / Rear)		Polyurethane
Tire Size, Front (Ø x width)	in	9 x 2.8
Tire Size, Rear (Ø x width)	in	3 x 2.8
Additional Wheels Dimensions (Ø x width)	in	6 x 2.1
Wheels, Number (x=driven wheels) Front / Rear		1 x +1 / 4
Tread, Front	(b10) in	20.4
Tread, Rear	(b11) in	15.4 / 19.9
Lowered Mast Height	(h1) in	82.9
Free Lift Height	(h2) in	59.8
Lift Height	(h3) in	187.3
Extended Mast Height	(h4) in	200
Initial Lift	(h5) in	4.7
Height of Tiller in Drive Position (Min / Max)	(h14) in	37.4 / 53.1
Height, Lowered	(h13) in	3.5
Overall Length	(l1) in	80.5 <sup>1)</sup>
Length to Face of Forks	(l2) in	35.2 <sup>1)</sup>
Overall Width	(b1) in	31.1
Fork Dimensions DIN 150 2331	(s/e/l) in	2.4 / 7.1 / 45.3
Width Across Forks	(b5) in	22.4 / 27
Ground Clearance (center of wheelbase)	(m2) in	.8
Aisle Width (for pallets 1000 x 1200 crossways)	(Ast) in	101.8 <sup>2)</sup>
Aisle Width (for pallets 800 x 1200 lengthways)	(Ast) in	101 <sup>2)</sup>
Turning Radius	(Wa) in	66.9 <sup>2)</sup>
Travel Speed (Laden/Un-laden)	mph	3.7 / 4.3
Lift Speed (Laden/Un-laden)	fpm	17.72 / 27.56
Lowering Speed (Laden/Un-laden)	fpm	49.21 / 39.37
Max Gradeability (Laden / Un-laden)	%	6 / 12
Service Brake		Electromagnetic
Drive Motor Rating S2 60min	HP	1.883
Lift Motor Rating at S3 10%	HP	4.29
Battery acc. to DIN 43531/35/36 A, B, C, no		3 VBS
Battery Voltage / Nominal Capacity K5	V/Ah	24 / 270
Battery Weight	lbs	507
Energy Consumption acc. to DIN EN 16796	kWh/h	.73
Type of Drive Control		AC Speed Control
Sound Level (at driver's ear acc. to EN 12053)	dB(A)	<70

1) When platform is folded: -2.91in

2) When platform is extended: +17.32in

\*Because of continual product improvements, specifications may be subject to change without notice

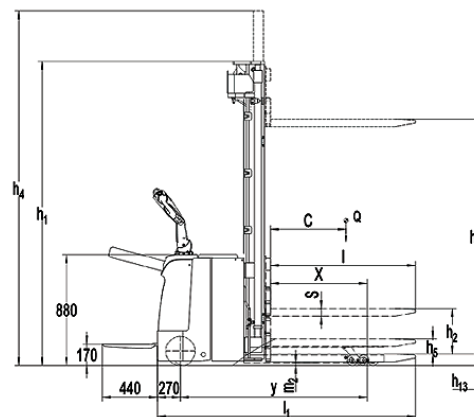
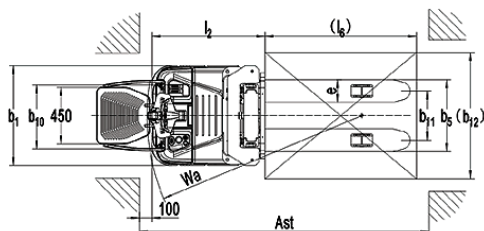

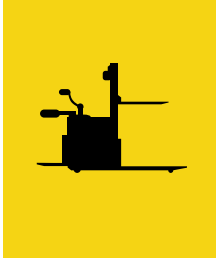

### CBS28N COUNTER BALANCE STACKER

The ECO CBS self-propelled stacker is designed to handle a wide variety of heavy-duty applications. Able to lift loads up to 2,860 lbs to a maximum height ranging from 118" – 177", this state-of-the-art stacker also extends loads to a maximum of 22.8".

SKU: CBS28-118-N, CBS28-141-N, CBS28-177-N

2800 LBS

# CBS28N



#### Features

- German REMA CAN-BUS Handle
- Hydr-App Pump Unit
- CURTIS AC Controller
- Wicke Drive Wheel
- Extentable Mast
- MOSFET Drive System
- Key Switch, Emergency Switch and Battery Discharge Indicator
- Tilt Function
- Walkie Platform w/Foldable Safety Arms
- Power Steering
- Beverage Holder
- Standard Battery Compartment Size
- 24 Volt Electric System
- External Charger

#### Specifications

	Model# CBS28-118	Model# CBS28-141	Model# CBS28-177
Capacity (lbs):	2,860		
Raised Fork Height:	118.1"	141.7"	177.1"
Raised Mast Height:	152.9"	176.6"	212"
Lowered Mast Height:	82.5"	70.7"	82.5"

Options: 'Side-Shift' (rated @ 2,360 lbs Capacity): allows load to be moved left and right without the need to move the whole truck itself (particularly useful when operating within tight spaces) • Side Battery Pull



Ride-On Platform



Key Switch, Battery Discharge Indicator, Emergency Switch

#### • RESIDUAL LIFT •

TYPE	CBS28-177
MAST	177

h3 (in)	Q (lbs)	
175	1760	1540
141	2200	1980
116	2420	2200
98	2860	2860
C (in)	23.6	27.5

**CAP** 2,860 LBS **↑** 118.1" - 177.1" LIFT

**SPECIFICATIONS • PERFORMANCE**

CBS28N COUNTER BALANCE STACKER		2 STAGE MAST		
Model		CBS28-118	CBS28-141	CBS28-177
Capacity	lbs	2860		
Load Center	in	23.6		
Load Distance (center of drive axle to load wheel)	(x) in	15.9		
Wheelbase	(y) in	53.8		
Weight (with Battery)	lbs	4180	4620	4730
Axle Loading (Laden Front / Rear)	lbs	3483 / 3836	3703.8 / 4089.6	3902 / 4387
Axle Loading (Unladen Front / Rear)	lbs	3295 / 1157	3648 / 1278	4012 / 1411
Drive Wheel (Polyurethane)	in	9.8 dia. x 3.2		
Load Rollers (Polyurethane)	in	8.3 dia. x 3.3		
Stabilizer Wheels (Polyurethane)	in	4.9 dia. x 2.3		
Tread (Front)	(b10) in	26.7		
Tread (Rear)	(b11) in	39.1		
Lift Height	(h3) in	118.1	141.7	177.1
Lowered Mast Height	(h1) in	82.52	70.7	82.5
Raised Mast Height	(h4) in	152.9	176.6	212
Lowered Fork Height	(h13) in	2		
Free Lift	(h2) in	0	47.24	59.05
Fork Dimensions	(s/e/l) in	1.4 x 3.9 x 45.3		
Overall Fork Width (O.D.)	(b5) in	7.9 - 29.9		
Reach Distance	(l4) in	21.26		
Handle Height (in drive position min / max)	(h14) in	40.7 / 55.7		
Overall Length	(l1) in	84.25		
Overall Width	(b1) in	42.9		
Length (to Face of Forks)	(l2) in	46.85		
Ground Clearance (Center of Wheelbase)	(m2) in	1.53		
Turning Radius	(Wa) in	62.7		
Aisle Width (for pallets: 40" x 48")	(Ast) in	103.9		
Travel Speed (Laden / Un-laden)	mph	3.1 / 3.4		
Lifting Speed (Laden / Un-laden)	ft/s	.27 / .36	.36 / .54	
Lowering Speed (Laden / Un-laden)	ft/s	.41 / .26	.32 / .31	
Gradeability (Laden / Un-laden)	%	5 / 8		
Drive Motor Rating S2 60 min	kW	1.6 (MOSFET)		
Lift Motor Rating at S3 4.5%	kW	2.2	3	
Sound Level (at driver's ear acc. to EN 12053)	dB(A)	67		
Battery Voltage / Nominal Capacity K5	V/Ah	24 / 270	24 / 400	
Battery acc. to DIN 43531/35/36 A,B,C, no		A, 3Pzs	A, 4Pzs	
Battery Compartment Size	in	33.5 x 11.5 x 25.6		
Battery Size	in	32.7 x 10.7 x 24.7		

\*Because of continual product improvements, specifications may be subject to change without notice

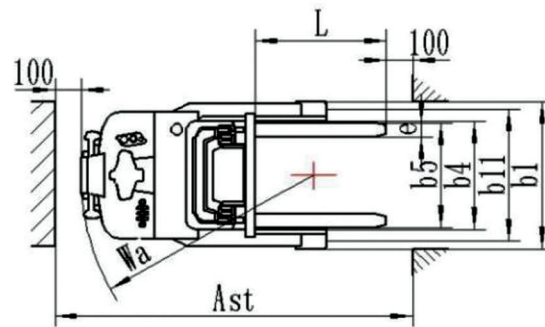
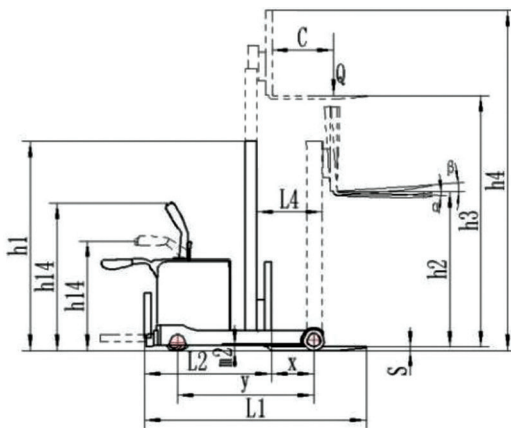

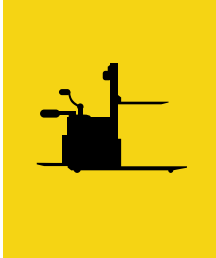

# 1980-4000 LBS CBSN SERIES COUNTER BALANCE

• RESIDUAL LIFT •

TYPE		CBSN SERIES	
MAST		177	
h3 (in)		Q	
		(lbs)	
	177	1984	1323
	169	2205	1543
	157	2646	1984
142	3086	2425	
130	3527	2866	
C (in)		19.7	23.6



## Features

- Compact design; small wheelbase and turning radius
- Integrated Foldable Ride-On Platform & Safety Side Arms supporting smaller turning radius
- Mast forward / backward movement provides enhanced stability and safety
- Side battery extraction ensures a fast/convenient battery replacement
- ZAPI Controllers
- Powerful Schabmueller AC Drive Motor
- KORDEL Gearbox
- Rader Vogel or Wicke Drive Wheels

## Specifications

Capacity (lbs):	1,980 - 4,000
Lifting Height:	187.3"
Lowered Height:	3.5"
Battery (V/Ah):	24 / 270
Charger (V/A):	24 / 35
Service Weight (lbs):	3,196.7

- Options:** French HPI Hydraulic System for full proportional lifting (ensures precise load position during lifting/lowering)
- PIN-Code Panel
  - Automatic filling system for quick lead acid battery refill
  - 350Ah Battery/45A Charger (CBS30N and CBS33N models)
  - 42-45"/48"/54"/60" Fork Lengths
  - Lithium Battery: 24V/200AH with 24V/80A Charge

## CBSN SERIES COUNTER BALANCE STACKER

Rated load capacity of this counter balance stacker series ranges from 1,980-4000 lbs. Compact structure, providing an excellent operational experience.

MAST TABLE FOR MODEL: CBSN SERIES					dimensions = inches
Designation	Lowered Mast Hgt (h1)	Free-Lift Hgt (h2)	Lift Hgt (h3)	Extended Mast Hgt (h4)	Mast Specification
Single-Stage Mast	86	-	63	96	65
	73	-	98	132	101
Two-Stage Mast	83	-	118	152	120
	87	-	126	159	128
	94	-	142	175	144
	102	-	157	191	160
Three-Stage Mast (Full Free-Lift)	71	47	142	175	144
	76	52	157	191	160
	80	56	169	203	172
	83	59	177	211	180

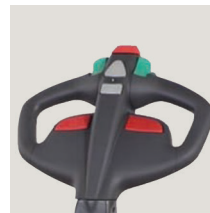

REMA Control Handle



PIN-Code Panel (Optional)



Multi-Function Instrument Panel



Electric Power Steering (EPS)

SKU: CBS20N, CBS30N, CBS33N, CBS40N

**CAP** 1,980-4,000 LBS **↑** 177" LIFT

**CBSN SERIES COUNTER BALANCE STACKER**

Model		CBS20N	CBS30N	CBS33N	CBS40N
Power		Battery			
Operator Type		Pedestrian			
Load Capacity	(Q) lbs	1980	3000	3300	3000
Load Center Distance	(C) in	23.6			
Load Distance (center of drive axle to load wheel)	(X) in	6			
Wheelbase	(Y) in	53.1	57.1	66.9	
Service Weight	lbs	4763	4980	5390	5610
Axle Loading (Laden Front / Rear)	lbs	1067 / 5676	905 / 6934	1267 / 7423	1147 / 9463
Axle Loading (Un-laden Front / Rear)	lbs	2167 / 2596	2383 / 2596	2724 / 2666	2944 / 2666
Tires (Front / Rear)		Polyurethane			
Tire Size, Front (Ø x width)	in	9.84 x 3.22			
Tire Size, Rear (Ø x width)	in	9.05 x 3.93			
Wheels, Number (x=driven wheels) Front / Rear		1 x / 2			
Track, Front	(b10) in	-			
Track, Rear	(b11) in	39			
Tilt of Mast/Fork Carriage (Forward / Backward)	$\alpha/\beta(^{\circ})$	1.5 / 3.5			
Lowered Mast Height	(h1) in	83			
Free Lift Height	(h2) in	59			
Lift Height	(h3) in	177			
Extended Mast Height	(h4) in	210			
Height of Tiller in Drive Position (Min / Max)	(h14) in	38 / 54			
Height, Lowered	(h13) in	2.36			
Overall Length	(l1) in	106	109	120	
Length to Face of Forks	(l2) in	69	72	78	
Overall Width	(b1) in	43			
*Fork Dimensions (Standard Fork Length: 37.4")	(s/e/l) in	1.37 / 3.93 / 45.27		1.57 / 4.72 / 45.27	
Distance Between Fork Arms	(b5) in	8.66 - 29.92			
Ground Clearance (center of wheelbase)	(m2) in	2.04			
Aisle Width (for pallets 1000 x 1200 crossways)	(Ast) in	122	126	132	
Aisle Width (for pallets 800 x 1200 lengthways)	(Ast) in	127	130	136	
Turning Radius	(Wa) in	63	67	73	
Travel Speed (Laden/Un-laden)	mph	4.35 / 4.97		3.72 / 4.35	
Lift Speed (Laden/Un-laden)	fpm	27.56 / 39.37	23.62 / 39.37	19.68 / 39.37	
Lowering Speed (Laden/Un-laden)	fpm	49.21 / 39.4	59.05 / 39.37	62.99 / 39.37	
Max Gradeability (Laden / Un-laden)	%	6 / 15			
Service Brake		Electromagnetic			
Drive Motor Rating S2 60min	HP	3.48			
Lift Motor Rating at S3 10%	HP	4.29			
Battery acc. to DIN 43531/35/36 A, B, C, no		DIN			
Battery Voltage / Nominal Capacity K5	V/Ah	24 / 270		24 / 350	
Battery Weight	lbs	515		693	
Energy Consumption acc. to VDI cycle	kWh/h	1.8	1.88	1.9	
Type of Drive Control		AC Speed Control			
Sound Level (at driver's ear acc. to EN 12053)	dB(A)	<68			

**SPECIFICATIONS • PERFORMANCE**

\*Because of continual product improvements, specifications may be subject to change without notice

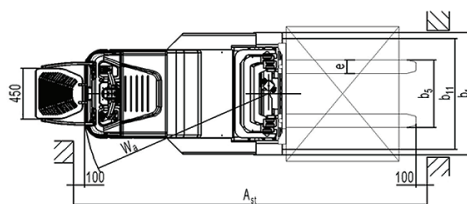
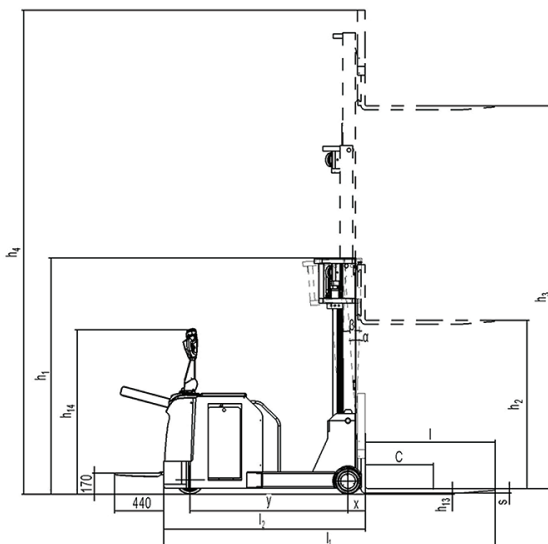

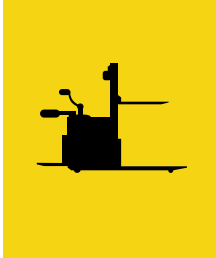

## 3300-4400 LBS RT SERIES STAND-ON REACH TRUCK

### Features

- Effortless 360° Steering in confined spaces with small turning radius
- Compact Chassis allows easy access to narrow aisle applications
- Versatile Battery Capacities for multiple operation time
- Automatic de-celeration when cornering
- Adaptive Safety Load-Sensing System
- Dual Foot Pedals for higher efficiency
- Full Proportional Hydraulic Control
- Robust Scissor Structure minimizing vibrations and rocking
- Ergonomically designed multifunctional integrated Handle
- Automatic Fork Levelling Function
- One-Touch Levelling Function (ensures stable loading/unloading)

### Specifications

Capacity (lbs):	3,300
Lifting Height:	177" - 413"
Lowered Height:	N/A
Battery (V/Ah):	SEE CHART (NEXT PG)
Charger (V/A):	SEE CHART (NEXT PG)
Service Weight (lbs):	N/A

### RT33SP / RT33DP / RT44SP STAND-ON REACH TRUCK

The RT Stand-On Series Reach Trucks are an ideal choice for high rack applications with heavy load capacity (3,300-4,400 lbs) and max lift height up to 413". With its integrated reach forward mast and small turning radius, the bottom shelf of the rack is no longer an obstacle. Perfect solution for large warehouses with narrow aisle racks for efficient storage of goods.

#### Advantages:

- Regenerative braking minimises wear and ensures braking safety
- AC Drive system and EPS combined with Curtis Controller, Schabmueller Drive and Steer Motor, ZF Gear Box and German Mast Profile
- High quality H-Shaped Mast with reaching capability
- Increased truck safety and operating comfort with buffer system for fork lowering and lateral mast movement

SKU: SEE CHART NEXT PAGE





**RT33SP SINGLE SCISSOR (STAND-UP) REACH TRUCK**

Model		RT33SP			
Power		Electric	Fork Carriage Width (includes Load Backrest)	(b3) in	32.3
Operator Type		Stand	Width Across Forks (with/without side-shifter)	(b5) in	7.9 - 29.9
Load Capacity	(Q) lbs	3307	Inside Straddle	(b4) in	41.3 / 50
Load Center	(C) in	23.6	Reach (with/without side-shifter)	(l4) in	23.2
Load Distance	(X) in	12 / 10.4	Ground Clearance (Center Wheelbase)	(m2) in	2
Tires, Front (Ø x width)	in	13.5 x 5.5	Width Outrigger	(b2) in	51
Tires, Rear (Ø x width)	in	5 x 2.9	Travel Speed (Standard)	mph	5.6 / 5.9
Caster Wheel (Ø x width)	in	8 x 4	Lift Speed	fps	1.15 / 1.64
Wheels (x = driven wheels)		1 x + 1 / 4	Lower Speed	fps	1.64 / 1.64
Track Width	(b10) in	31.5	Reach Speed (Laden/Un-laden)	fps	.49 / .49
Tilt Fork Carriage (Forward / Backward)	(Angle/°)	¾	Max Gradeability (Laden)	%	5
Outrigger Height	(h8) in	4.9	Brakes	%	Electric
Overall Width	(b1) in	42.5	Traction Motor	kW	5.5
Fork Dimensions (T x L x W)	in	1.6 x 3.9 x 42.1	Lift Motors	kW	11
Fork Carriage (DIN 15173 class/form A B)		2A	Type of Controller		AC

\*Because of continual product improvements, specifications may be subject to change without notice

TYPE		B	C	D	E
Wheelbase	(y) in	61	61	63	65
Headlength	(lz) in	59.1	59.1	61	63
Working Aisle Width (1000 x 1200 traverse)	(Ast) in	115.9	115.9	117.9	119.9
Working Aisle Width (800 x 1200 length)	(Ast) in	118.3	118.3	120.3	122.2
Turning Radius	(Wa) in	71.9	71.9	73.8	75.8
Length over Outriggers	(lr) in	78.1	78.1	80.1	82.1
Max. Battery Size	L x W x H	14.2 x 38.6 x 30.9	16.1 x 38.6 x 30.9	16.1 x 38.6 x 30.9	19.7 x 38.6 x 30.9
Battery Voltage	V/Ah	36V/600Ah	36V/700Ah	36V/800Ah	36V/900Ah
Battery Weight	lbs	1720	1984	2260	2513

MAST MODEL		33SP177	33SP193	33SP256	33SP295	33SP334	33SP374	33SP413
Battery Pack Model	B	RT33SP4500B	RT33SP4920B	RT33SP6500B	n/a	n/a	n/a	n/a
	C	RT33SP4500C	RT33SP4920C	RT33SP6500C	RT33SP7500C	n/a	n/a	n/a
	D	RT33SP4500D	RT33SP4920D	RT33SP6500D	RT33SP7500D	RT33SP8500D	n/a	n/a
	E	RT33SP4500E	RT33SP4920E	RT33SP6500E	RT33SP7500E	RT33SP8500E	RT33SP9500E	RT33SP10500E

MAST MODEL		33SP177	33SP193	33SP256	33SP295	33SP334	33SP374	33SP413
Battery Pack Model	B	7826	7915	8267	8488	8708	n/a	n/a
	C	8091	8179	8532	8752	8973	9215	n/a
	D	8378	8466	8818	9039	9259	9480	9700
	E	8642	8730	9083	9304	9524	9744	9965

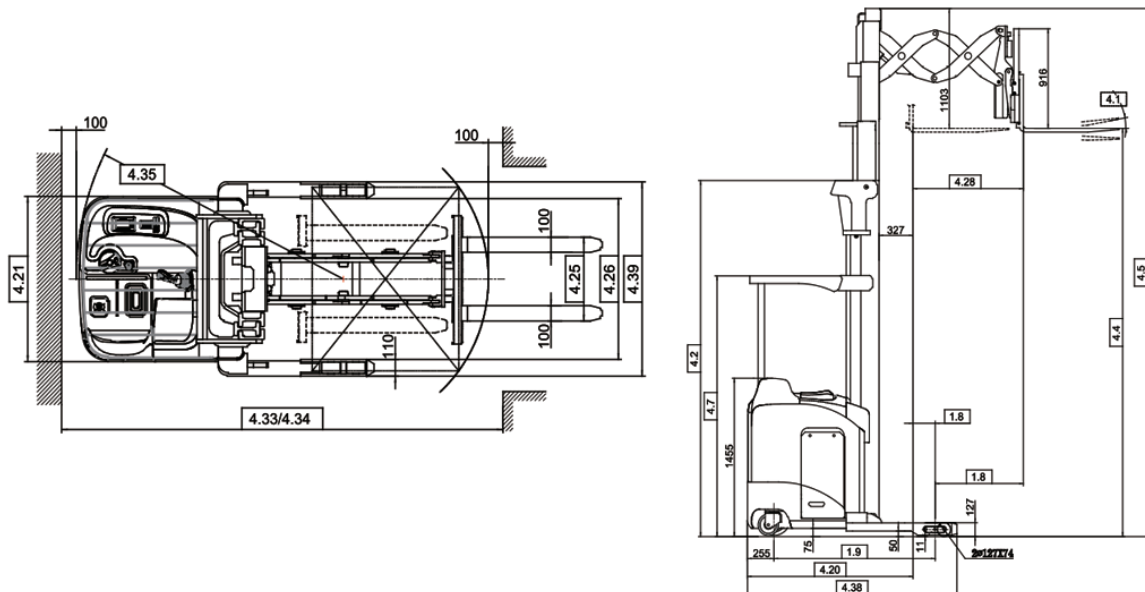

**RT33DP DOUBLE SCISSOR (STAND-UP) REACH TRUCK**

Model		RT33DP			
Power		Electric	Fork Carriage Width (includes Load Backrest)	(b3) in	32.3
Operator Type		Stand	Width Across Forks (with/without side-shifter)	(b5) in	7.9 - 29.9
Load Capacity	(Q) lbs	3307	Inside Straddle	(b4) in	41.3 / 50
Load Center	(C) in	23.6	Reach (with/without side-shifter)	(l4) in	41.7
Load Distance	(X) in	8.39 / 33.35	Ground Clearance (Center Wheelbase)	(m2) in	2
Tires, Front (Ø x width)	in	13.5 x 5.5	Width Outrigger	(b2) in	51
Tires, Rear (Ø x width)	in	5 x 2.9	Travel Speed (Standard)	mph	5.6 / 5.9
Caster Wheel (Ø x width)	in	8 x 4	Lift Speed	fps	1.15 / 1.64
Wheels (x = driven wheels)		1 x + 1 / 4	Lower Speed	fps	1.64 / 1.64
Track Width	(b10) in	31.5	Reach Speed (Laden/Un-laden)	fps	.49 / .49
Tilt Fork Carriage (Forward / Backward)	(Angle/°)	¾	Max Gradeability (Laden)	%	5
Outrigger Height	(h8) in	4.9	Brakes	%	Electric
Overall Width	(b1) in	42.5	Traction Motor	kW	5.5
Fork Dimensions (T x L x W)	in	1.6 x 3.9 x 42.1	Lift Motors	kW	11
Fork Carriage (DIN 15173 class/form A B)		2A	Type of Controller		AC

\*Because of continual product improvements, specifications may be subject to change without notice

**SPECIFICATIONS • PERFORMANCE**

TYPE		B	C	D	E
Wheelbase	(y) in	61	61	63	65
Headlength	(l2) in	62.6	62.6	64.6	66.5
Working Aisle Width (1000 x 1200 traverse)	(Ast) in	118.7	118.7	120.7	122.6
Working Aisle Width (800 x 1200 length)	(Ast) in	121.7	121.7	123.6	125.6
Turning Radius	(Wa) in	71.9	71.9	73.8	75.8
Length over Outriggers	(l7) in	78.1	78.1	80.1	82.1
Max. Battery Size	L x W x H	14.2 x 38.6 x 30.9	16.1 x 38.6 x 30.9	16.1 x 38.6 x 30.9	19.7 x 38.6 x 30.9
Battery Voltage	V/Ah	36V/600Ah	36V/700Ah	36V/800Ah	36V/900Ah
Battery Weight	lbs	1720	1984	2260	2513

MAST MODEL		33DP177	33DP193	33DP256	33DP295	33DP334	33DP374	33DP413
Battery Pack Model	B	RT33DP4500B	RT33DP4920B	RT33DP6500B	n/a	n/a	n/a	n/a
	C	RT33DP4500C	RT33DP4920C	RT33DP6500C	RT33DP7500C	n/a	n/a	n/a
	D	RT33DP4500D	RT33DP4920D	RT33DP6500D	RT33DP7500D	RT33DP8500D	n/a	n/a
	E	RT33DP4500E	RT33DP4920E	RT33DP6500E	RT33DP7500E	RT33DP8500E	RT33DP9500E	RT33DP10500E

MAST MODEL		33DP177	33DP193	33DP256	33DP295	33DP334	33DP374	33DP413
Battery Pack Model	B	8805	8929	9348	n/a	n/a	n/a	n/a
	C	9070	9193	9612	9877	n/a	n/a	n/a
	D	9367	9491	9910	10174	10439	n/a	n/a
	E	9643	9766	10185	10450	10714	10979	11244

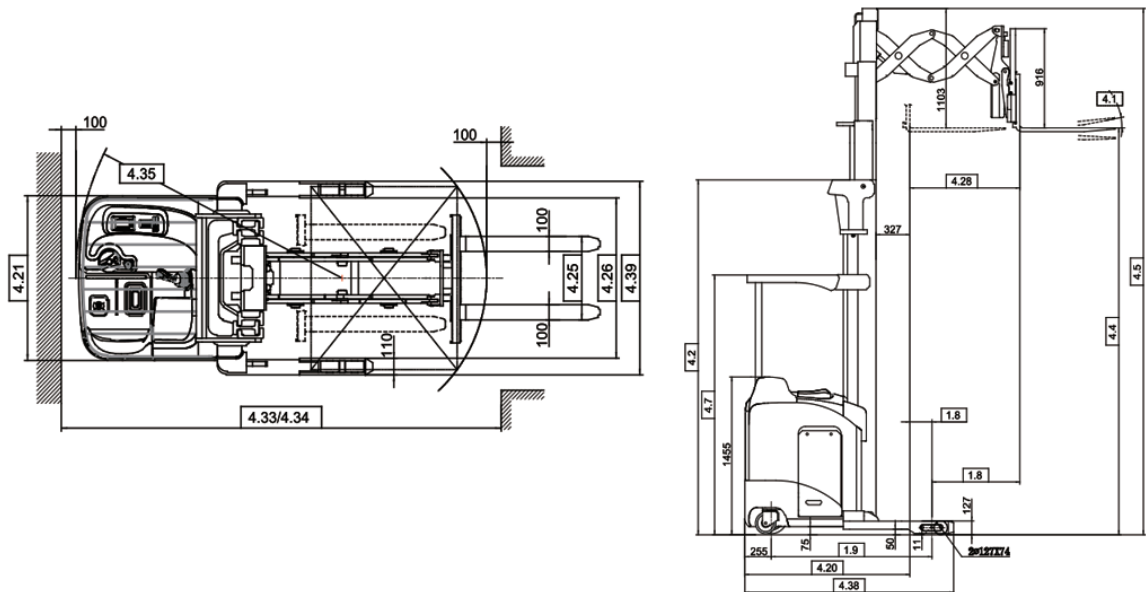

**RT44SP SINGLE SCISSOR (STAND-UP) REACH TRUCK**

Model		RT44SP			
Power		Electric	Fork Carriage Width (includes Load Backrest)	(b3) in	32.3
Operator Type		Stand	Width Across Forks (with/without side-shifter)	(b5) in	7.9 - 29.9
Load Capacity	(Q) lbs	4409	Inside Straddle	(b4) in	41.3 / 50
Load Center	(C) in	23.6	Reach (with/without side-shifter)	(l4) in	23.2
Load Distance	(X) in	12 / 10.4	Ground Clearance (Center Wheelbase)	(m2) in	2
Tires, Front (Ø x width)	in	13.5 x 5.5	Width Outrigger	(b2) in	51
Tires, Rear (Ø x width)	in	5 x 2.9	Travel Speed (Standard)	mph	5.6 / 5.9
Caster Wheel (Ø x width)	in	8 x 4	Lift Speed	fps	1.15 / 1.64
Wheels (x = driven wheels)		1 x + 1 / 4	Lower Speed	fps	1.64 / 1.64
Track Width	(b10) in	31.5	Reach Speed (Laden/Un-laden)	fps	.49 / .49
Tilt Fork Carriage (Forward / Backward)	(Angle/°)	¾	Max Gradeability (Laden)	%	5
Outrigger Height	(h8) in	4.9	Brakes	%	Electric
Overall Width	(b1) in	42.5	Traction Motor	kW	5.5
Fork Dimensions (T x L x W)	in	1.6 x 4.7 x 42.1	Lift Motors	kW	11
Fork Carriage (DIN 15173 class/form A B)		2A	Type of Controller		AC

\*Because of continual product improvements, specifications may be subject to change without notice

**SPECIFICATIONS • PERFORMANCE**

TYPE		B	C	D	E
Wheelbase	(y) in	61	61	63	65
Headlength	(lz) in	59.1	59.1	61	63
Working Aisle Width (1000 x 1200 traverse)	(Ast) in	115.9	115.9	119.3	121.3
Working Aisle Width (800 x 1200 length)	(Ast) in	118.3	118.3	120.3	122.2
Turning Radius	(Wa) in	71.9	71.9	73.8	75.8
Length over Outriggers	(lr) in	78.1	78.1	80.1	82.1
Max. Battery Size	L x W x H	14.2 x 38.6 x 30.9	16.1 x 38.6 x 30.9	16.1 x 38.6 x 30.9	19.7 x 38.6 x 30.9
Battery Voltage	V/Ah	36V/600Ah	36V/700Ah	36V/800Ah	36V/900Ah
Battery Weight	lbs	1720	1984	2260	2513

MAST MODEL		44SP177	44SP193	44SP256	44SP295	44SP334	44SP374	44SP413
Battery Pack Model	B	RT44SP4500B	RT44S4920B	RT44SP6500B	n/a	n/a	n/a	n/a
	C	RT44SP4500C	RT44SP4920C	RT44SP6500C	RT44SP7500C	n/a	n/a	n/a
	D	RT44SP4500D	RT44SP4920D	RT44SP6500D	RT44SP7500D	RT44SP8500D	n/a	n/a
	E	RT44SP4500E	RT44SP4920E	RT44SP6500E	RT44SP7500E	RT44SP8500E	RT44SP9500E	RT44SP10500E

MAST MODEL		44SP177	44SP193	44SP256	44SP295	44SP334	44SP374	44SP413
Battery Pack Model	B	8585	8708	9127	n/a	n/a	n/a	n/a
	C	8849	8973	9392	9921	9921	n/a	n/a
	D	9147	9270	9689	10218	10218	10483	n/a
	E	9423	9546	9965	10494	10494	10759	11023

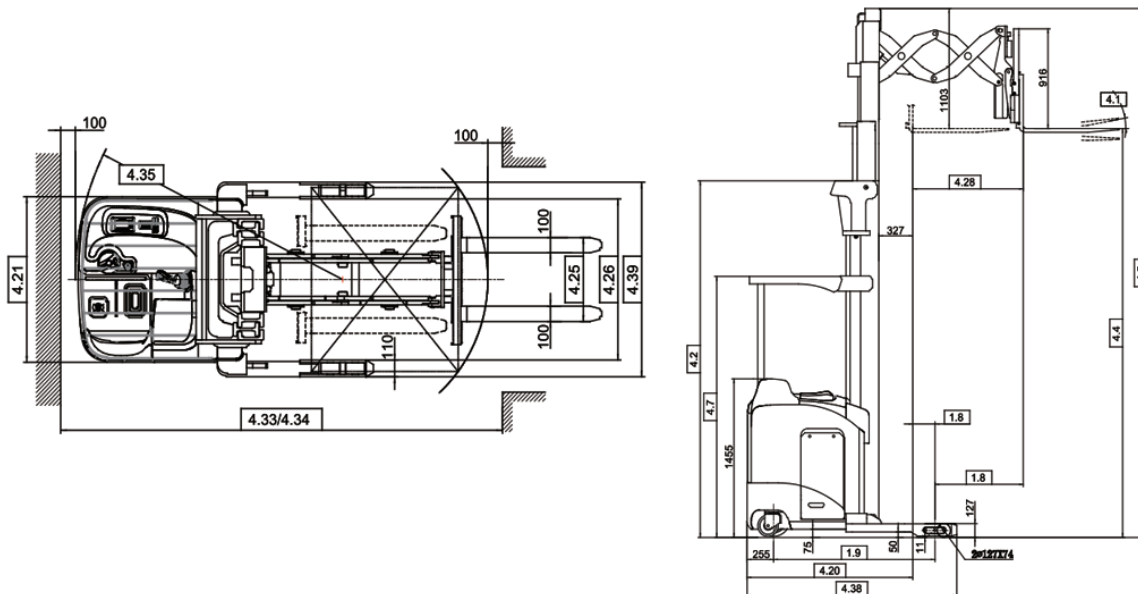

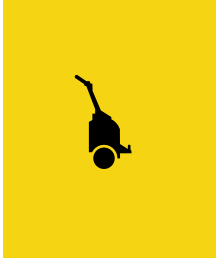

# 2200 LBS TUG22EN POWER TUG



## TUG22EN POWER TUG

The Mobile TUG22EN is a motorized tow unit ideal for pulling a variety of multiple carts in unison and in a safe manner. Designed to reduce injuries associated with repetitive pushing and pulling of heavy-laden carts, the TUG22EN is ideal for numerous industries including: healthcare, food service, hospitality and material handling sectors. The TUG22EN can be used to pull a variety of single or multiple carts in a safe and efficient manner with minimal operator effort.

### Features

- Adjustable Handle
- Curtis Electronic Controller for smooth acceleration
- Easy Battery Exchange
- External Charger
- Non-marking Solid Rubber Tires
- Stable Swivel Casters
- Deep Discharge Battery Protection

### Specifications

Max Tow Load (lbs):	2,200
Overall Length:	31.89"
Overall Width:	19.29"
Front Tires:	9.84" x 3.15"
Casters:	2.95" x 1.26"
Turning Radius:	18.7"
Travel Speed - Laden/Un-laden (km/h):	4.2 / 4.5
Battery Voltage (V/Ah):	24 / 24
Weight (lbs):	136.4



Battery Discharge Indicator



Solid Rubber Tires



Stable Swivel Casters



Battery Exchange

SKU: TUG22EN

TUG22EN POWER TUG		TUG22EN
Model		Battery
Drive		Battery
Operator Type	(Q) t	1.0 (2200 lbs)
Capacity	(Q) kg	1000 (2200 lbs)
Rated Drawbar Pull	(F) N	200 (44.96 lbs)
Wheelbase	(Y) mm	325 (12.79")
Service Weight	kg	62 (136.4 lbs)
Axle Loading (Unladen Front / Rear)	kg	46 / 16 (101.2 / 35.2 lbs)
Tires		Rubber / Polyurethane
Tire Size, Front (Ø x width)	mm	0250 x 80 (9.84" x 3.15")
Tire Size, Rear (Ø x width)	mm	075 x 32 (2.95 x 1.26")
Wheels, Number (x=driven wheels) Front / Rear		2 x / 2
Tread (Front)	(b10) mm	185 (7.28")
Tread (Rear)	(b11) mm	380 (14.96")
Handle Height (in drive position min / max)	(h14) mm	750 / 1250 (29.52" / 49.21")
Overall Length	(l1) mm	810 (31.89")
Overall Width	(b1) mm	490 (19.29")
Ground Clearance (Center of Wheelbase)	(m2) mm	38 (1.49")
Turning Radius	(Wa) mm	475 (18.7")
Travel Speed (Laden / Un-laden)	km/h	4.2 / 4.5
Drawbar Pull (Laden/Un-laden)	(N)	200/- (44.96 lbs)
Max Drawbar Pull (Laden/Un-laden)	(N)	450/- (101.16 lbs)
Service Brake		Electromagnetic
Drive Motor Rating S2 60 min	kW	.3
Battery acc. to DIN 43531/35/36 A,B,C, no		No
Battery Voltage / Nominal Capacity K5	V/Ah	24 / 24
Battery Weight	kg	16 (35.2 lbs)
Type of Drive Control		Dc Speed Control
Sound Level (at driver's ear acc. to EN 12053)	dB(A)	<69

\*Because of continual product improvements, specifications may be subject to change without notice

**HITCH OPTIONS**

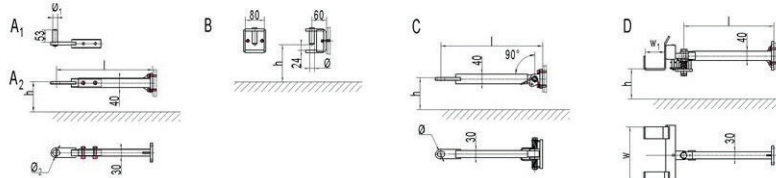
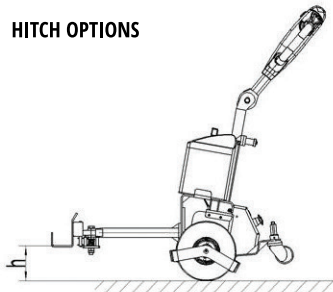

Type A: Ø<sub>1</sub> = 20mm (0.78") | Ø<sub>2</sub> = 25mm (0.98") • H = 148 ~ 268mm (5.82" ~ 10.55") • L = 402.5mm (15.84")  
 Type B: Ø = 20mm (0.78") • H = 96 ~ 276mm (3.78" ~ 10.86")  
 Type C: Ø = 25mm (0.98") • H = 148 ~ 268mm (5.82" ~ 10.55") • L = 424.5mm (16.71")  
 Type D: W<sub>1</sub> = 80mm (3.15") • W = 240mm (9.45") • H = 88 ~ 208mm (3.46" ~ 8.19") • L = 375mm (14.76")

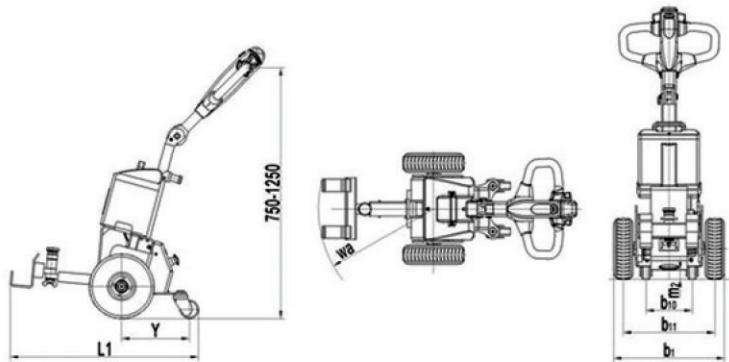

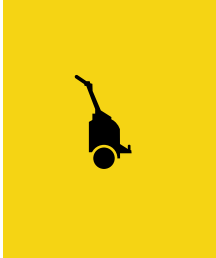

**1500 LBS**  
**TUG15**   
**POWER TUG**



**TUG15 POWER TUG**

The Mobile TUG15 is a motorized tow unit ideal for pulling a variety of multiple carts in unison and in a safe manner. Designed to reduce injuries associated with repetitive pushing and pulling of heavy-laden carts, the TUG15 is ideal for numerous industries including: healthcare, food service, hospitality and material handling sectors. The TUG15 can be used to pull a variety of single or multiple carts in a safe and efficient manner with minimal operator effort.

**Features**

- Non-Marking Flat-Free Tires
- Quick Change Battery System
- Self-Diagnostics-Enables, 125Amp Controller
- User Interface Hand Controller (Horn, Key Switch, Lift Button, Throttle, 2-Speed Switch)
- Built-In Battery Charger
- Battery Indicator
- Durable ABS Shroud
- Travel Wheel (for use when not transporting load)
- Rain-Proof (IP-54 Rating)
- Pin Configuration Hitch Docking (for use on many carts)

**Specifications**

Max Tow Load (lbs):	1,500
Overall Length:	18.75"
Overall Width:	24"
Overall Height:	41.6"
Wheels:	8.75"
Transaxle Drive (V):	24 DC
Lift Motor/Actuator (V):	24 DC (IP-66 rated)
Battery (Ah):	(x2) 22 AGM (Sealed Lead Acid)
Shipping Size (cubic ft):	21
Shipping Weight (lbs):	150



Console



Handle/Steering Assembly

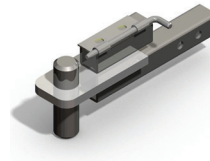

Male Hitch

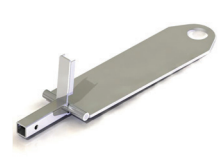

Female Hitch

SKU: TUG15

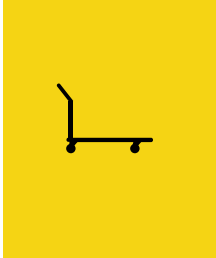

# 1500 LBS MPC MOTORIZED CART



## MPC MOTORIZED PLATFORM CART

The Mobile MPC is an ergonomic and efficient tool designed for transporting heavy or awkward loads. Available in 3 different platform sizes, you can bolt, weld, or clamp your current equipment and transport carts to the steel platform to create your own custom cart.

### Features

- Proportional Speed Control (2 Speeds)
- LED Battery Charge Indicator
- Emergency Stop Switch
- Maintenance-Free Transaxle Drive Switch
- Dynamic Regenerative Braking
- Automatic Electro-Mechanical Parking Brake
- Intuitive Fingertip Motion Controls (Top: Forward, Bottom: Reverse)
- Rugged Spring Suspension System w/Center Wheel Drive
- Built-In Battery Charger w/Power Cord
- Reinforced Tubular Steel Frame
- Solid-State Electronic Module w/24V Power System
- Water Resistant Electronics
- Fail Safe Throttle Design
- Flat-Free Tires and Casters

### Specifications

Capacity (lbs):	1,500 (1,000 on 6 degree slope)
Platform Lengths:	41" / 48" / 68.5"
Overall Width:	27"
Overall Length:	50" / 56.5" / 60"
Overall Height:	42.5"
Power Wheels:	8.75"
Swivel Casters:	5"
Shipping Size (cubic ft):	47.6 / 56.6
Shipping Weight (lbs):	265 / 270 / 292



Profile View



Front View

SKU: MPC2741, MPC2745, MPC2760





# STORE FIXTURES

Selecting The Right Ladder	112	Outdoor Safety Gate <b>ASGN-OD</b>	120
Rolling Ladder <b>TILT &amp; ROLL</b>	113	Indoor Safety Gate <b>ASGN / HASG3812</b>	121
Rolling Ladder <b>RL-50</b>	114	Safety Work Platform <b>SWP</b>	122
Rolling Ladder <b>RL-60</b>	115	Nestable Shelf Cart <b>MNSC2853</b>	123
Platform Truck <b>TILT</b>	116	Aluminum Hand Truck <b>HT1766</b>	124
Upright Lumber Cart <b>LTC3060</b>	117	Pail Lifter <b>MPL200</b>	125
Steel Lumber Cart <b>LC3060</b>	118	Shopping Cart <b>ESC-XTI</b>	126
Siding Cart <b>SC3696</b>	119	Floor Jack <b>EFJ88</b>	127
Storage T-Rack <b>ST6054</b>	119		



**LADDERS / PLATFORM TRUCKS / LUMBER CARTS / SIDING CARTS / STORAGE RACK  
WORK PLATFORM / SAFETY GATES / APPLIANCE HAND TRUCK / PAIL LIFTER  
ELECTRIC SHOPPING CART / FLOOR JACKS**

# SELECTING THE RIGHT LADDER

One of the most common mistakes made in ordering many ladders is getting them too large for the available workspace. Here are some things to consider before ordering a new ladder:

## 1. LADDER DIMENSIONS

### Base Width

Is very important because as ladders get taller, the base width increases. It is important to be sure that the ladder will not be too wide for your workspace. We offer different tread widths to accommodate most work areas.



### Base Length

Is the measurement of how long the base of the ladder runs. This is dependent upon the height of the ladder. The taller the ladder, the longer the base. Also, lower climb angles also increase base length.

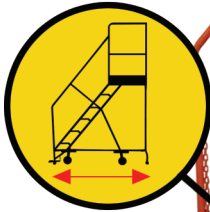

### Working Height

Is the approximate height that you would like to be able to comfortably reach. It is usually calculated at 5.5" above the ladder's platform height.



### Overall Height

Is VERY important. You want to be sure that your ladder will not be too tall to fit into your workspace. This includes being able to fit through any doors that you may need to move it through, or under any ceilings or fixtures that you may have.



### Top Step Height

Is the measurement of the top step from the ground. It's important that this measurement is not too far above or below your desired working height.



## 2. CLIMBING ANGLE

Mobile offers 2 climbing angles in our 'RL' Rolling Ladder Series. 60° is standard and the 50° climbing angle makes carrying items up and down the ladder easier.



### 60° CLIMBING ANGLE

Standard Models:

RL6-60 · RL8-60 · RL10-60

Capacity:

350 lb

Operator must go up and down facing same direction (always facing stairs)



### 50° CLIMBING ANGLE

Standard Models:

RL6-50 · RL8-50 · RL10-50 · RL14-50

Capacity:

350 lb

Operator goes up and down just like a staircase, facing their direction of travel

## 3. COLOUR OPTIONS

Mobile offers a variety of powder-coated colours to suit your needs. Choose from any of the following colours:

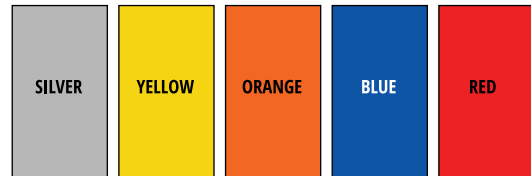

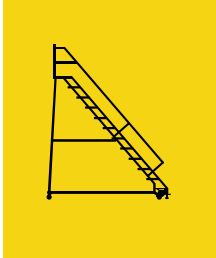

**350 LBS**

# TILT & ROLL

## ROLLING LADDER



### TILT & ROLL ROLLING LADDER

Mobile Rolling Ladders are compact, high reach, highly safe ladders. Steel construction, non-slip surfacing, rubber feet, a braking mechanism and 42" handrails are included as standard, ensuring optimal operator safety. Swivel casters and center pivot wheels allows for smooth transport and easy maneuverability.

#### Features

- 14 Gauge Steel Construction
- 1.25" Diameter Tubing
- Non-Slip Steps/Platform
- Polyurethane Wheels
- Rubber Feet for Stability
- High-Quality Powder Coat Finish

Specifications	Model# RL3-TR	Model# RL4-TR
Step Count	3	4
Height to Top Step	29"	36"
Platform Size	24"W x 22.5"L	
Caster Size	1.5" x 5" (2 Fixed)	
Handrail Height	30"	
Climbing Angle	50 Degrees	
Weight (lbs)	74	84

**Steps Available: 3, 4**

**Colours Available: Orange, Red, Yellow, Blue, Grey**

**Options: 60 Degree**



Rubber Stabilizers



Polyurethane Wheels

SKU: RL3-TR, RL4-TR

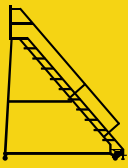

# TURN-IN-PLACE RL-50 ROLLING LADDER



Shipping Position

### Features

- Fixed Link Trip Step Assembly
- 1 1/4" Steel Tubing throughout
- Uniquely Designed Trip Step
- Non-Slip Perforated Step Design
- Inspection Sheet/Paper Holder
- Rubber Feet for Stability
- Easy After-Market Maintenance
- Wide Top Platform
- Reinforced Cable-less Design
- 6" Kick-Plate on Top Platform
- Powder Coat Paint Finish
- Meets OSHA and ANSI A14.7 requirements
- Easy Climbing Angles
- Center Pivot Wheels for Quick, On-The-Spot Maneuverability



Safety Chain



Rubber Feet

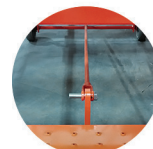

Trip-Step Assembly



Wheels



Casters



Floor Lock

## RL-50 SERIES 50 DEGREE TURN-IN-PLACE ROLLING LADDER

Mobile Rolling Ladders are compact, high reach, highly safe ladders. Steel construction, non-slip surfacing, rubber feet, a braking mechanism and 42" handrails are included as standard, ensuring optimal operator safety. Swivel casters allows for smooth transport, and center pivot wheels allows for time-saving, 'on-the-spot' maneuverability.

Steps Available: 6, 8, 10, 14

Colours Available: Orange, Red, Yellow, Blue, Grey

Specifications	Model# RL6-50	Model# RL8-50	Model# RL10-50	Model# RL14-50
Step Count	6	8	10	14
Height to Top Step	60"	80"	100"	140"
Platform Size	24"W x 27.5"L			
Caster Size	2.7" x 7" (2 Fixed) • 1.5" x 5" (2 Swivel)			
Handrail Height	42"			
Climbing Angle	50 Degrees			
Weight (lbs)	190	220	250	310

SKU: RL6-50, RL8-50, RL10-50, RL14-50

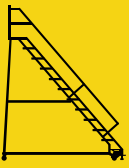

# 60 DEGREE RL-60 ROLLING LADDER



Shipping Position

### Features

- Fixed Link Trip Step Assembly
- 1 1/4" Steel Tubing throughout
- Uniquely Designed Trip Step
- Non-Slip Perforated Step Design
- Inspection Sheet/Paper Holder
- Rubber Feet for Stability
- Easy After-Market Maintenance
- Wide Top Platform
- 6" Kick-Plate on Top Platform
- Powder Coat Paint Finish
- Meets OSHA and ANSI A14.7 requirements



Safety Chain



Rubber Feet



Casters



Floor Lock

Steps Available: 6, 8, 10

Colours Available: Orange, Red, Yellow, Blue, Grey

## RL-60 SERIES 60 DEGREE ROLLING LADDER

Mobile Rolling Ladders are compact, high reach, highly safe ladders. Steel construction, non-slip surfacing, rubber feet, a braking mechanism and 42" handrails are included as standard, ensuring optimal operator safety. Swivel casters allows for smooth transport, and easy maneuverability.

Specifications	Model# RL6-60	Model# RL8-60	Model# RL10-60
Step Count	6	8	10
Height to Top Step	56"	73"	90"
Platform Size	24"W x 23"L		
Caster Size	1.5" x 5" (2 Swivel / 2 Fixed)		
Handrail Height	42"		
Climbing Angle	60 Degrees		
Weight (lbs)	155	175	195

SKU: RL6-60, RL8-60, RL10-60



**2500 LBS**

# PLATFORM TILT TRUCK



**Features**

- Rigid Plastic Bed on Steel Frame
- Steel Handle
- Swivel/Fixed Casters

Specifications	Model# TT3060	Model# TT2448
Bed Capacity (lbs):	2,500	2,000
Platform Height:	10"	
Platform Size:	30" x 60"	24" x 48"
Casters (Swivel/Fixed):	2" x 6" (4 / 2)	2" x 6" (2 / 2)
Handle Height:	24"	
Weight (lbs):	98	56

**Styles Available (Volume Quantities ONLY):**

- Steel Bed (SPT2448 / SPT3060)
- Aluminum Bed (APT2448 / APT3060)



Handle Tubing



Handle



Swivel Caster



Shipping Bundle

**PLATFORM TILT TRUCK**

Mobile's Platform Tilt Trucks are designed so that operators of all physical types can easily use. Large, mixed or stackable loads can fit on the large 30" x 60" platform and swivel and fixed casters allows for smooth transport and easy maneuverability.

SKU: TT3060, TT2448, SPT2448, SPT3060, APT2448, APT3060



# 2000 LBS LTC3060 UPRIGHT LUMBER CART



Model: LTC3060-II

## LTC3060 UPRIGHT LUMBER CART

The Mobile LTC3060 Upright Lumber Cart is designed at optimal ergonomic specifications so that operators of all physical types can easily use. Upright rails support mixed load sizes and swivel and fixed casters allows for smooth transport and easy maneuverability.

### Features

- Rigid Plastic Bed, Steel Bed (Model#: LTC3060-II)
- Steel Support Rails
- Swivel/Fixed Casters
- Powder Coat Paint Finish (Model#: LTC3060-II)
- E-Coating Steel Finish (Model#: LTC3060-II)

Specifications	Model# LTC3060	Model# LTC3060-II
Bed Capacity (lbs):	2,000	
Platform Height:	11.5"	11.6"
Bed Size:	30" x 60"	
Bed Material:	Plastic	Steel
Casters (Swivel/Fixed):	2" x 6" (4 / 2)	
Weight (lbs):	138	

### Models Available:

- LTC3060
- LTC3060-II
- MCC
- OCLC



Steel Support Rails



Casters



Model: MCC



Model: OCLC

SKU: LTC3060, LTC3060-II, MCC, OCLC

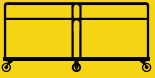

# 2000/2500 LBS LC3060 STEEL LUMBER CART

## Features

- Steel Construction
- Collapsing Load Guide Bars
- Swivel/Fixed Casters



Model: LC3272

Specifications	Model# LC3060	Model# LC3272
Capacity (lbs):	2,000	2,500
Top Rack Area:	30" x 60"	32" x 72"
Top Rack Height:	30"	
Bottom Rack Area:	27" x 41"	29.5" x 53"
Bottom Rack Height:	9.75"	
Casters (Swivel/Fixed):	2" x 6" (4 / 2)	
Weight (lbs):	138	120



Casters



Steel Construction

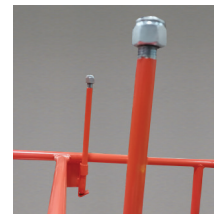

Collapsing Load Guide Bars

## LC3060 STEEL LUMBER CART

The Mobile LC3060 Lumber Cart is designed at optimal ergonomic specifications so that operators of all physical types can easily use. Swivel and fixed casters allows for smooth transport and easy maneuverability.

SKU: LC3060, LC3272



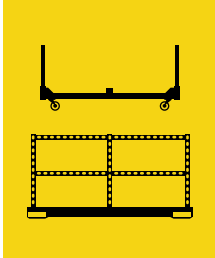

## 2500 LBS SC3696 SIDING CART

### Features

- Heavy Duty Steel Construction
- Powder Coat Paint Finish
- Swivel Casters

Specifications	Model# SC3678	Model# SC3696
Capacity (lbs):	2,500	
Dimensions:	36" x 48" x 40"	36" x 96" x 40"
Casters (Swivel):	2" x 6"	
Weight (lbs):	200	350

SKU: SC3678, SC3696

### SC3696 SIDING CART

The Mobile SC3696 Siding Cart is a versatile transport unit designed for moving large or awkward bundle loads. Heavy duty steel construction can withstand punishing wear and tear and the swivel casters ensures easy maneuverability during transport.



## 2000 LBS ST6054 STORAGE T-RACK



### Features

- Removeable Center Rack w/Lock-In Capability
- 7" Fork Pockets for Pallet Truck Entry and for easy transport
- Carpeted Load Surface



Options: Swivel Casters

### ST6054 STORAGE T-RACK

The Mobile ST6054 Storage T-Rack is a versatile piece of equipment that can accommodate large, long, or awkward load storage. Make it portable and increase traffic efficiency with 7" pockets that allows for pallet truck entry and transport.

SKU: ST6054

### Specifications

Capacity (lbs): 2000	Dimensions: 60" x 96" x 54"	Fork Pockets: 7"	Weight (lbs): 500
----------------------	-----------------------------	------------------	-------------------

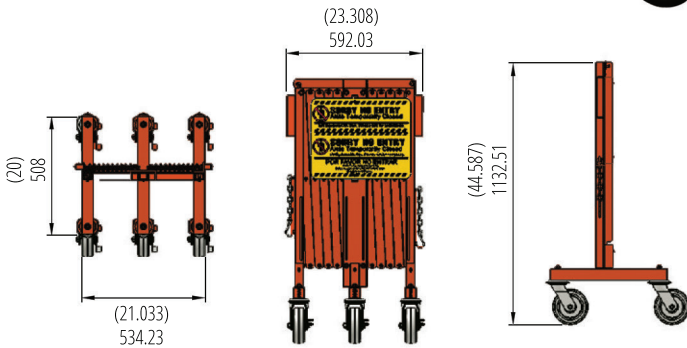

## OUTDOOR SAFETY GATE ASGN-OD ALUMINUM

### Features

- Large Non-Slip Rubber Tires (ideal for travel over ice/snow uneven surfaces)
- Heavy Duty Latch Bar (withstands High usage environments, will not bend/break)
- Pantograph Slats and heavier overall weight allow for reduced air friction and decreased blow over accidents
- Dual Handle Design eliminates pinch points
- Compact Accordion Design makes storage easier
- Easy set up/take down
- State-of-the-Art German Casters with both Rolling/Swivel Lock ensures gate will not roll away even if on a slope or in windy conditions

### Specifications

Collapsed Length:	23.3"
Overall Width:	20"
Overall Height:	44.5"
Aluminum Slat Thickness:	4.88"
Steel Gauge:	11GA
Weight (lbs):	N/A

### ASGN-OD OUTDOOR SAFETY GATE

Mobile's Aluminum Safety Gate provides users with a safe and efficient means of prohibiting traffic. Each Aluminum Safety Gate can be permanently and safely fastened, allowing the user to quickly restrict access should the need arise.

#### Caster Specifications

Wheel Ø:	160mm
Wheel Width:	40mm
Load Capacity:	135kg
Temperature Resistance to:	-20° C
Temperature Resistance to:	60° C
Tread and Tire Hardness:	80° Shore A



Collapsed View



Dual Handles



Non-Slip Solid Rubber Casters

SKU: ASGN-OD



#### Caster Features

- Bracket: Pressed steel, with double ball bearing in the swivel head, strong central kingpin, ball protection by the special top plate and ball disc design. The special dynamic riveting process of the swivel head results in minimal swivel head play and smooth rolling characteristics with an increased service life achieved by the work hardening of the ball race grooves.
- Wheels: standard solid rubber, very high operational comfort, low-noise operation, very good floor preservation
- Tread/Tire: Made of standard solid rubber.
- Wheel Center/Rim: high-quality, impact-resistant polypropylene. Pressed-on tire.



## INDOOR SAFETY GATE

# ASGN/HASG



## ALUMINUM



ASGN

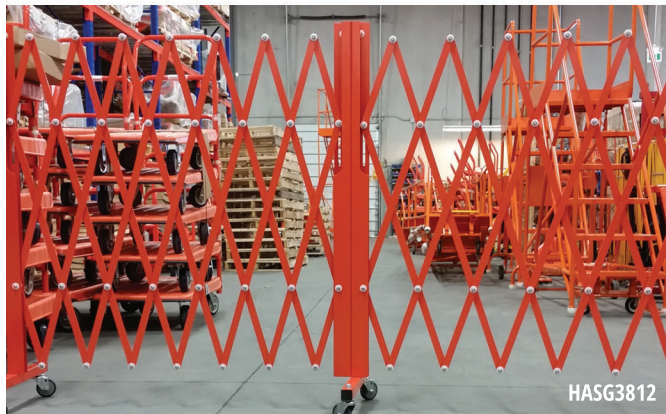

HASG3812

### INDOOR SAFETY GATE

Mobile's Aluminum Safety Gates provide users with a safe and efficient means of informing customers that an aisle is temporarily closed. Model#: ASGN can be permanently and safely secured to a store aisle, allowing the user to quickly restrict access should the need arise.

#### Features

- Heavy Duty Aluminum Construction
- High-Quality Powder Coat Finish
- Permanently secured for quick aisle restriction (ASGN ONLY)
- Closes to a mere 16.75" width for easy storage (ASGN ONLY)
- Expands in seconds
- Warning Sign available in English/French or English/Spanish

Specifications	Model# ASGN	Model# HASG3812
Expanded Gate Height:	36"	45"
Post Height:	57.5"	54.75"
Collapsed Length:	16.75"	38"
Expanded Length:	153"	288"
Width:	3"	20"
Casters:	2"	3" (6)
Weight (lbs):	45	66

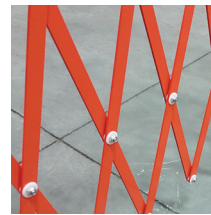

Aluminum Construction

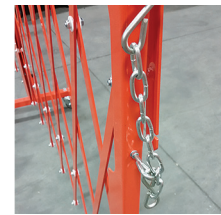

Locking Chain



Swivel Casters

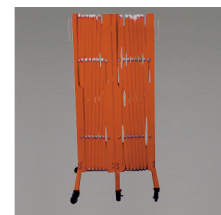

Collapsed (Model#: HASG3812)

SKU: ASGN, HASG3812



## SAFETY SWP WORK PLATFORM

### Features

- Swinging/Lockable Gate
- Safety Chain to secure to carriage
- All Welded, Heavy Duty Construction
- Powder Coat Paint Finish

### Specifications

Overall Width:	32"
Overall Length:	48"
Overall Back Screen Height:	72"
Overall Guardrail Height:	42"
Fork Pockets:	7" x 3"
Casters:	6"



Front View



Back View

### SWP SAFETY WORK PLATFORM

Available for most of the standard Mobile adjustable fork hydraulic stackers. The safety cage is designed to safely lift the operator, or another person in high-reach applications such as ceiling light changing, shelf-stocking, etc. It comes with a safety chain for easy exit and entry (an optional hinged, locking door is also available. Comes complete w/railings and carriage safety chains.

SKU: SWP



# 1000 LBS MNSC2853 NESTABLE SHELF CART

## Features

- Heavy Duty All Steel Construction
- Powder Coated Silver
- Foldable Lockable Shelves
- Nestable Folding Design for Easy Storage
- Document Holder
- Easy Access (Folding) Cardboard Holder
- (2) each 5" x 2" Poly Rigid and Swivel Casters

## Specifications

Capacity (lbs):	1,000 (500 per shelf)
Dimensions (W x D x H):	60" x 30" x 71"
Packaging:	Non Pallet (Nestable)
Nesting Dimensions (L x D x H):	70.4" x 47.25" x 71" (3 carts per)
Carts Per 40' HQ Container:	74
Weight (lbs):	242

## MNSC2853 NESTABLE SHELF CART

A simple and innovative solution to move inventory from warehouse to store shelves. Each cart can hold up to 1,000lbs (500lbs per shelf) of product and makes transferring inventory from backroom to sales floor a simple task. Each cart occupies minimum floor space, and assists in avoiding the need to store overstock on bulky pallets. Nestable in storage.

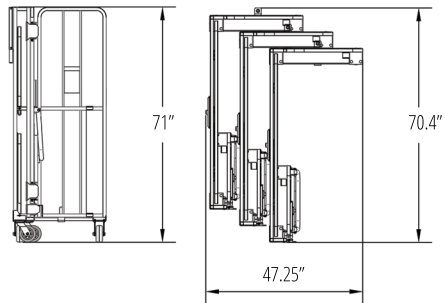

## Options: Linkable with Other Carts • Tow Hitch • Shelf Dividers (Foldable)



Hitch



Nestable (Folded) View



Pull Hitch



Caster



Easy Folding Partitions

SKU: MNSC2853



# 1200 LBS HT1766 APPLIANCE HAND TRUCK



## Features

- Double Loop Handle
- Appliance Belt and Crank
- Cushioned Rails to protect loads from scratches

## Specifications

Capacity (lbs):	1,200
Frame Width:	17"
Frame Height:	66"
Frame Depth:	8"
Noseplate:	5.25" x 24"
Wheels:	2" x 8"
Weight (lbs):	70

## HT1766 APPLIANCE HAND TRUCK

The Mobile HT1766 Appliance Hand Truck's solid construction is able to endure punishment from large, bulky and awkward loads. Strap and tension bars secures and stabilizes loads during transport on uneven surfaces, over rough terrains, or up and down stairs.



Load Straps



Platform



Wheel



Stabilizers

SKU: HT1766



# 5-GALLON MPL200 PAIL-LIFTER

## Features

- Operates in narrow aisles/congested areas
- Picks pails from floor or pallets
- Can be used to load tinters, shakers, vehicles
- Moves easily on any surface (indoors or out)
- Portable/lightweight
- Fits easily in any van/truck
- Unit is free-standing even when loaded and raised
- Lift Controls are mounted to handle for easy use
- Pail Retainer clips hold pails steady during transport

## Specifications

Capacity (lbs):	200
Lift Carriage Travel:	37"
Under Pail Clearance:	35"
Overall Height (Lowered/Raised):	52" / 82"
Lifting Controls:	Thumb Switch
Wheels:	8" Solid
Battery (V/Ah):	24 / 7.2 (Lead Acid)
Charger (V):	110
Ship Weight (lbs):	125

## MPL200 5-GALLON PAIL-LIFTER

Mobile's MPL200 Pail-Lifter is as easy to use as any two-wheel hand truck, but offers even greater convenience. Designed specifically for handling 5-gallon pails of paint and other construction materials, it features a unique lifting yoke that securely supports pails during transport. Thumb operated lifting controls are placed on the handle for easy access. Pails can be raised to an under clearance height of 35". By eliminating manual lifting, the risk of injury/repetitive stress disorders is significantly reduced.

### Shipping Info:

Freight Class: 175 • Freight Orientation: Upright  
 Ship Dimensions: 36"W x 48"L x 62.25"H (approx.) with recommended packaging  
 Ship Weight: 170lbs (approx.) with recommended packaging

SKU: MPL200

## Options: Linkable with Other Carts • Tow Hitch • Shelf Dividers (Foldable)



Pail Retainer (keeps loads secure)



Optional Platform (for case-packed goods)



Lifting Yoke holds pails in place

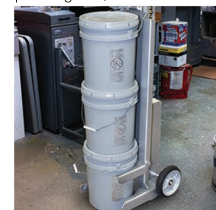

Safely handles 3 pails simultaneously

Machine Dimensions Without Packaging (approx.): 20"W x 20"L x 58.75"H • Machine Weight Without Packaging (approx.): 125lbs  
 Default Rise Time: 10 seconds (37.375" vertical travel) • Lifting Speed: 4" per second • Batteries (Maintenance-Free, Sealed Lead Acid): (2) 12V/7Ah  
 Frame (Aluminum) Dimensions: 52"H x 30"D x 20"W  
**\*\*\* FOR USE ONLY WITH 5 GALLON LATEX PLASTIC PAILS. NOT FOR USE WITH METAL PAILS. MACHINE IS NON-RETURNABLE \*\*\***



# 750 LBS ESC-XTI SHOPPING CART



## ESC-XTI 'GREEN' ELECTRIC SHOPPING CART

The Mobile ESC-XTI provides the ultimate in ergonomic design and is built with operator comfort and safety sensibilities. Seat features lumbar support for the rider's back; padded arm rests for comfort; a seat switch; and thumb activated wig-wag controls. The stable platform features a flat, gripping deck from which riders can stand to reach shelf items, and moulded foot rests provide both leg rests and straight leg extension. The unit 'turns-on-a-dime' making narrow aisle maneuvering easier than ever. It will fully turn within the length of the cart itself and need less than 5 feet to complete a 180 degree turn. Combining strength and functionally, the unit features a sturdy steel frame, a single battery that runs longer between charges, and a 4-stage charger that can be left plugged without damaging the battery. Motor is energy efficient and power usage is minimized to only 3 amps = up to 22 hours of operation between charges. Front wheel comes with a unique drive hub motor, literally a motor within a wheel.

**CARBON FOOTPRINT:** Environmental impact is greatly minimized with a finished powder coat paint (available in many colours) and PVC FREE construction making it the first 100% Recyclable Electric Cart.

### Features

- Exclusive Hub Motor drive system: 1/4 HP continuous
- 1/2 Peak Regenerative/Dynamic Braking
- Single 12V / 35Ah Battery
- 3 Amp, 4 Stage Smart Charger
- Exclusive Intelli-Charge Battery Monitoring system
- 6' coiled Charging Cord
- Heavy Duty 18" PVC FREE Seat
- Exclusive Wag-Flag controls
- 1" Tube 16 guage steel Frame
- Emergency Stop Switch
- Anti-Tip Swivel Casters
- Horn & Reverse Warning Beeper
- 3 Manual Reset Circuit Breakers
- Low Charge Indicator
- Battery reverse polarity protection
- Keyed or Keyless Operation
- Fixture Height Rear Bumper
- Full Length Basket Bumper

### Specifications

Capacity (lbs):	750
Rider Capacity (lbs):	550
Basket Capacity (lbs):	200
Basket Size (W x L x H):	24" x 20" x 15"
Turning Radius:	31.5"
Tires (Rubber):	8" (Solid) Non-Marking
Forward Speed (mph):	2.1
Reverse Speed (mph):	1
Continuous Run Times (hrs):	10
Shopping Run Time (hrs):	20

SKU: ESC-XTI



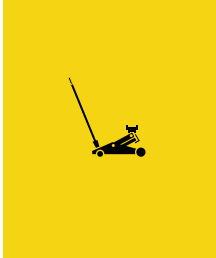

8000/10000 LBS

# EFJ88



## FLOOR JACK

### Features

- Heavy Duty Steel Construction
- Floor Slide



EFJ88

EFJ88-P

Specifications	Model# EFJ88	Model# EFJ88-P
Capacity (lbs):	8,000	10,000
Lowered Height:	2.5"	
Raised Height:	15"	17"
Removable Handle:	22"	33"
Rear Steel Wheels:	3"	
Weight (lbs):	65	68

### EFJ88 FLOOR JACK

The Mobile EFJ88 Floorlift Jack can lift up to 8,000 or 10,000 lbs, is lightweight, easy-to-use and allows for easy movement and storage.

SKU: EFJ88, EFJ88-P

# MOBILE

# SERVICE & SUPPORT

## Efficient/Friendly Service

Outstanding support whether it be pre, during, or post-purchase, is a crucial component of Mobile's commitment to YOU. Our knowledgeable service team is dedicated in providing you with best practices and solutions for managing your material handling equipment fleet.

No matter the request, we will do whatever it takes.



## Parts

To keep your equipment investment running at peak performance, we recommend using OEM parts certified by Mobile. We maintain a complete parts inventory for all Mobile and ECO product lines, including legacy and discontinued models. Service bulletins, operating instructions, and parts information are also available.

For legacy and or discontinued models, we recommend you speak to a Mobile Live Agent for support.

**LIVE PARTS AGENT SUPPORT (North America): 8AM-4:30PM EST | MON-FRI**



## Warranty

Mobile stands behind our equipment with one of the most comprehensive warranties in the Industry. We offer equipment with premium components and quality sourced materials, in order to ensure continuous operation and negligible equipment down-time. In the event of a system malfunction or part failure, Mobile will assist you in registering your unit, and explaining coverage contained within the warranty.

For detailed product specific warranty information, please visit the warranty page of our website at: [mobilept.com/warranty](http://mobilept.com/warranty)



**Quick Ship Equipment Available. Ask for further details.**

**LIVE AGENT SUPPORT (North America): 8AM-4:30PM EST | MON-FRI**



 **Global Headquarters** Mississauga, Ontario, Canada

 **Dealer Network & DC Facilities**

**U.S.A.:**

Agawam MA • Charlottle NC • Schiller Park IL • Fort Worth, TX

**South America:**

PERU: Lima

**Europe:**

IRELAND: Dublin • Galway

UK: Peterborough

SPAIN: Murcia • Cartagena • Barcelona

BELGIUM: Brussels

NETHERLANDS: Waalwijk • Rotterdam

POLAND: Warsaw • Krakow

CYPRUS: Latsia

HUNGARY: Budapest

CZECH REPUBLIC: Prague

TURKEY: Istanbul

**Middle East:**

UNITED ARAB EMIRATES: Dubai

**South Asia:**

PHILLIPINES: Davao City



# INDEX

## PAGE # PALLET TRUCKS

- 6-7 Premium **MLX55**
- 8 Economy **ECO I-55**
- 9 Entry Level **IBT55**
- 10 Heavy Duty **ECO I-77**
- 11 Heavy Duty **ECO I-11HD**
- 12 Galvanized **ECO I-55G**
- 13 Stainless Steel **ECO I-55SS**
- 14 Low Profile **MINI**
- 15 4-Way **MINEY**
- 16 Super Low Profile **MO**
- 17 Weigh Scale **ECO I-44WL**
- 18 Roll Truck **ECO ERT**
- 19 Rough Terrain **ECO RTT**
- 20 Auto Brake **ECO I-55A**

## 22-23 POWER DRIVE

### SCISSOR LIFTS

- 26 Manual **ECO EMSL22N**
- 27 Manual **ECO EMSL33N**
- 28 Stainless Steel **ECO EMSL22N-SS**
- 29 Stainless Steel **ECO EMSL33N-SS**
- 30 Battery **ECO EBSL22N**
- 31 Battery Stainless Steel **ECO EBSL22N-SS**
- 33 Battery **ECO EBSL33N**
- 34 Manual **MPS25**
- 35 Battery **BPS25**

### LIFT TABLES

- 38-39 Foot Pump **ECO ELT SERIES**
- 40 Stainless Steel **ELTSS**
- 41 Electric **ECO EELT770**

### STACKERS

- 44 Semi-Electric **B-Series**
- 47 Telescopic **F-Series**
- 48-49 Electric Platform **EEP88**
- 50 Manual Platform **EMP88**
- 51 Manual Winch **MW500**
- 52 Manual Winch **MW750**
- 53 Manual Pump **EMS22N**
- 54 Manual Pump **EMS22NFF**
- 55 Fixed Platform **EMS22NFP**
- 56 Self-Lifting **ESLS11**
- 57 Adjustable Fork **EHS22N**
- 58 Fixed Fork **EHS22FFN**
- 59 Fork-Over **EHS33FFN**

## PAGE # CUSTOM STACKERS

- 62 Folding Mast **B76CFP-FM**
- 63 Folding Mast w/Basket **B65CFP-FMB**
- 64 Fixed Straddle Legs **FTAF173**
- 65 On-Board Tote **OBST500**

### SELF-PROPELLED

- 68-69 Semi-Electric Pallet Truck **ESET26P**
- 70-71 Full Electric Pallet Truck **EFET33N**
- 72-73 Full Electric Lithium Powered Pallet Truck **EFET33N-LB**
- 74-75 Full Electric Lithium Powered Pallet Truck **EFET44N-LB**
- 76-77 Electric Scale Pallet Truck **EFET33N-LB-SC**
- 78-79 Weigh Scale Pallet Truck **EFET33SC**
- 80-81 Ride-On Pallet Truck **ESPT44-55RN**
- 82-83 Long Handle Pallet Truck **ESPT44WLH**
- 84-85 Heavy Duty Pallet Truck **HESPTN**
- 86-87 Low Lift Electric Pallet Truck **ESPT44-LL**
- 88-89 Low Lift Straddle Stacker **LLS26NU**
- 90-91 Low Lift Fork-Over Stacker **LLS26FFNU**
- 92-93 Walkie Long Handle Stacker **APSWLH-SL**
- 94-95 Heavy Duty Stacker **APSFN SERIES**
- 96-97 Dual Lifting Stacker **APS35DFFN**
- 98-99 Counter Balance Stacker **CBS28N**
- 100-101 Counter Balance Stacker **CBSN SERIES**
- 102-105 Stand-Up Reach Stacker **RT33SP / RT33DP / RT44SP**
- 106-107 Power Tug **TUG22EN**
- 108 Power Tug **TUG15**
- 109 Motorized Platform Cart **MPC**

### STORE FIXTURES

- 113 Rolling Ladder **TILT & ROLL**
- 114 Rolling Ladder **RL-50**
- 115 Rolling Ladder **RL-60**
- 116 Platform Truck **TILT**
- 117 Upright Lumber Cart **LTC3060**
- 118 Steel Lumber Cart **LC3060**
- 119 Siding Cart **SC3696**
- 119 Storage T-Rack **ST6054**
- 120 Outdoor Safety Gate **ASGN-OD**
- 121 Indoor Safety Gate **ASGN / HASG3812**
- 122 Safety Work Platform **SWP**
- 123 Nestable Shelf Cart **MNSC2853**
- 124 Aluminum Hand Truck **HT1766**
- 125 Pail Lifter **MPL200**
- 126 Shopping Cart **ESC-XTI**
- 127 Floor Jack **EFJ88**

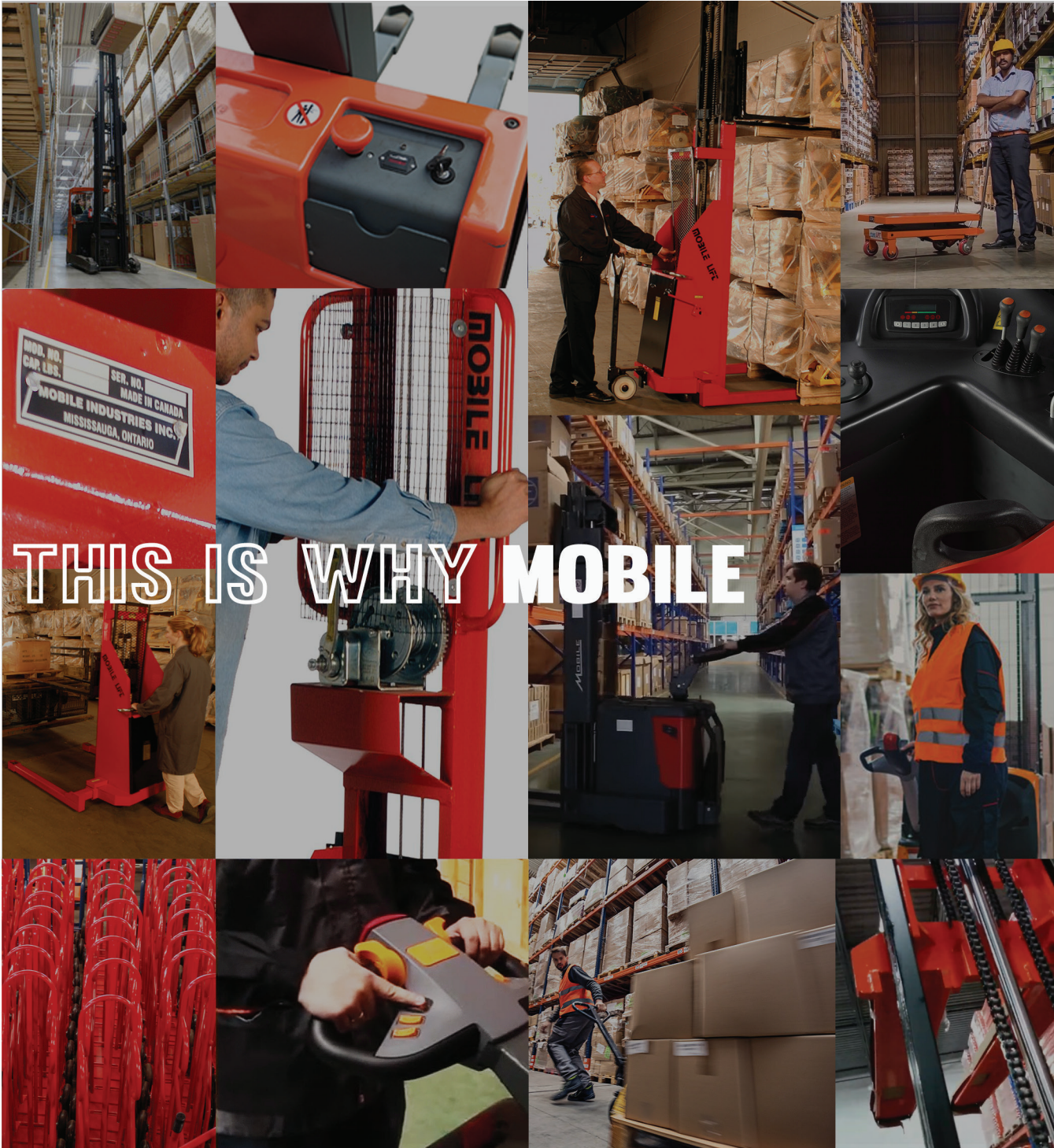

THIS IS WHY MOBILE

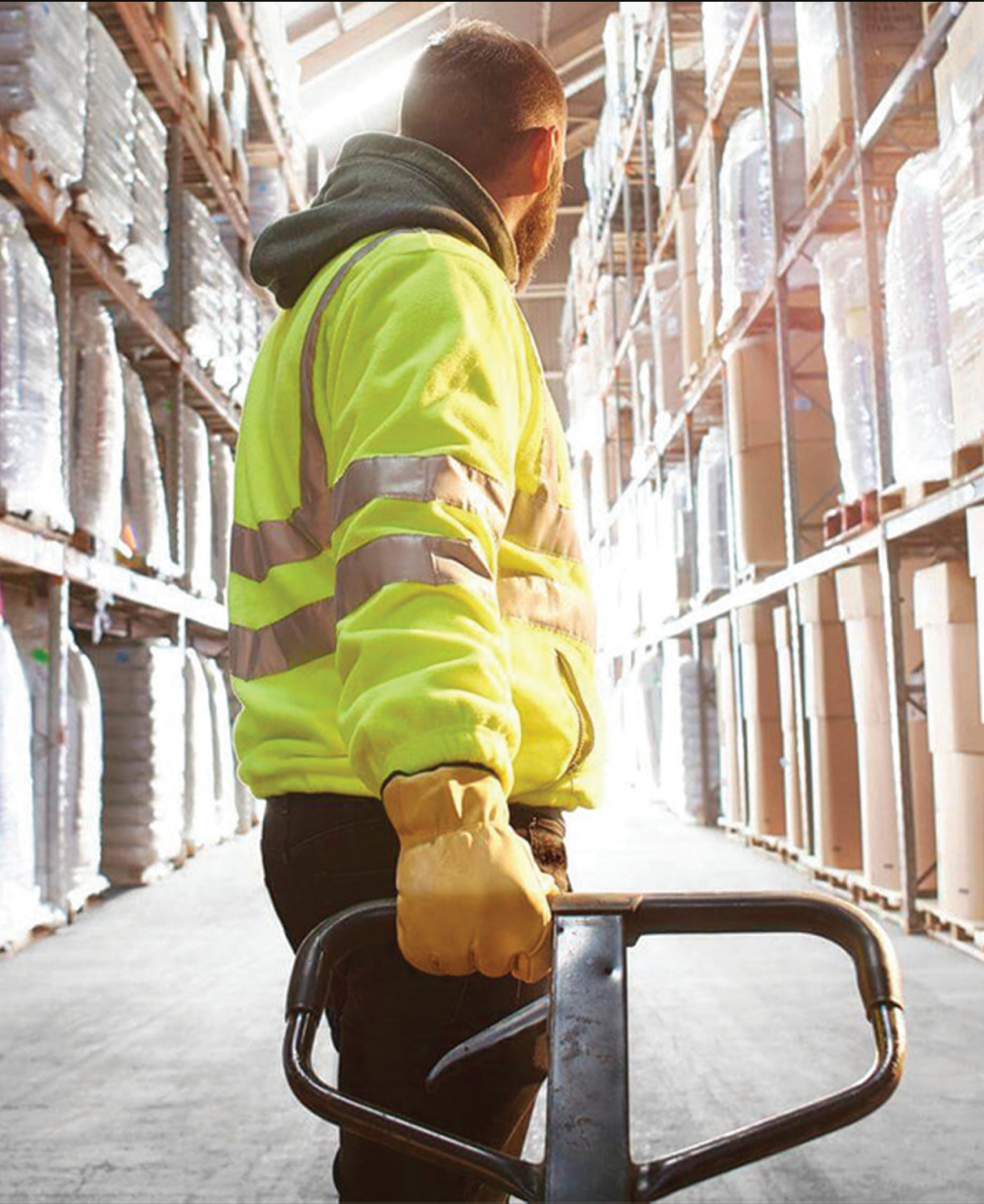

# MOVING THE WORLD ONE PALLET AT A TIME.

Count on Mobile to deliver dependable, easy-to-operate, economical and safe material handling equipment.

From tight formations to impossible to reach rafters, Mobile equipment can handle whatever needs moving in your world.



**MOBILE INDUSTRIES, INC.**  
3750 B Laird Rd - Unit 2&3  
Mississauga, ON L5L 0A6 • CANADA



**MOBILEPT.COM**



Toll Free: 1 800 527 4612 • Local: 905 279 5370