



# OPERATING INSTRUCTIONS

# ECO BATTERY STACKERS

**VERSION**

MARCH 2012

**MODEL**

EHS22N/ETHS22N ADJUSTABLE FORKS | EHS22FFN/ETHS22FFN FIXED FORK-OVER

**APPLICABLE PRODUCTS**

EHS22N, ETHS22N, EHS22FFN, ETHS22FFN

**WARNING:** Do not use the stacker before reading and understanding the operating instructions and warning labels on the stacker. Keep for future reference.

# CONTENTS

|   |    |
|---|----|
| Foreword .....                            | 2  |
| 1 Technical Parameter .....               | 3  |
| 2 Residual Lift Diagram .....             | 3  |
| 3 Safety Guidance.....                    | 5  |
| 4 Maintenance.....                        | 5  |
| 5 Battery Maintenance and Charging .....  | 6  |
| 6 Control Platform .....                  | 8  |
| 7 Troubleshooting .....                   | 9  |
| 8 Hydraulic System Schemaic Diagram ..... | 10 |
| 9 Circuit Diagram .....                   | 10 |

## Foreword

The safety instructions and important precautions are indicated with the following

icons:

1.  ---- This icon indicates the existence of a hazard that could result in personal injury if the safety instruction is not observed.

2.  ---- This icon indicates that a failure to observe the described instruction could lead to equipment damage.

3.  ---- This icon refers to general precautions and instructions before use.

 Most parts of the product are made from recyclable steel. The recycling and disposal of cast-offs produced during using, maintenance, cleaning and disassembling the product has to comply with local regulations without pollution to the environment. The recycling and disposal of the cast-offs should only be operated by specialized personnel in designated area. The wastes such as hydraulic oil, batteries and electronic units, if improperly disposed, may be hazardous to the environment and human health.

 Due to continuous product improvement, Mobile reserves the right to make changes in product designs and specifications without prior notice. For the latest product parameters, please feel free to contact us. Note: All parameters provided herein are as of the publication date of the Instruction Manual.

## 1) Technical Parameter

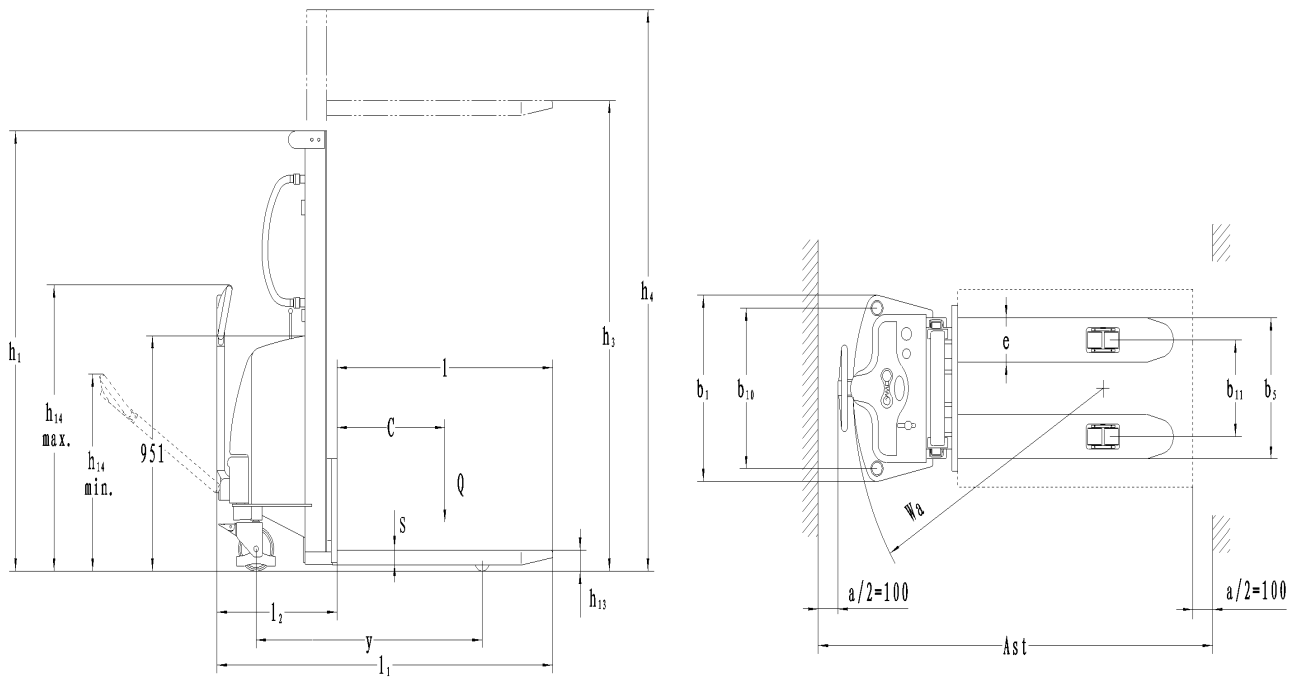

## 2) Residual Lift Diagram

| Lifting height (h3) mm        | Actual load capacity ( Q ) kg |               |  |
|-------------------------------|-------------------------------|---------------|--|
| 1500 / 59"                    | 1000 / 2200lbs                | 500 / 1100lbs |  |
| 2500 / 98.4"                  | 1000 / 2200lbs                | 400 / 880lbs  |  |
| 3000 / 118"                   | 600 / 1320lbs                 | 300 / 660lbs  |  |
| Load center distance ( C ) mm | 600                           | 800           |  |

## Technical Parameter

|                  |      |   |                           |                           |                           |
|------------------|------|---|---------------------------|---------------------------|---------------------------|
| Features         | 1.2  | Type  | EHS22FFN-63               | EHS22FFN-98               | EHS22FFN-118              |
|                  | 1.3  | Power: electric (battery)                     | Hand                      | Hand                      | Hand                      |
|                  | 1.4  | Driving mode                                  | Pedestrian                | Pedestrian                | Pedestrian                |
|                  | 1.5  | Rated load capacity: Q (kg)                   | 1000 / 2200lbs            | 1000 / 2200lbs            | 1000 / 2200lbs            |
|                  | 1.6  | Load center distance: c (mm)                  | 600 / 23.6"               | 600 / 23.6"               | 600 / 23.6"               |
|                  | 1.9  | Wheelbase: y (mm)                             | 1210 / 47.6"              | 1210 / 47.6"              | 1210 / 47.6"              |
| Weight           | 2.1  | Service weight (with battery): kg             | 350 / 770lbs              | 410 / 902lbs              | 430 / 946lbs              |
| Tires, chassis   | 3.1  | Tire type:                                    | Nylon/ PU                 | Nylon/ PU                 | Nylon/ PU                 |
|                  | 3.2  | Tire size, drive size: mm                     | 180x50 (7x2")             | 180x50 (7x2")             | 180x50 (7x2")             |
|                  | 3.3  | Tire size, load size: mm                      | 74x70 (2.9x2.7")          | 74x70 (2.9x2.7")          | 74x70 (2.9x2.7")          |
|                  | 3.5  | Wheel number (front/rear)                     | 2/4                       | 2/4                       | 2/4                       |
|                  | 3.6  | Wheel track (front): $b_{10}$ (mm)            | 680 / 26.7"               | 680 / 26.7"               | 680 / 26.7"               |
|                  | 3.7  | Wheel track (rear): $b_{11}$ (mm)             | 400/490 (15.7/19.2")      | 400/490 (15.7/19.2")      | 400/490 (15.7/19.2")      |
| Dimensions       | 4.2  | Enclosed mast height: $h_1$ (mm)              | 1980 / 77.9"              | 1830 / 72"                | 2080 / 81.9"              |
|                  | 4.4  | Lift height: $h_3$ (mm)                       | 1600 / 63"                | 2500 / 98"                | 3000 / 118"               |
|                  | 4.5  | Max. mast height: $h_4$ (mm)                  | 1980 / 77.9"              | 3070 / 120.8"             | 3570 / 140.5"             |
|                  | 4.9  | Height of tiller (min/max.): $h_{14}$ (mm)    | 790/1156 (31.1/45.5")     | 790/1156 (31.1/45.5")     | 790/1156 (31.1/45.5")     |
|                  | 4.15 | Height, lowered: $h_{13}$ (mm)                | 85 / 3.3"                 | 85 / 3.3"                 | 85 / 3.3"                 |
|                  | 4.19 | Overall length: $L_1$ (mm)                    | 1720/1570 (67.7/61.8")    | 1720/1580<br>(67.7/62.2") | 1720/1580<br>(67.7/62.2") |
|                  | 4.20 | Length to face of forks: $L_2$ (mm)           | 610/670 (24/26.3")        | 610/670 (24/26.3")        | 610/670 (24/26.3")        |
|                  | 4.21 | Overall width: $b_1$ (mm)                     | 777 / 30.5"               | 777 / 30.5"               | 777 / 30.5"               |
|                  | 4.22 | Fork dimensions: s/e/L (mm)                   | 60/180/1100<br>60/150/900 | 60/180/1100<br>60/150/900 | 60/180/1100<br>60/150/900 |
|                  | 4.25 | Distance between fork arms: $b_5$ (mm)        | 570<br>330~640            | 570<br>330~640            | 570<br>330~640            |
|                  | 4.33 | Aisle width (pallets 1000×1200): Ast (mm)     | 2230 / 87.7"              | 2230 / 87.7"              | 2230 / 87.7"              |
|                  | 4.34 | Aisle width (pallets 800×1200): Ast (mm)      | 2175 / 85.6"              | 2175 / 85.6"              | 2175 / 85.6"              |
|                  | 4.35 | Turning radius: $W_a$ (mm)                    | 1400 / 55.1"              | 1400 / 55.1"              | 1400 / 55.1"              |
| Performance data | 5.2  | Lift speed, laden/ unladen: mm/s              | 90/140                    | 90/140                    | 90/140                    |
|                  | 5.3  | Lowering speed, laden/ unladen: mm/s          | 120/100                   | 120/100                   | 120/100                   |
|                  | 5.11 | Service brake:                                | Manuel                    | Manuel                    | Manuel                    |
| Motor            | 6.2  | Lift motor rating at 15%: kw                  | 1.5                       | 1.5                       | 1.5                       |
|                  | 6.4  | Battery voltage/ nominal capacity: $K_5$ V/Ah | 12/150                    | 12/150                    | 12/150                    |
|                  | 6.5  | Battery weight: kg                            | 45 / 99lbs                | 45 / 99lbs                | 45 / 99lbs                |

### **3) Safety Guidance**

- 3.1 Do not use the stacker before reading and understanding the operating instructions and warning labels on the stacker.
- 3.2 Do not use the stacker without training and authorization.
- 3.3 Check and repair the stacker before use, pay special attention to the condition of wheels, handle, rollers, mast, and battery and so on.
- 3.4 Do not use on slope.
- 3.5 Never carry people on the fork.
- 3.6 Prohibit touching the mast when lifting loads.
- 3.7 Operators should wear safety gloves and antiskid shoes.
- 3.8 The fork height should not exceed 300mm (11.8”) when carrying loads.
- 3.9 All non-operating personnel should keep away from the stacker for over 600mm (23.6”) when lifting or carrying loads. Prohibit standing under the lifting forks.
- 3.10 The loads weight should be distributed onto the forks as evenly as possible. Prohibit stressing the force on one fork or the gravity of the loads is beyond two forks.
- 3.11 Do not use overloaded.
- 3.12 Check battery liquid when using or before charging, and replenish with distilled water if not enough.
- 3.13 The ambient environment should be dry, well-ventilated and away from fire when charging.
- 3.14 The forks should be lowered to the lowest position when not using.
- 3.15 The operator should be careful on special conditions/places when others cannot be protected.

### **4) Maintenance**

#### **4.1 Hydraulic Oil**

Check oil mass once every six mouths. Suggest using No.32 hydraulic oil (GB11118-89), its kinematic viscosity is 32cSt when it is on 400; the total amount is about 4.0 liter.

#### **4.2 Regular Maintenance**

In order to keep in good working order, necessary checks and maintenance everyday is suggested. Focusing mainly on: ( 1 ) wheels and mandrels, such as wires and rags bonded on the wheels and mandrels ; ( 2 ) whether the forks and the masts have deformation ; ( 3 ) whether the

voltage of the battery is normal and so on. After completing the work, unload the loads on the forks and lower the forks to the lowest position.

### **4.3 Lubrication**

Add grease or oil onto all moving parts frequently in order to lubricate.

## **5) Battery Maintenance and Charging**

### **5.1 Safety Operation Instructions for Battery**

Park the stacker securely and make it in a safe position before carrying out any operations for battery.

#### **5.1.1 Maintenance Personnel**

Only qualified personnel are allowed to handle the charging, maintenance and exchanging of the battery. The operation instructions, including operation manual, supply preparation and charging requirements must be carefully observed before operating.

#### **5.1.2 Fire Protection Measures**

Smoking and open fire is prohibited when handling battery. Keep away from inflammable materials when storing and charging the battery for at least 2m (78.7") distance. The area where to place the battery must be well-ventilated and equipped with fire-fighting equipments.

#### **5.1.3 The Maintenance of Battery**

1) Avoid over-charging and over-discharging of the battery and quick charging and under-charging is also forbidden. Otherwise they may affect the life of battery.

2) Charge the battery in time when it is discharged, time delay may damage the battery and better not over 24 hours. In very cold weather, the battery placed outdoors may not charge, it should be moved indoors to perform charging.

3) If the battery is not used for a long time, then it should be fully charged once a month.

4) The weight and dimension of the battery have a considerable influence on the stability of the stacker, thus allowed to modify the type of battery only after obtaining manufacturer's consent.

5) Avoid discharging in large current.

### **5.2 Disposal of Waste Battery**

The scrapped battery must be disposed according to local laws and regulations and stored in

environmental protection areas or waste disposal areas, this work should be operated by qualified specialized corporations.

### 5.3 Battery Indicator

**Battery indicator :** The status of battery discharging is indicated on the indicator with 10 bar graphs, each bar represents 10 percent of increment.

As the consumption of battery capacity, the lighting bars will fall down from the top.

Preset “Warning” sign will appear when the remaining capacity of battery meets the following conditions: when the remaining capacity of standard battery is 30 percent, the “Warning” sign will appear and you can charge the battery.

Preset “Warning” sign and a flashing “Stop” sign will appear when the remaining capacity of battery meets the following conditions: when the remaining capacity of standard battery is 20 percent, “Stop” sign will appear and keep lighting. When the “Stop” sign keeps lighting, the lifting function of the stacker will be cut off automatically.

Capacity sufficient

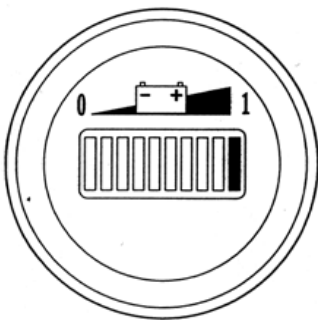

Recharging needed

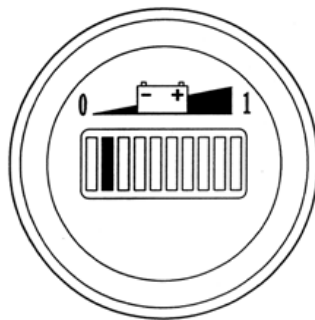

Low battery

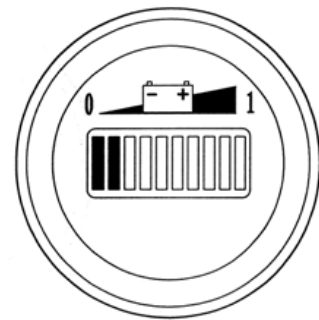

If the indicator shows low battery when lifting loads for a not very long period, the lifting function can only be re-performed after recharging the battery to at least 70 percent of the capacity.

### 5.3 Battery Charging

Keep well ventilation when charging the battery and ensure no metal objects are put on the battery. Check the connection places of all cables and plugs for obvious defects before performing charging operation. All safety commands, such as battery supply regulations and battery charging preparations should be strictly followed.



## 6) Control Platform

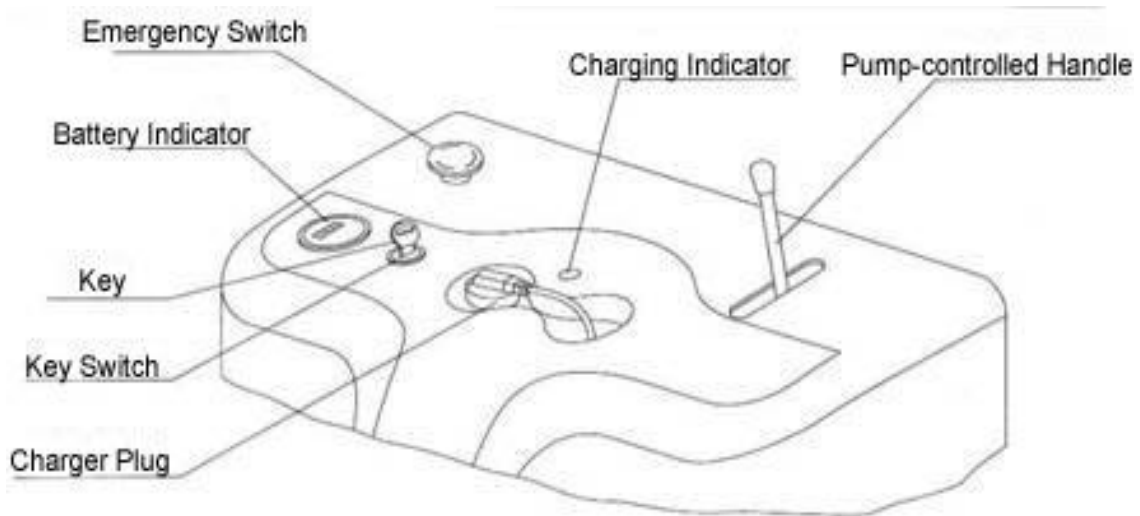

### 6.1 Emergency Switch

When you press the emergency switch, the pump station motor power will be cut off; and when you turn it clockwise again, the motor power will be connected.

### 6.2 Battery Indicator

This indicator shows the residual capacity of the battery. When the showing residual capacity is under 20 percent, you should recharging the battery ( see detailed introduction on last chapter 5.3).

### 6.3 Control Handle

This handle controls the lifting or the lowering of fork arms.

### 6.4 Charging Plug

This socket is a dedicated socket.

## 7) Troubleshooting

| No. | Fault                                     | Cause   | Countermeasures  |
|-----|---|---|--|
| 1   | Forks cannot be lifted to the max. height | - Hydraulic oil is not enough.  | - Add hydraulic oil.   |
| 2   | Forks cannot be lifted                    | - No hydraulic oil.<br>- Impurity of hydraulic oil.   | - Add hydraulic oil.<br>-Change hydraulic oil.   |
| 3   | Pump station motor cannot run             | - Emergency switch is not open.<br>- The voltage of battery is too low.<br>- The joint of cable line is loose.<br>- The motor contactor is damaged.   | - Turn the emergency switch clockwise.<br>- Charge<br>- Tighten<br>- Change for new one.   |
| 4   | Forks cannot be lowered                   | - Big piston rod or cylinder body has deformation because loads lean to one side or overload.<br>- Forks stay in a high position for a long time, leading to rust of the piston rod because of long-term bareness and block the movement of piston rod.<br>- The relief valve of hydraulic pump station cannot be opened because of wear or damage. | - Change big piston rod or cylinder body.<br>- Lower the fork to the lower position if not using, pay attention to lubricate the piston rod in time.<br>- Change the relief valve of pump station. |
| 5   | Oil leakage                               | - Sealing parts is aging or damaged.<br>- Some parts are cracked.   | - Change for new one.<br>- Change for new one.   |
| 6   | Forks are lowered by themselves           | - Impurity of hydraulic oil causes non-fastening of the relief valve.<br>- Sealing parts is aging or damaged.<br>- Relief valve is damaged.   | - Change hydraulic oil.<br>- Change for new one.<br>- Change for new one.  |
| 7   | Battery can not charging                  | - Battery is damaged.<br>- Charging plug is loose.  | - Change for new one.<br>-Tighten the plug.  |



**Prohibit to perform maintenance by yourself without authorization or training.**



## 9.2 Wiring Diagram

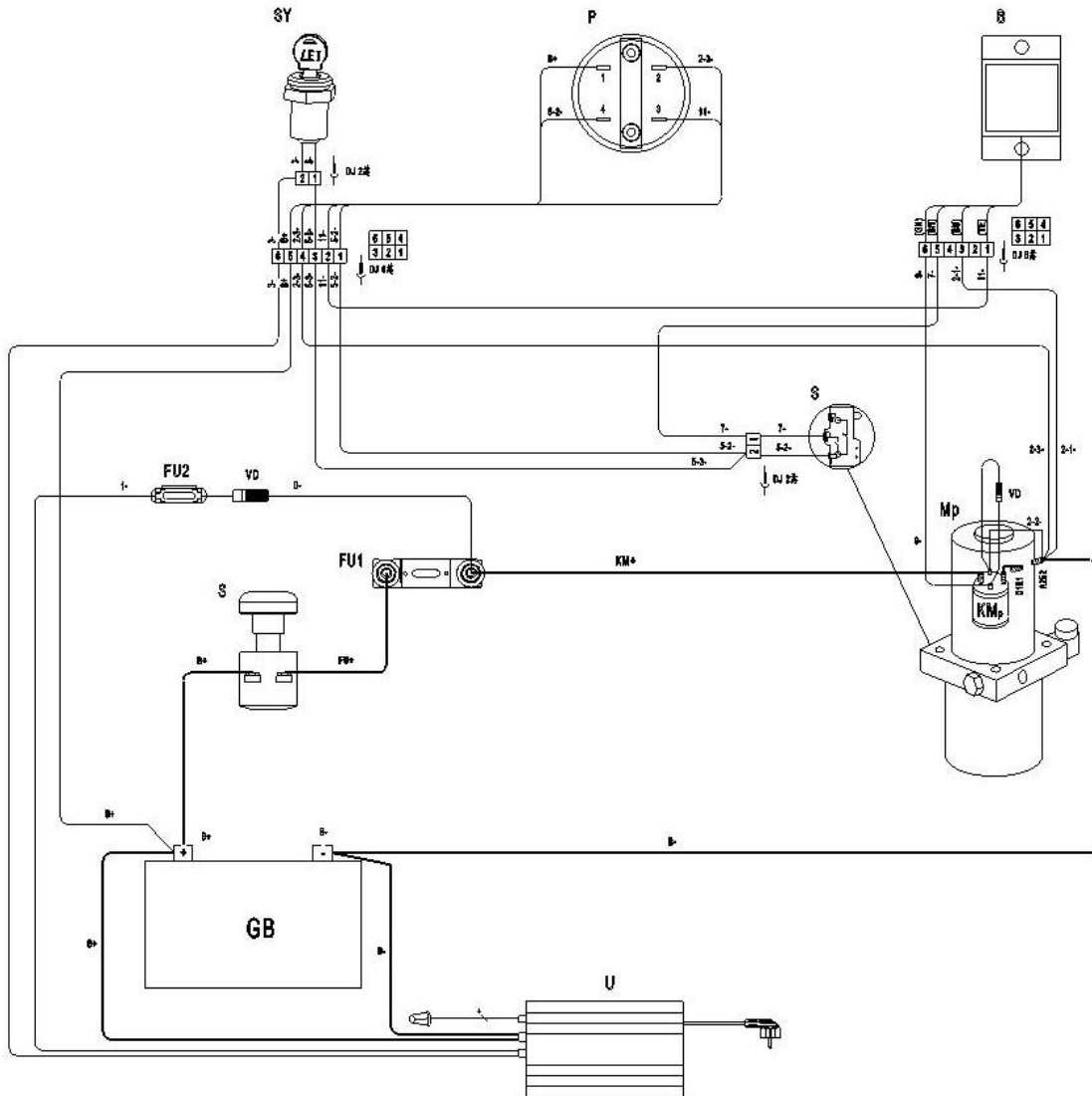



**MOBILE INDUSTRIES, INC.**  
3750B Laird Rd - Unit 2 & 3  
Mississauga ON, L5L 0R6  
Canada

Toll Free: 1 800 527 4612 • Local 905 279 5370  
Email: [info@mobilept.com](mailto:info@mobilept.com)

**MOBILEPT.COM**