

PARTS BREAKDOWN

LLS26FFNU LOW LIFT STACKER

VERSION

OCTOBER 2023

MODEL

LLS26FFNU LOW LIFT FORK-OVER STACKER

APPLICABLE PRODUCTS

LLS26-31FFNU, LLS26-63FFNU, LLS26-79FFNU, LLS26-79FFNU-L, LLS26FFNU, LLS26FFNU-L

Please order parts from authorized dealers of our company. In order to avoid wrong delivery, all the orders for spare parts should specify the following items:

- Truck model, identification number and manufacture year.
- Orders for spare parts of mast, hydraulic transmission unit, steering axle, motor, etc. shall indicate the manufacture number of these parts.
- Codes for our company spare parts are shown in the table of parts manual. Please also pay attention to the description of supply status, order quantity, etc. (check the number listed in "Mark" column of the parts manual).

"Mark" Column:

The unmarked indicates the parts are in short supply cycle.

Number 1: supply as package. Indicating these that parts are small parts and seal parts, which are supplied in package unit and in short supply cycle.

Number 2: supply with constraints. Indicating that these spare parts are not in stock and will be prepared for production after receiving the order from customers, which are in long supply cycle.

Number 3: phasing-out supply. Indicating that these parts will be replaced by new parts due to technical improvements and the current stock will not be available when these parts run out. Please check the description of technical improvements notice.

Number 4: supply as assembly. Indicating that these parts are assembly parts defined by manufacture process, which cannot be supplied as a single part.

Number 5: check other tables.

This parts manual is the property of our company and can be shared under the confidential agreement only, our company has the right to claim for compensation of any unauthorized use. Copy without permission is not allowed. Figures in the manual are not limited by the original design. Our company reserves the right to improve the products for continuous technology progress.

TABLE OF CONTENTS

Chapter: Drive system.....	4
01 Drive unit (537546013501).....	4
02 Drive assembly (537546013001).....	6
03 Motor assembly (537546013002).....	8
Chapter 2: Hydraulic system.....	10
01 Hydraulic unit (537546024001).....	10
02 Pump unit (537546023501).....	12
Chapter 3: Truck structure.....	14
01 Truck frame (537546021501).....	14
01 Truck frame (537546021501) Continue.....	16
01 Truck frame (532246021501) Continue.....	17
02 Forks (537546038001).....	18
03 Battery holder (537546012501).....	20
04 Battery holder (lithium battery) (537546012502).....	22
05 Control panel assembly (537546010001).....	24
Chapter 4: Steering system, braking system and wheels.....	26
01 Tiller (537546011001).....	26
02 Tiller head (537546011002).....	28
03 Load wheel (537546017001).....	30
04 Side wheel (537546016501).....	32
05 Manual steering (537546031201).....	34
Chapter 5: Electrical parts and wire harness.....	36
01 Wire harness (537546033001).....	36
02 Wire harness (lithium battery) (537546033002).....	38
03 Electrical control unit (537546033003).....	40
04 Charger (537546036501).....	42
Chapter 6: Special equipment.....	44
01 Load backrest (537546040502).....	44
Chapter 7: Others.....	46
01 Labels and decals (EU) (537546047001).....	46
02 Labels and decals (USA) (537546047002).....	48
Appendix.....	50
01 Electrical circuit diagram (lead-acid battery) (537546045501).....	50
02 Electrical circuit diagram (Lithium battery) (537546045502).....	51
03 Hydraulic circuit diagram (537546045503).....	52
04 Easy worn parts list.....	53

Chapter: Drive system

01 Drive unit (537546013501)

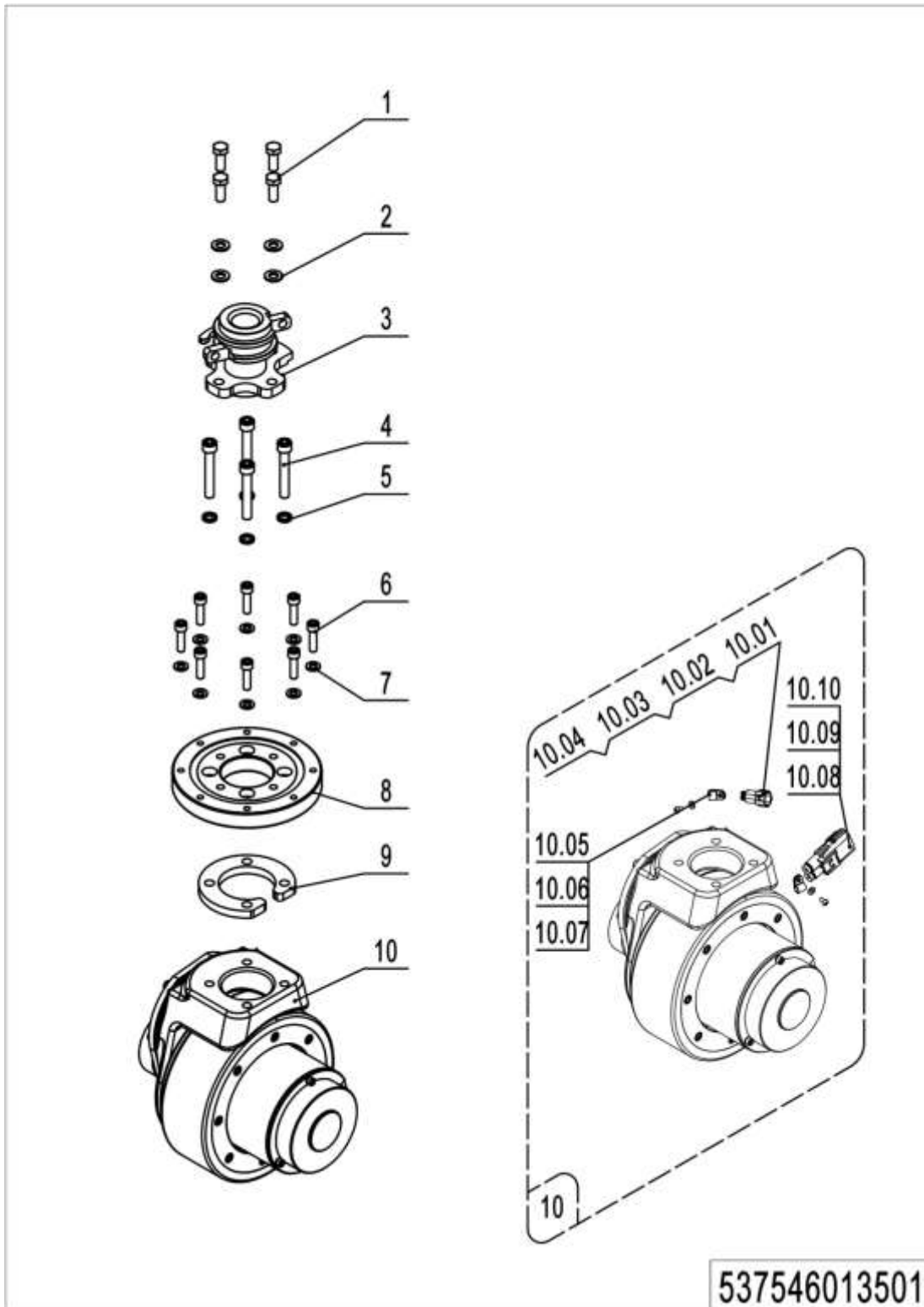

01 Drive unit (537546013501)

No.	Item Code	Mark	Item Description	Qty.	Substitute	Note
1	910100300036	1	Bolt	4		
2	910400100007	1	Flat Washer	4		
3	532231210005		驱动轴	1		
4	910200200079	1	Screw	4		
5	910400500007	1	Spring Washer	4		
6	910200200138	1	Screw	8		
7	910400100006	1	Flat Washer	8		
8	532213520001		Slewing Bearing	1		
9	532213520002		Plate	1		
10	508098510078	5	Drive Unit	1		PU wheel
	508098510079	5	Drive Unit	1		Anti-skip wheel
10.01	920400200004	1	Connector	1		
10.02	920400200003	1	Connector	1		
10.03	920400200017	1	Connector	2		
10.04	920400200018	1	Connector	2		
10.05	910200700001	1	Screw	2		
10.06	910400100003	1	Flat Washer	2		
10.07	921300200001		Cable Clamp	2		
10.08	920400200169	1	Connector	1		
10.09	920400200150	1	Connector	2		
10.10	920400200171	1	Connector	2		

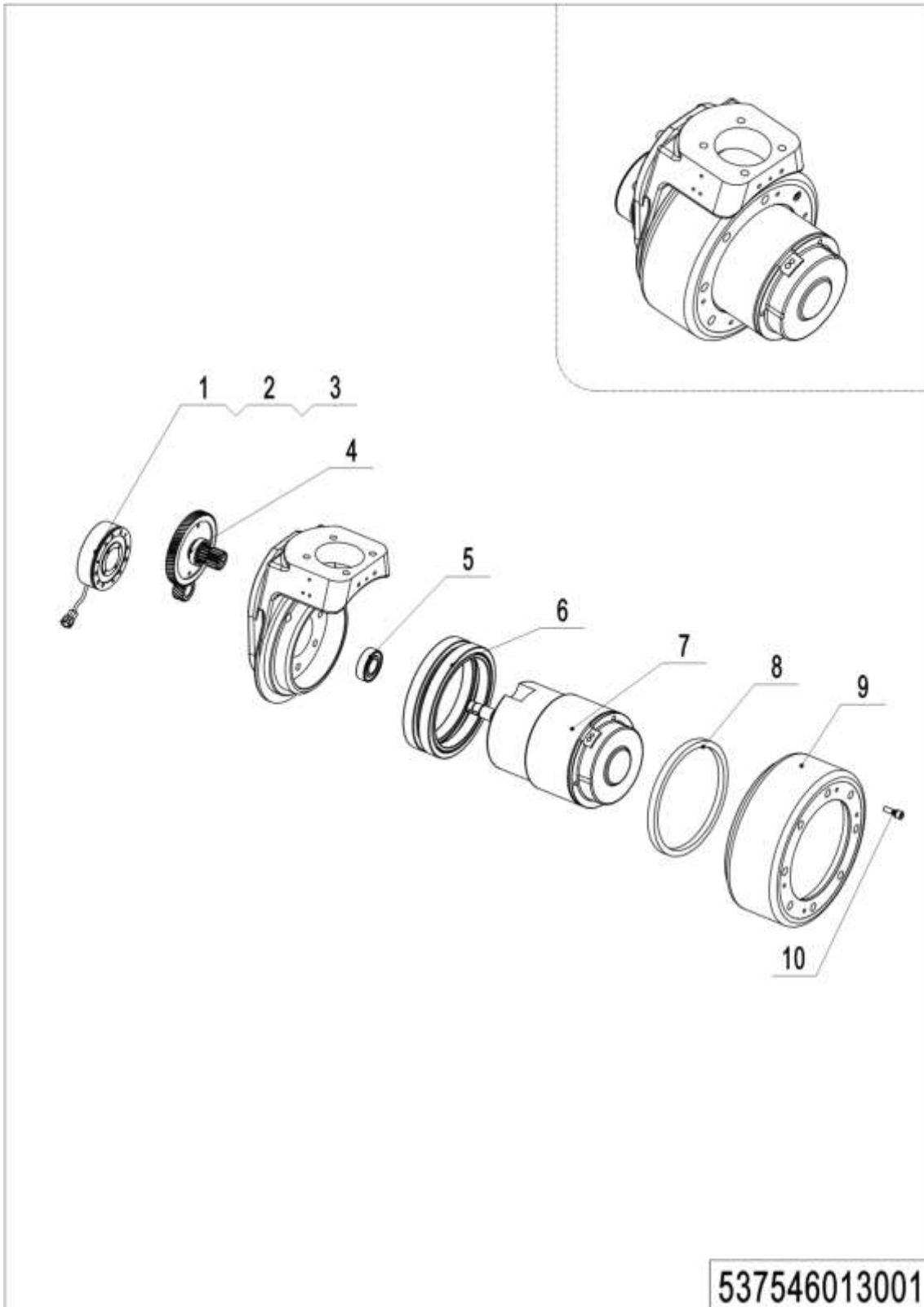
02 Drive assembly (537546013001)

02 Drive assembly (537546013001)

No.	Item Code	Mark	Item Description	Qty.	Substitute	Note
--	508098510078		Drive Unit	1		PU wheel
	508098510079		Drive Unit	1		Anti-skip wheel
1	508098520002	2	Brake	1		
2	508098520040	2	Rubber Strip	1		
3	910200200019	1	Screw	3		
4	508098510015	2	Gear Components	1		
5	910700200004	2	Bearing	1		
6	508098520011	2	Gear Ring	1		
7	508098510016	5	Motor	1		Check 537546013002
8	508098520032	2	Seal	1		
9	508098520003		Wheel	1		
	508098520026		Wheel	1		
10	910200200167	1	Screw Kits	8		

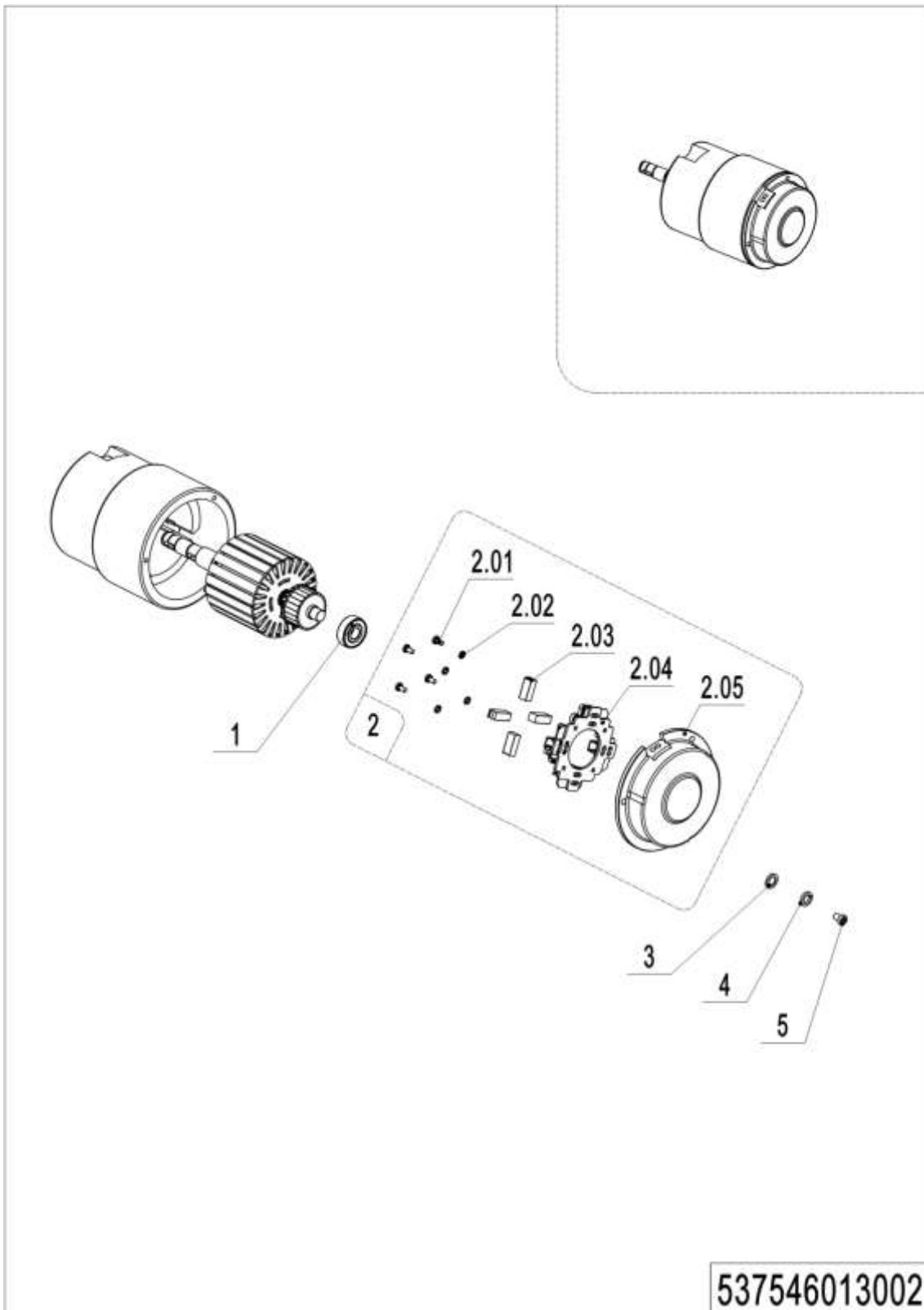
03 Motor assembly (537546013002)

03 Motor assembly (537546013002)

No.	Item Code	Mark	Item Description	Qty.	Substitute	Note
--	508098510016	2	Motor	1		
1	910700200016	2	Bearing	1		
2	508098510074	2	End Cap	1		
2.01	910200500034	1	Screw	4		
2.02	910400500003	1	Spring Washer	4		
2.03	508098520000	2	Carbon Brush	4		
2.04	508098520001	2	Carbon Brush Holder	1		
2.05	508098520036	2	End Cap	1		
3	910400100002	1	Flat Washer	3		
4	910400500002	1	Spring Washer	3		
5	910200200023	1	Screw	3		

Chapter 2: Hydraulic system

01 Hydraulic unit (537546024001)

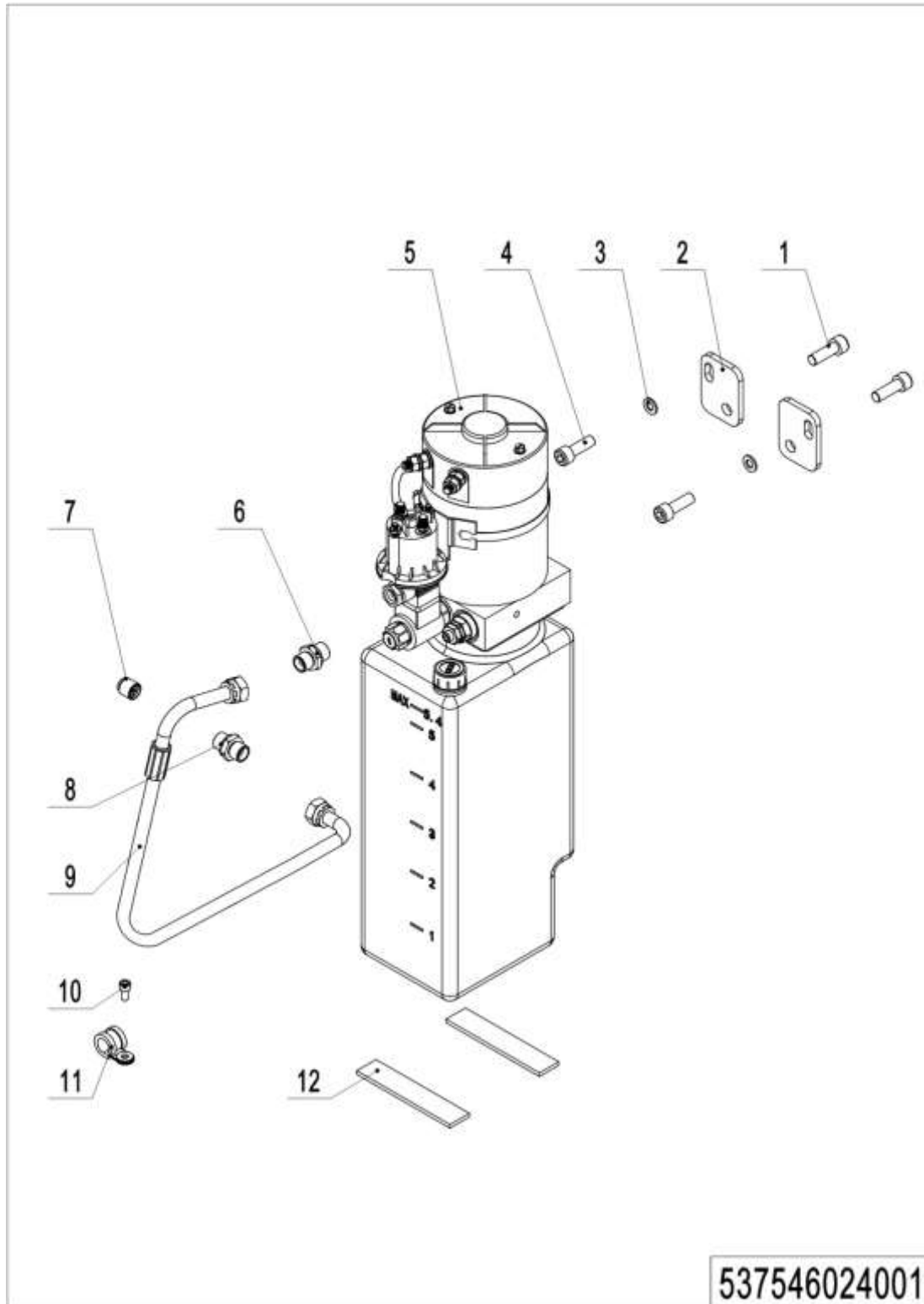

01 Hydraulic unit (537546024001)

No.	Item Code	Mark	Item Description	Qty.	Substitute	Note
1	910200200074	1	Screw	2		
2	532223520001		Plate	2		
3	910400100006	1	Flat Washer	2		
4	910200200053	1	Screw	2		
5	950900100069	5	Pump Unit	1		See 537546023501
6	950400300007		Joint	1		
7	950600300001		Safety Valve	1		
8	950400400003		Joint	1		
9	537524020001		--	1		
10	910200200033	1	Screw	1		
11	951000100003		Hose Clamp	1		
12	532223520010		--	2		

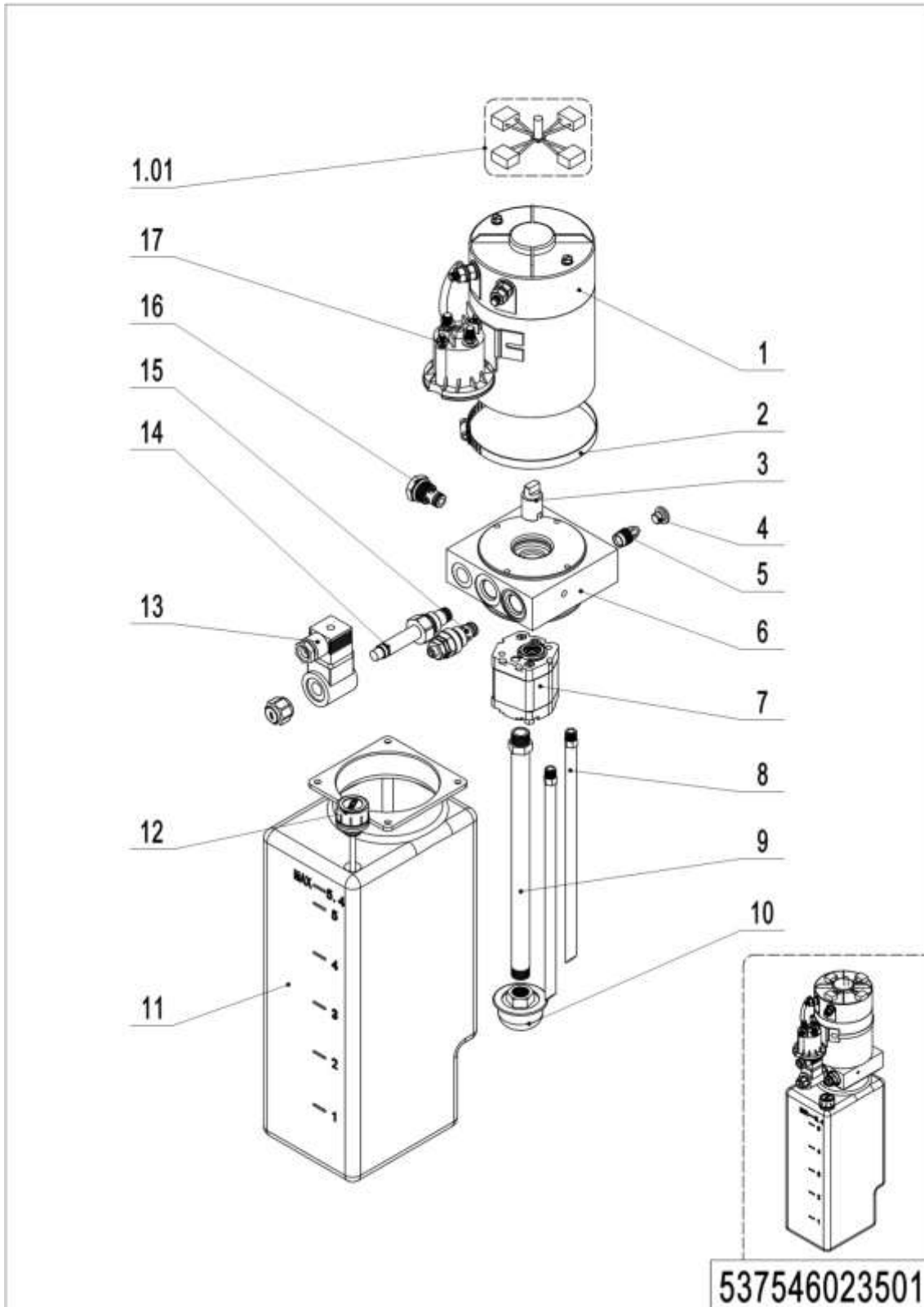
02 Pump unit (537546023501)

02 Pump unit (537546023501)

No.	Item Code	Mark	Item Description	Qty.	Substitute	Note
--	950900100096		--	1		
1	532298510056		--	1		
1.01	532298510058		--	1		
2	532298510040		Hose Clamp	1		
3	532298520007		Coupling	1		
4	532298520003		End Cap	1		
5	532298510027		Valve	1		
6	532298520006		Valve Block	1		
7	532298510057		Gear pump	1		
8	532298520004		Pipe	2		
9	532298520005		Oil Tube	1		
10	532298510031		Filter	1		
11	532298510029		Tank	1		
12	532298510030		Cap-Tank	1		
13	532298510034		Coil	1		
14	532298510033		Magnetic Valve	1		
15	532298510044		Overflow valve	1		
16	532298510028		Check Valve	1		
17	532298510036		Switch	1		

Chapter 3: Truck structure

01 Truck frame (537546021501)

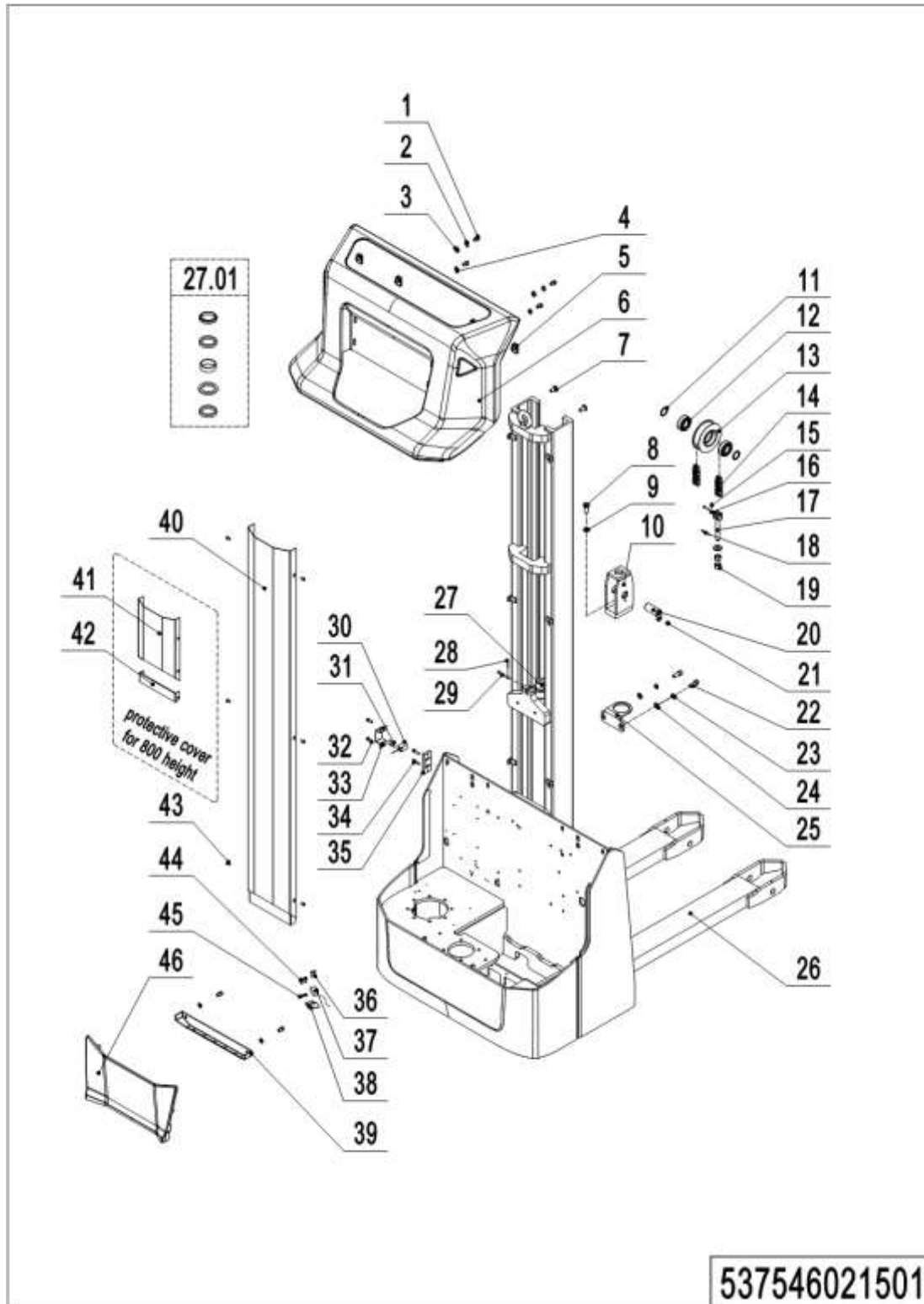

01 Truck frame (532246021501)

No.	Item Code	Mark	Item Description	Qty.	Substitute	Note
1	910200200053	1	Screw	6		
2	910400600004	1	Spherical Washer	2		
3	910400700004	1	Cone Washer	2		
4	910400100006	1	Flat Washer	4		
5	940400400003		Cage Nut	4		
6	532221510003		Cover	1		
7	941100100005		Screw	2		
8	910100300049		Bolt	1		
9	910400500008		Spring Washer	1		
10	537521510002		Yoke	1		
11	940600500006		Washer	2		
12	910700200020		Bearing	2		
13	940200400002		Sprocket	1		
14	532344510004		Chain	1		2000
	532344510009		Chain	1		1600
	560824510008		Chain	1		800
15	910600600006		Cotter Pin	1		
16	941100800010		Pin	1		
17	206044520060		Chain Anchor	1		
18	910600600019		Cotter Pin	1		
19	910300200008		Nut	2		
20	533243510005		Pin	1		
21	910200400016		Screw	1		
22	910200200076		Screw	2		
23	910400500007		Spring Washer	2		
24	910400100007		Flat Washer	2		
25	537521520011		Mounting Plate	2		
26	537521510001		Chassis	1		570x1150,2000
	537521510006		Chassis	1		570x1150,1600
	537521510007		Chassis	1		570x1150,800

01 Truck frame (537546021501) Continue

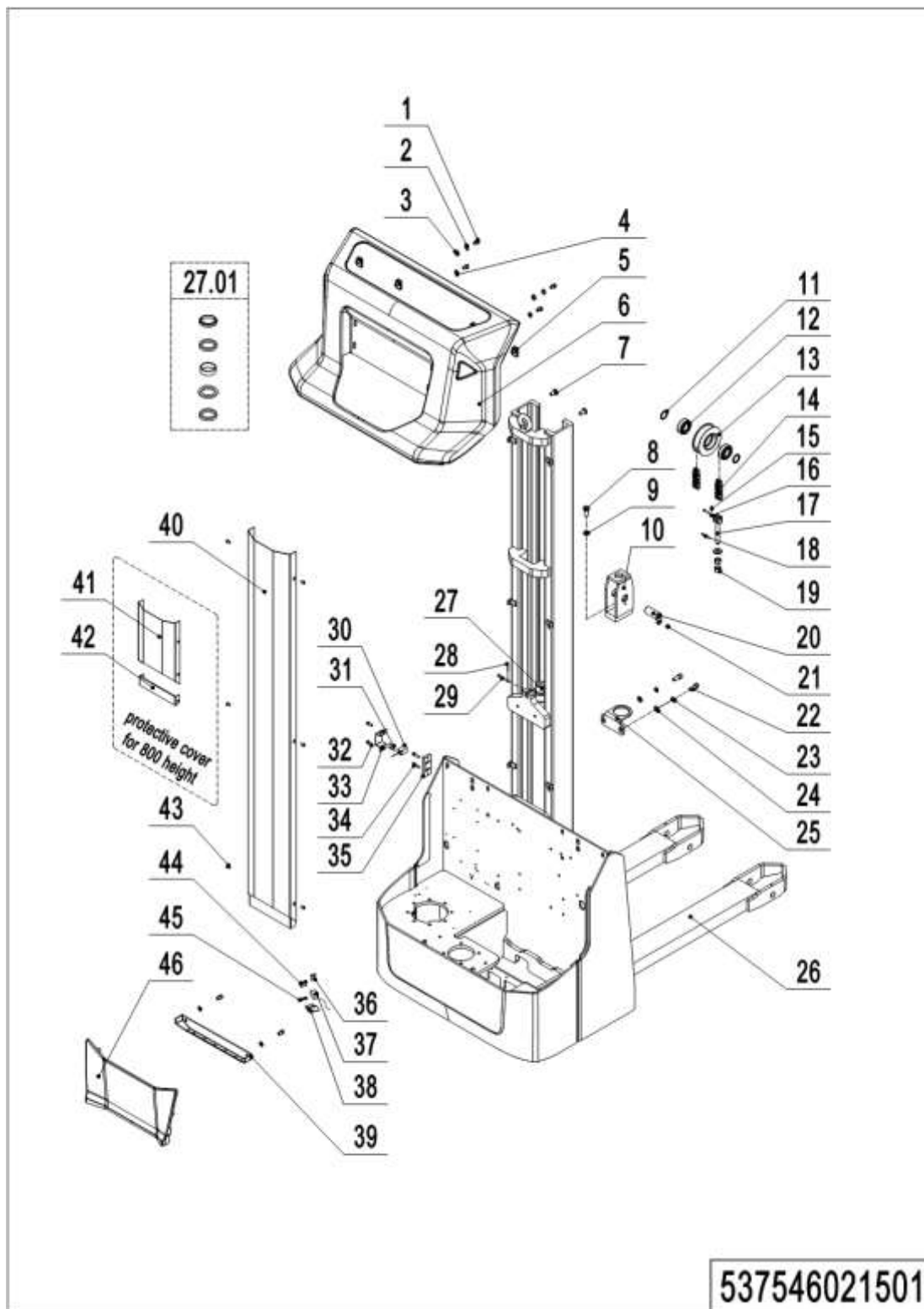

01 Truck frame (532246021501) Continue

No.	Item Code	Mark	Item Description	Qty.	Substitute	Note
	537521510008		Chassis	1		685x1150,2000
	537521510009		Chassis	1		685x1150,1600
	537521510010		Chassis	1		685x1150,800
27	537543010000		Cylinder	1		800
	532243010001		Cylinder	1		1600
	532243010004		Cylinder	1		2000
27.01	532298510002		Seal Kit	1		
28	910600600015		Cotter Pin	1		
29	941100800006		Pin	1		
30	920200400030		Proximity Switch	1		
31	910200200005		Screw	2		
32	910200200033		Screw	2		
33	532421520001		Protective Cover	1		
34	910200200035		Screw	2		
35	532421520003		Mounting Plate	1		
36	910200500015	1	Screw	2		
37	920200400017		Proximity Switch	1		
38	532221520031		Mounting Plate	1		
39	532221520025		Cover	1		
40	537521510003		Protective Cover	1		2000
	537521510004		Protective Cover	1		1600
41	537521520019		Protective Cover	1		800
42	537521520022		Protective Cover	1		800
43	910200300016		Screw	6		
44	910200200033	1	Screw	7		
45	910400100005	1	Flat Washer	7		
46	532221520024		Panel	1		

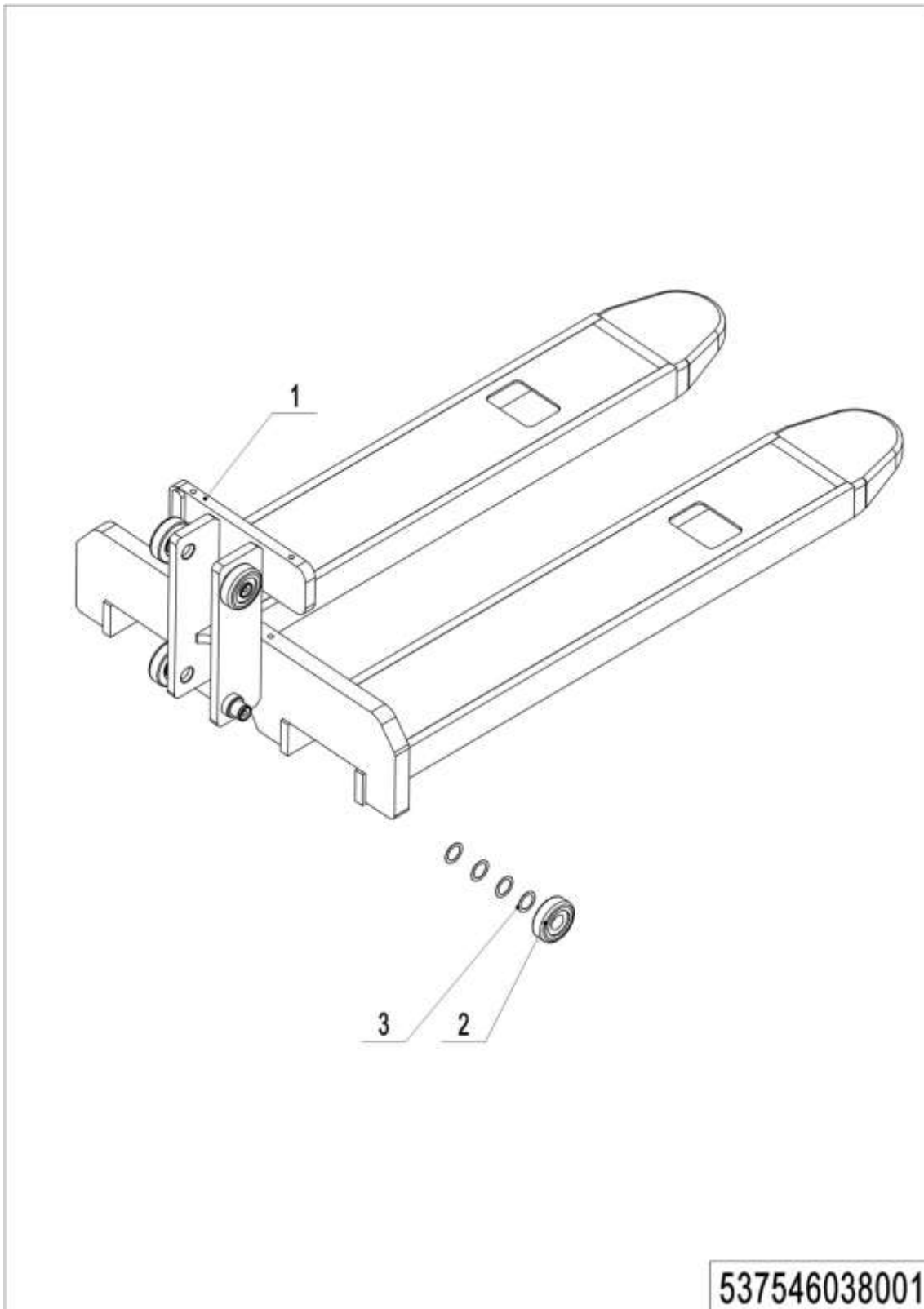
02 Forks (537546038001)

02 Forks (537546038001)

No.	Item Code	Mark	Item Description	Qty.	Substitute	Note
1	537538010001	2	Fork	1		570x1150
	537538010002	2	Fork	1		685x1150
2	940200100038		Main Roller	4		
3	940600500016		Washer	24		on demand

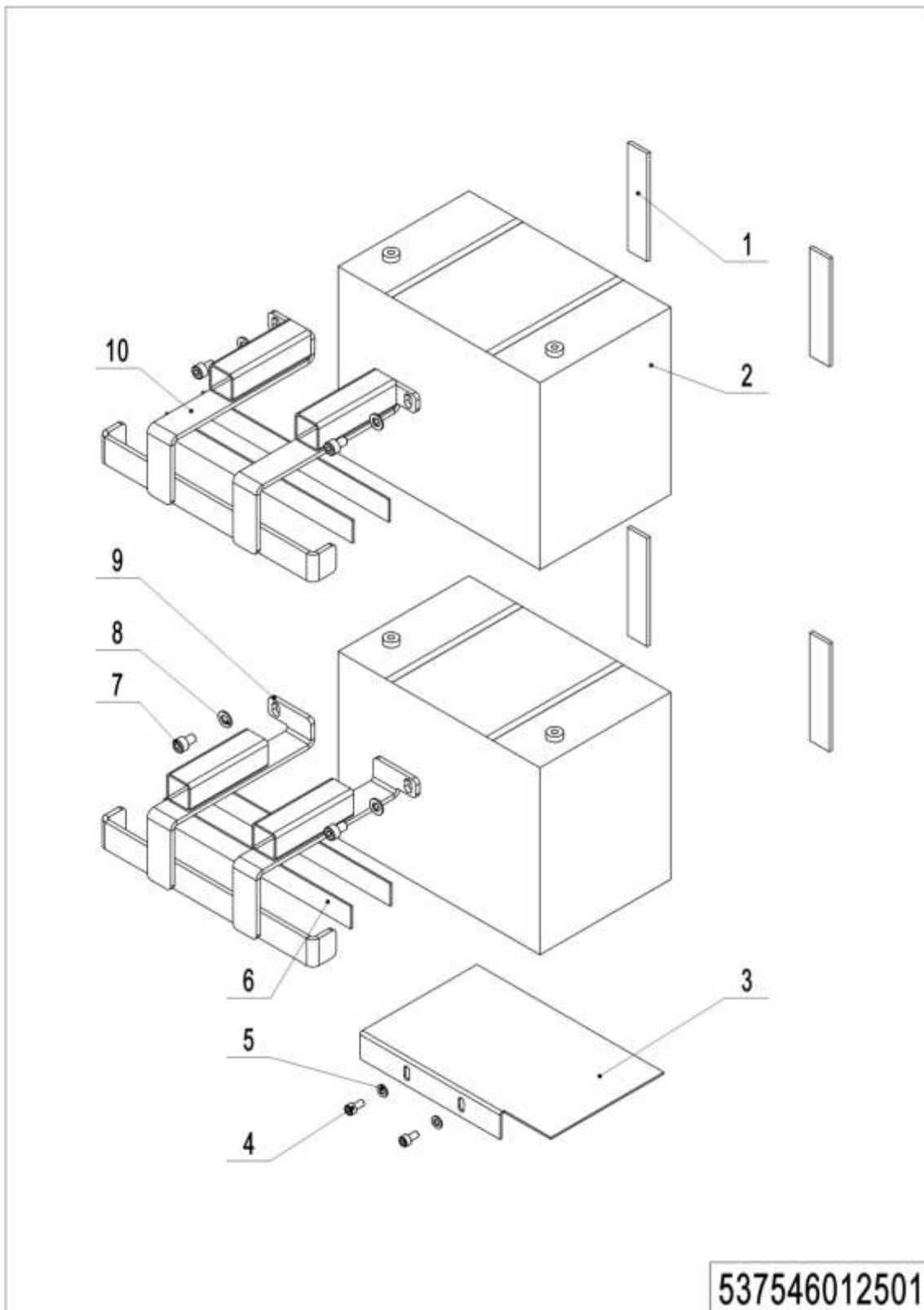
03 Battery holder (537546012501)

03 Battery holder (537546012501)

No.	Item Code	Mark	Item Description	Qty.	Substitute	Note
1	532223520010		Crash Pad	4		
2	920600100105		Battery12V85Ah	2		TN
	920600100107		Battery12V106Ah	2		TN
3	532212520006		Mounting Plate	1		
4	910200200033	1	Screw	2		
5	910400100005	1	Flat Washer	2		
6	532233020005		Crash Pad	4		85Ah
7	910200200053	1	Screw	4		
8	910400100006	1	Flat Washer	4		
9	532212510002		Mounting Plate	1		85Ah
	532212510004		Mounting Plate	1		106Ah
10	532212510001		Mounting Plate	1		85Ah
	532212510003		Mounting Plate	1		106Ah

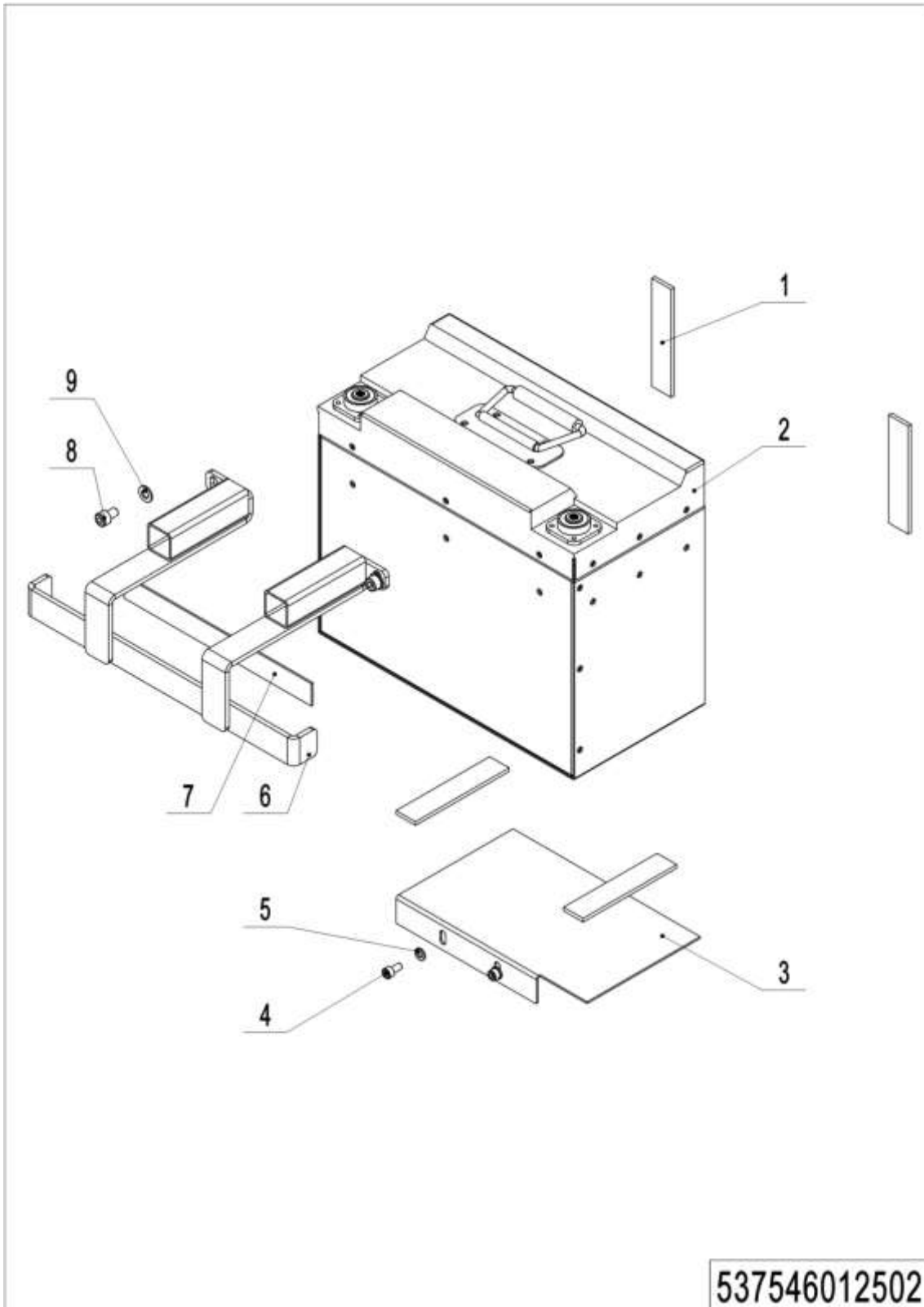
04 Battery holder (lithium battery) (537546012502)

04 Battery holder (lithium battery) (537546012502)

No.	Item Code	Mark	Item Description	Qty.	Substitute	Note
1	532223520010		Crash Pad	4		
2	920600100082		Li Battery24V60Ah	1		
3	532212520006		Mounting Plate	1		
4	910200200033	1	Screw	2		
5	910400100005	1	Flat Washer	2		
6	532212510003		Mounting Plate	1		
7	532233020005		Crash Pad	1		
8	910200200053	1	Screw	2		
9	910400100006	1	Flat Washer	2		

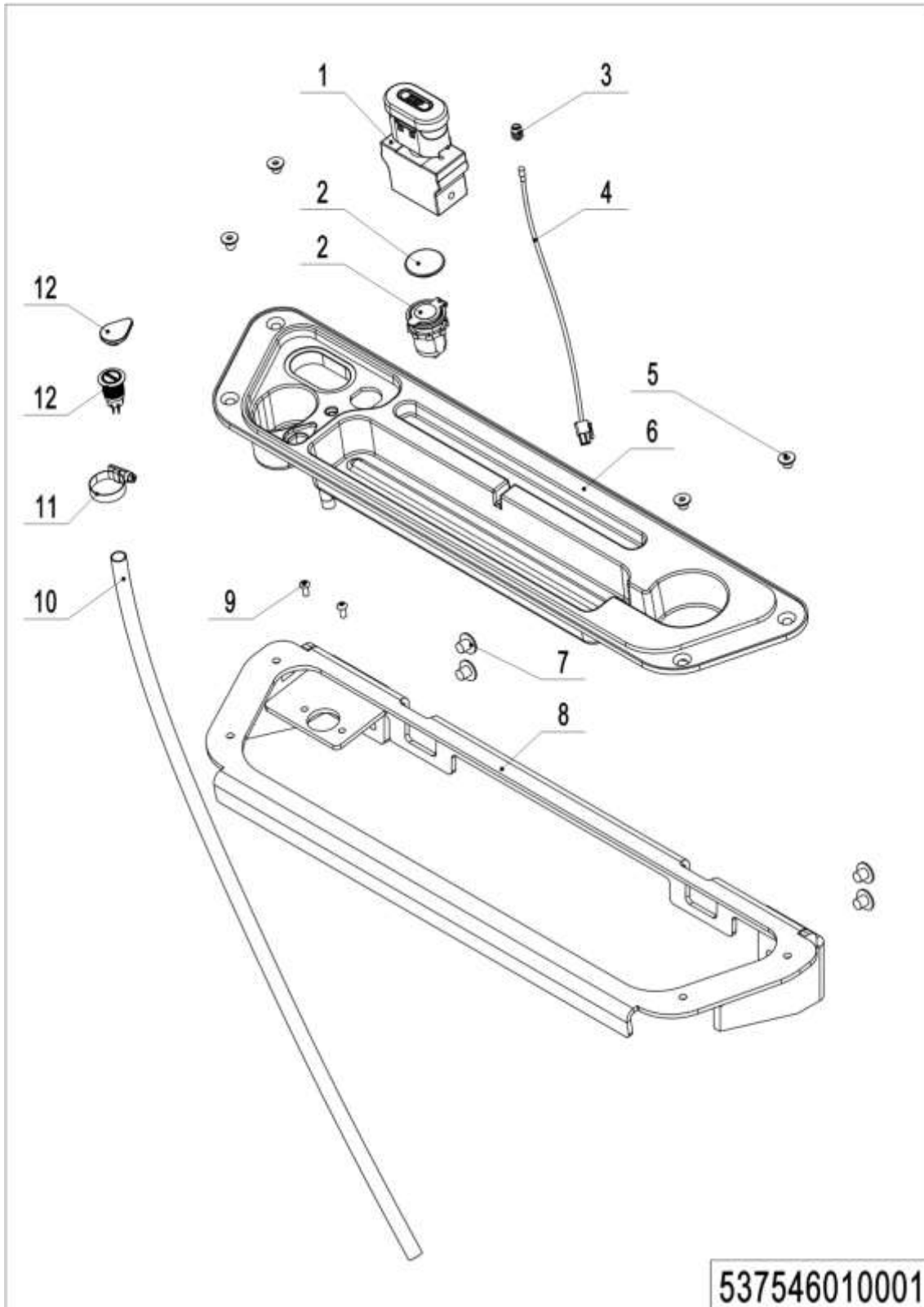
05 Control panel assembly (537546010001)

05 Control panel assembly (537546010001)

No.	Item Code	Mark	Item Description	Qty.	Substitute	Note
1	920200100009		Emergency Button	1		
2	532210020003		Close Plate	1		Lead-acid battery
	206033010036		USB interface	1		Lithium battery
3	922000100024		Lamp Holder	1		
4	532298510006		Indicator Light	1		
5	910200400023	1	Screw	4		
6	532210020001		Bezel	1		
7	941100100005		Screw	4		
8	532210010001		Mounting Plate	1		
9	910200300012	1	Screw	2		
10	532210020008		Pipe	1		
11	911000600008		Hose Clamp	1		
12	532210020002		Close Plate	1		Lead-acid battery
	532233010023		Button	1		Lithium battery

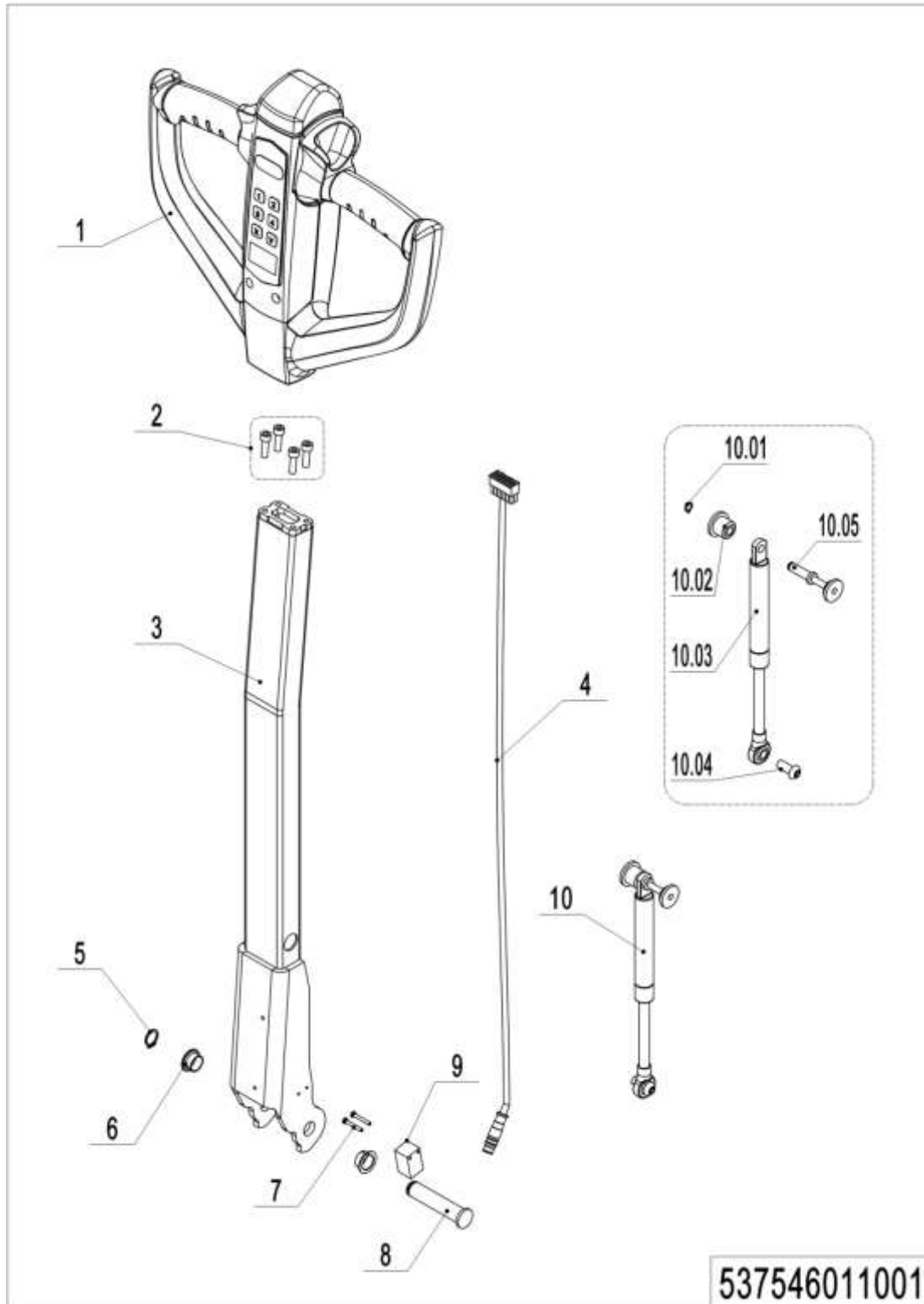
Chapter 4: Steering system, braking system and wheels**01 Tiller (537546011001)**

01 Tiller (537546011001)

No.	Item Code	Mark	Item Description	Qty.	Substitute	Note
1	922100100021		Tiller	1		
	922100100028		Tiller	1		IC card
2	910200200036	1	Screw	4		
3	532211010000		Tiller	1		
4	532233010019		Wire Harness	1		
5	910401300006		Circlip	1		
6	940500200001		Bushing	2		
7	941101100001	1	Screw	2		
8	508011020004		Pin	1		
9	505633510001		Proximity Switch	1		
10	532298510039		Air spring kits	1		
10.1	910401300001		Circlip	1		
10.2	508011020005		Fixing Base	1		
10.3	532211020003		Gas Spring	1		
10.4	941100100011	1	Screw	1		
10.5	508011010002		Pin	1		

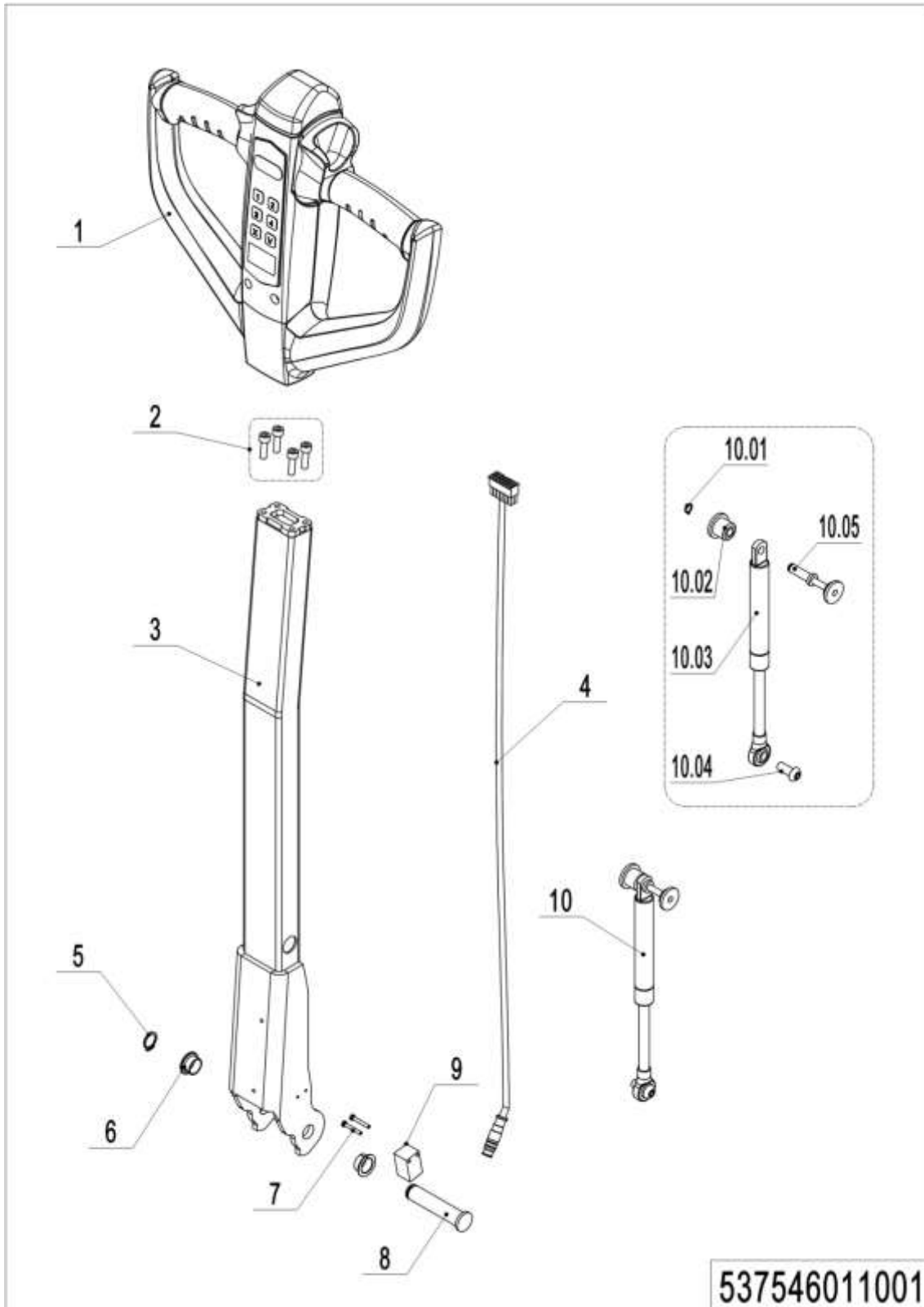
02 Tiller head (537546011002)

02 Tiller head (537546011002)

No.	Item Code	Mark	Item Description	Qty.	Substitute	Note
1	532298510022		Handle Cap Kit	1		
	532298510023		Handle Cap Kit	1		IC card
1.01	910200200003	1	Screw	2		
1.02	910400500002	1	Spring Washer	2		
1.03	508098520014		Traction lever	1		
1.04	910200200159	1	Screw	2		
1.05	508098520027		ID Card	1		With RFID card function
1.06	532298510054		--	1		
	532298510055		--			IC card
1.07	508098520020		Traction lever	1		
1.08	508098520015		Bushing	2		
1.09	508098520016		Bushing	2		
1.10	532298510005		Accelerator	1		
	532298510007		Accelerator	1		IC card
2	508098510031		Handle Cap Kit	1		
2.01	508098520018		Cap,Break Switch	1		
2.02	508098520019		Bracket	1		
2.03	502311020018		Spring	4		
2.04	508098520012		Handle Cap	1		
2.05	508098510029		Microswitch Kits	1		
2.06	508098510030		Microswitch Kits	1		
2.07	508098520013		Handle	2		
2.08	910200200058	1	Screw	2		
2.09	910400500006	1	Spring Washer	2		
2.10	502311020022		Spring	6		
2.11	508098520031		Button	1		
2.12	508098520030		Button	1		
2.13	508098520029		Horn Button	1		

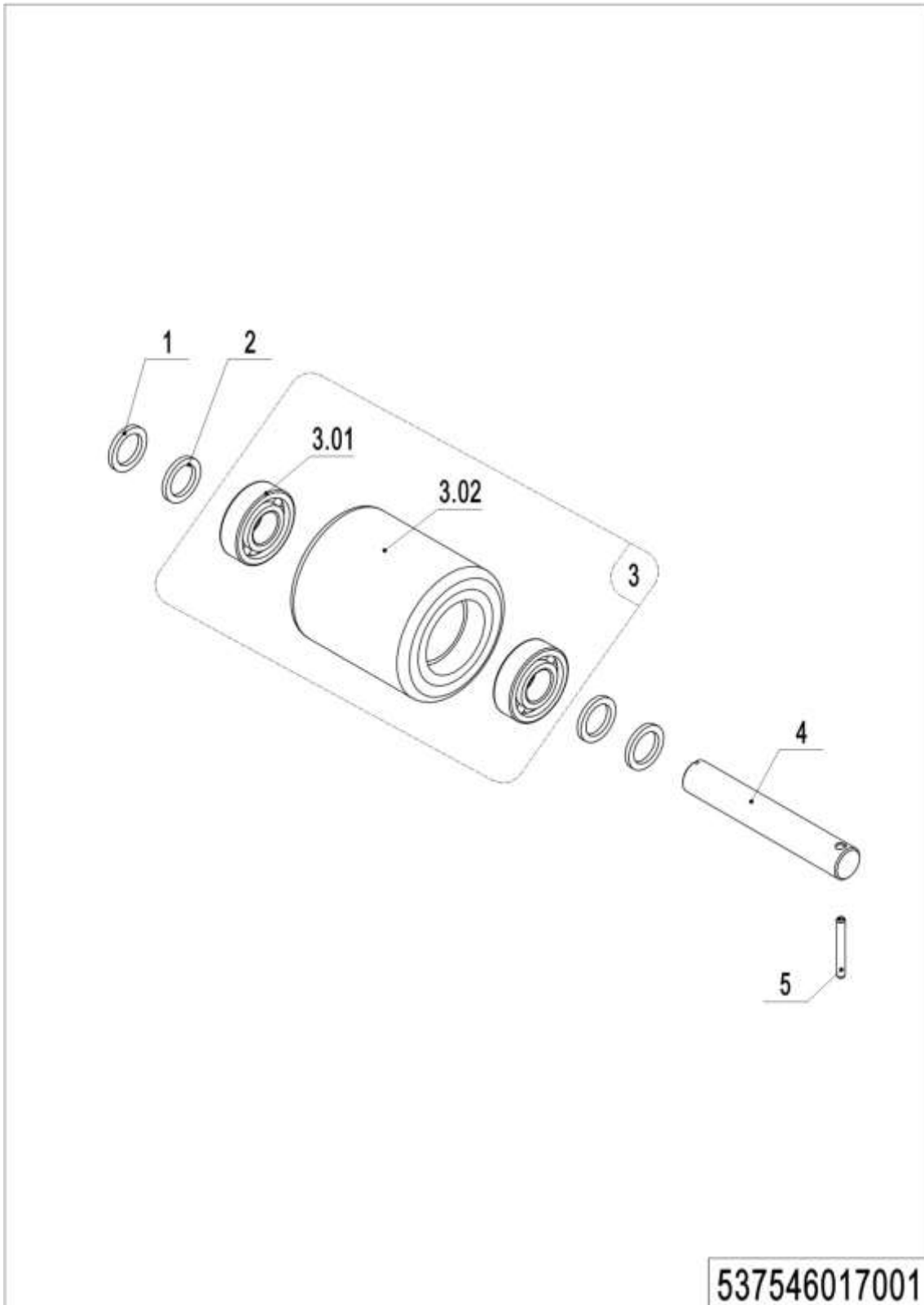
03 Load wheel (537546017001)

03 Load wheel (537546017001)

No.	Item Code	Mark	Item Description	Qty.	Substitute	Note
1	940600500013		Washer	4		
2	940600500053		Washer	4		
3	532298510003		Wheel	2		
3.01	910700200019		Bearing	4		
3.02	940300300011		Wheel Φ 84x93	2		
4	532217020001		Axle	2		
5	910600400028		Spring Pin	2		

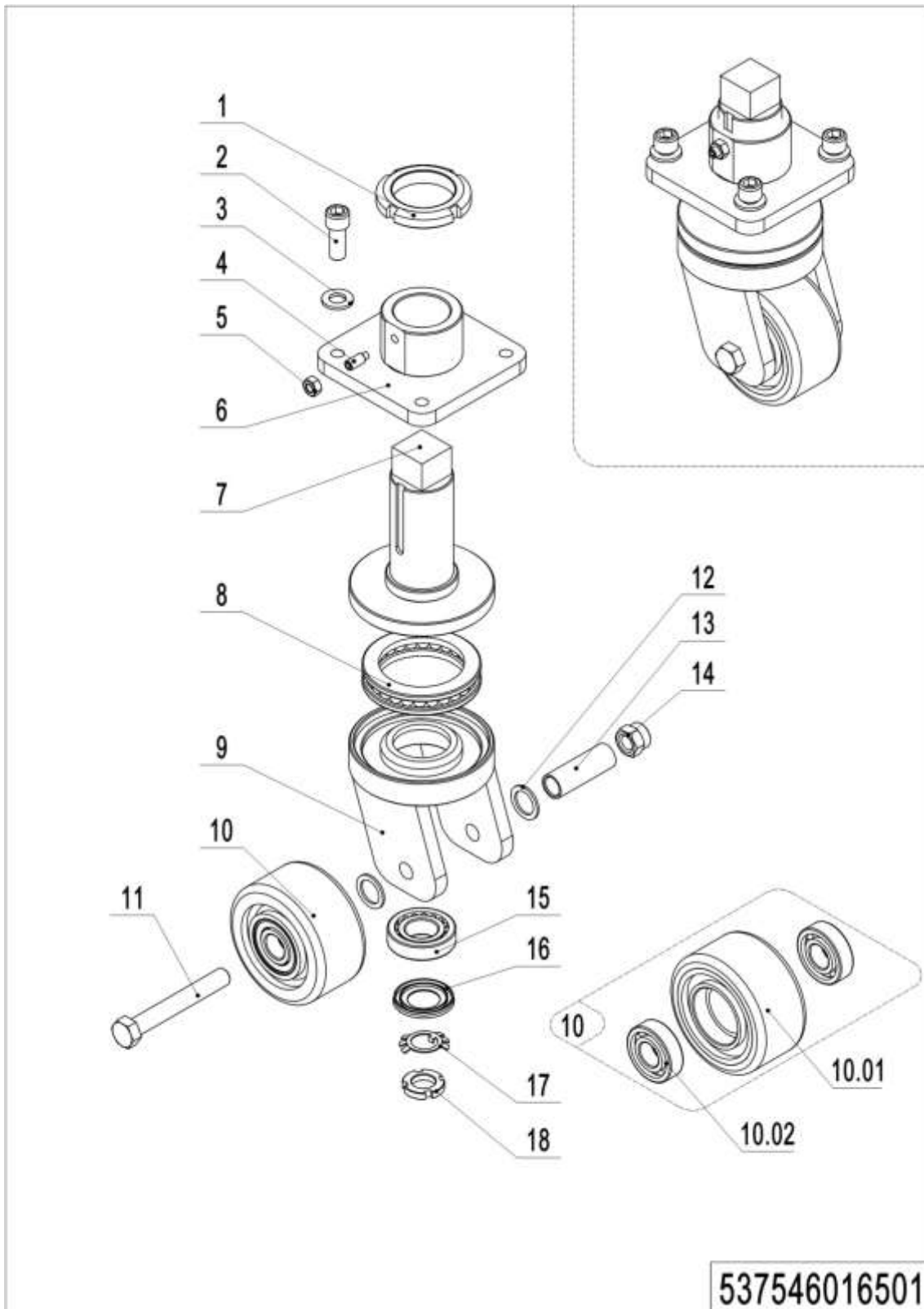
04 Side wheel (537546016501)

04 Side wheel (537546016501)

No.	Item Code	Mark	Item Description	Qty.	Substitute	Note
--	532298510041		Caster Assembly	1		
1	941100900004	1	Nut	1		
2	910200200098	1	Screw	4		
3	910400100008	1	Flat Washer	4		
4	910201000012	1	Screw	1		
5	910300100006	1	Nut	1		
6	532216510003	2	Fixing Base	1		
7	532216510002	2	Axle	1		
8	910700700011		Bearing	1		
9	532216510001	2	Wheel Carrier	1		
10	532298510004		Caster Assembly	1		
10.01	940300300030		WheelΦ100x50	1		
10.02	910700200019		Bearing	2		
11	910100100069	1	Bolt	1		
12	940600500005	1	Washer	4		
13	532216520006		Sleeve	1		
14	910300500007	1	Nut	1		
15	910700600001		Bearing	1		
16	941101000010		Cover	1		
17	910400900002	1	Lock Washer	1		
18	910300700008	1	Nut	1		

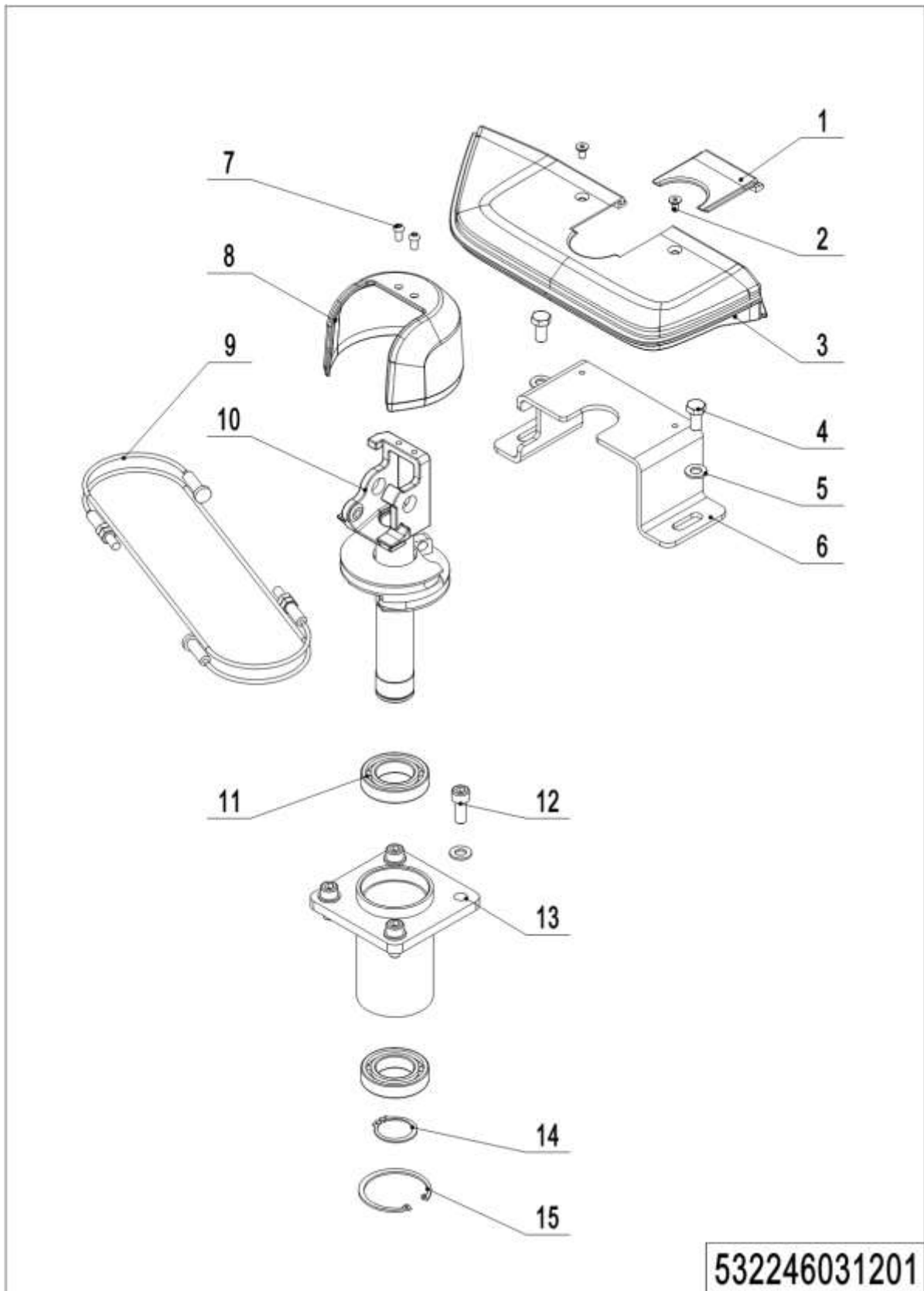
05 Manual steering (537546031201)

05 Manual steering (537546031201)

No.	Item Code	Mark	Item Description	Qty.	Substitute	Note
1	532231220011		Handle Cap	1		
2	910200400016	1	Screw	2		
3	532231220010		Handle Cap	1		
4	910100300035	1	Bolt	2		
5	910400100007	1	Flat Washer	6		
6	532231220008		Pedestal	1		
7	910200300017	1	Screw	2		
8	532211020001		Protective Cover	1		
9	532231210004		Wirerope	2		
10	532231210002		handle Spindle	1		
11	910700200007		Bearing	2		
12	910200200076	1	Screw	4		
13	532231210003		Bracket	1		
14	910401300018	1	Circlip	1		
15	910401400018	1	Circlip	1		

Chapter 5: Electrical parts and wire harness

01 Wire harness (537546033001)

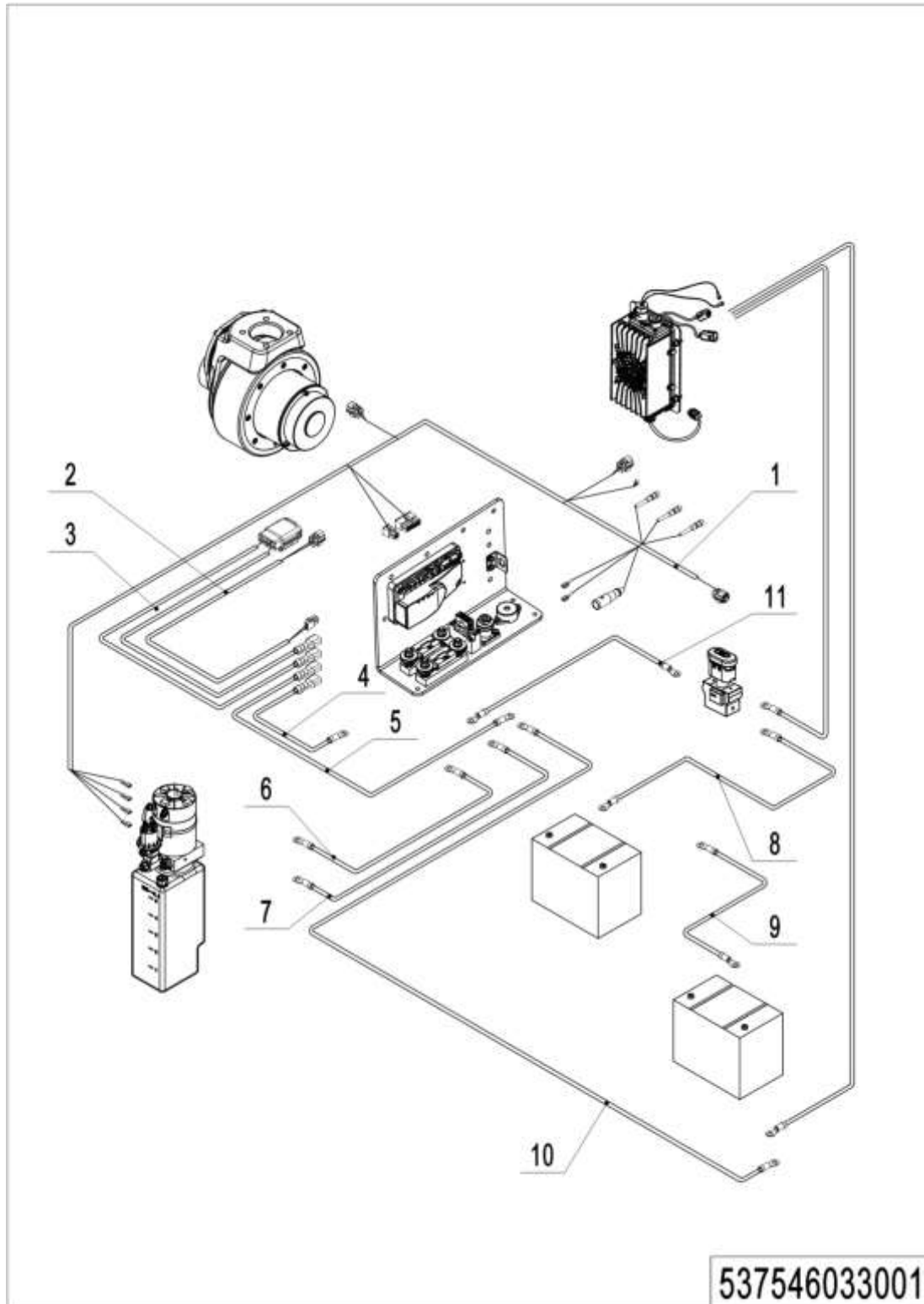

01 Wire harness (537546033001)

No.	Item Code	Mark	Item Description	Qty.	Substitute	Note
1	532233010000		Wire Harness	1		
2	532233010003		Wire Harness	1		
3	532233010004		Wire Harness	1		
4	532233010005		Cables	1		
5	532233010006		Cables	1		
6	532233010007		Cable	1		
7	532233010009		Cable	1		
8	532233010010		Cable	1		85AH
	532233010013		Cable	1		106AH
9	532233010011		Cable	1		85AH
	532233010014		Cable	1		106AH
10	532233010012		Cable	1		85AH
	532233010015		Cable	1		106AH
11	532233010016		Cable	1		

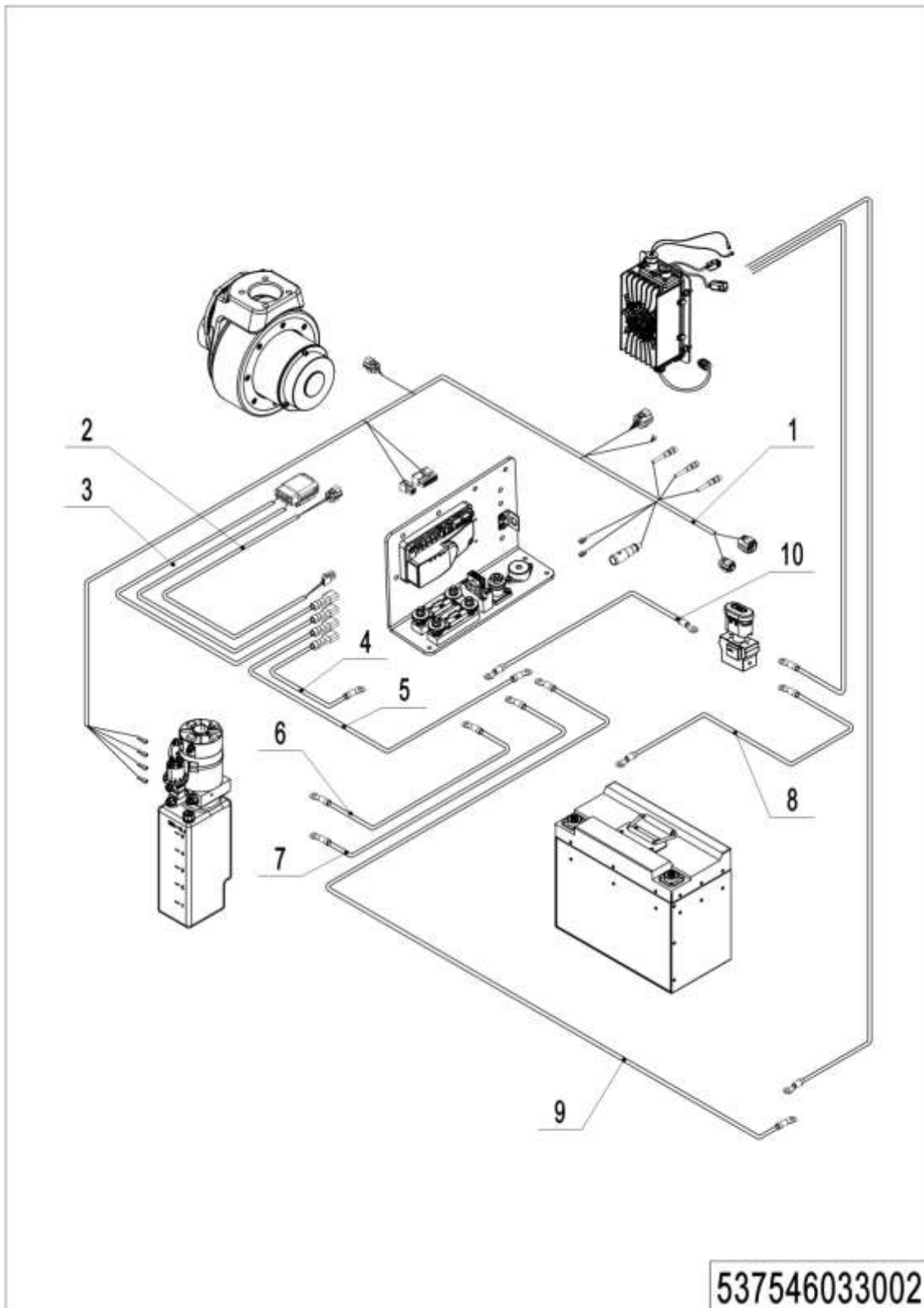
02 Wire harness (lithium battery) (537546033002)

02 Wire harness (lithium battery) (537546033002)

No.	Item Code	Mark	Item Description	Qty.	Substitute	Note
1	532233010001		Wire Harness	1		
2	532233010003		Wire Harness	1		
3	532233010004		Wire Harness	1		
4	532233010005		Cables	1		
5	532233010006		Cables	1		
6	532233010007		Cable	1		
7	532233010009		Cable	1		
8	532233010020		Cable	1		
9	532233010021		Cable	1		
10	532233010016		Cable	1		

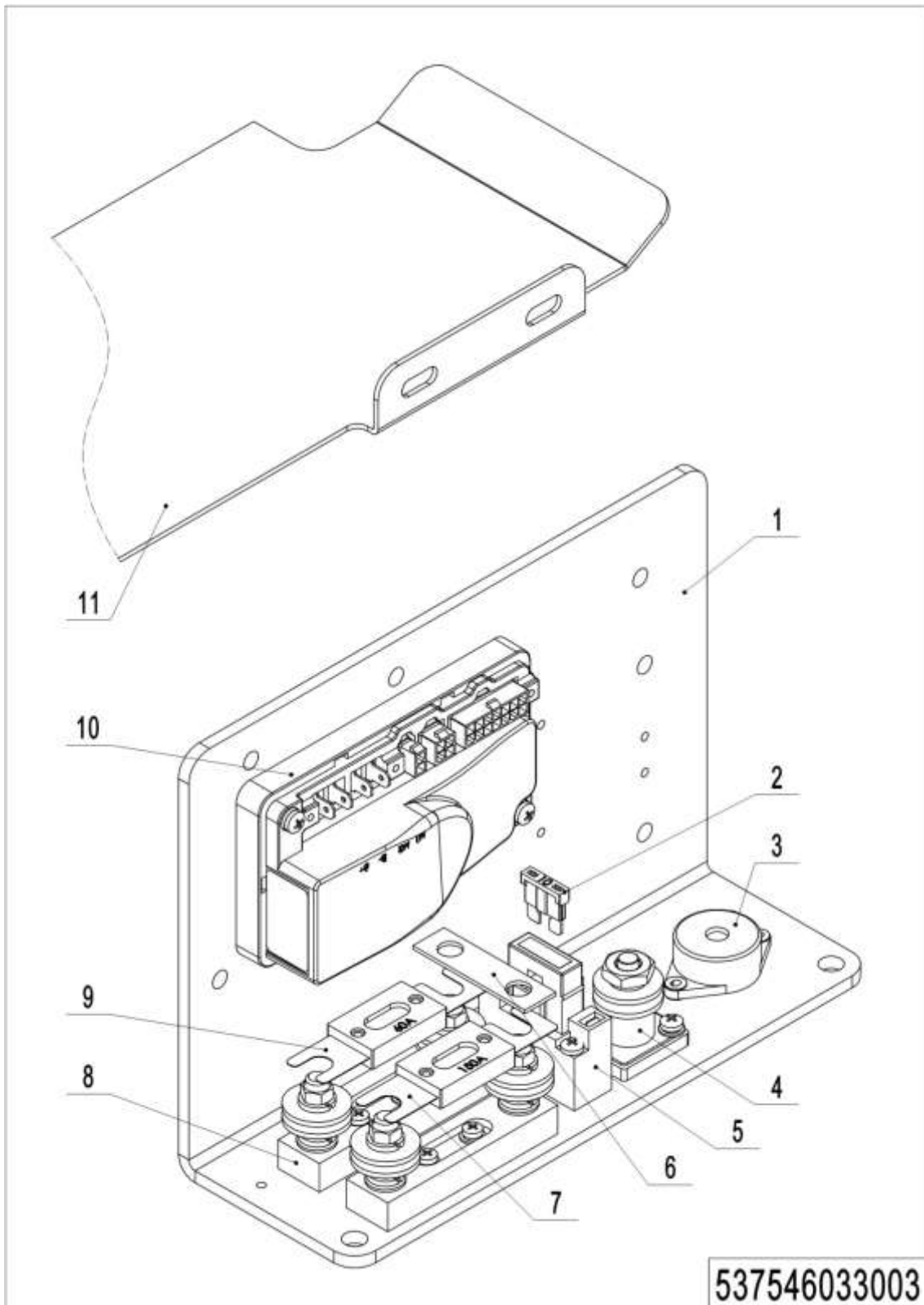
03 Electrical control unit (537546033003)

03 Electrical control unit (537546033003)

No.	Item Code	Mark	Item Description	Qty.	Substitute	Note
1	532233020001		Mounting Plate	1		
2	920100200002		Fuse	1		
3	920500100007		Horn	1		
4	920100400001		Fuse Holder	1		
5	920100400006		Fuse Holder	1		
6	505633020003		Copper Busbar	1		
7	920100100007		Fuse	1		
8	920100400002		Fuse Holder	2		
9	920100100003		Fuse	1		
10	921400100081		Controller	1		
11	532221520027		Baffle	1		

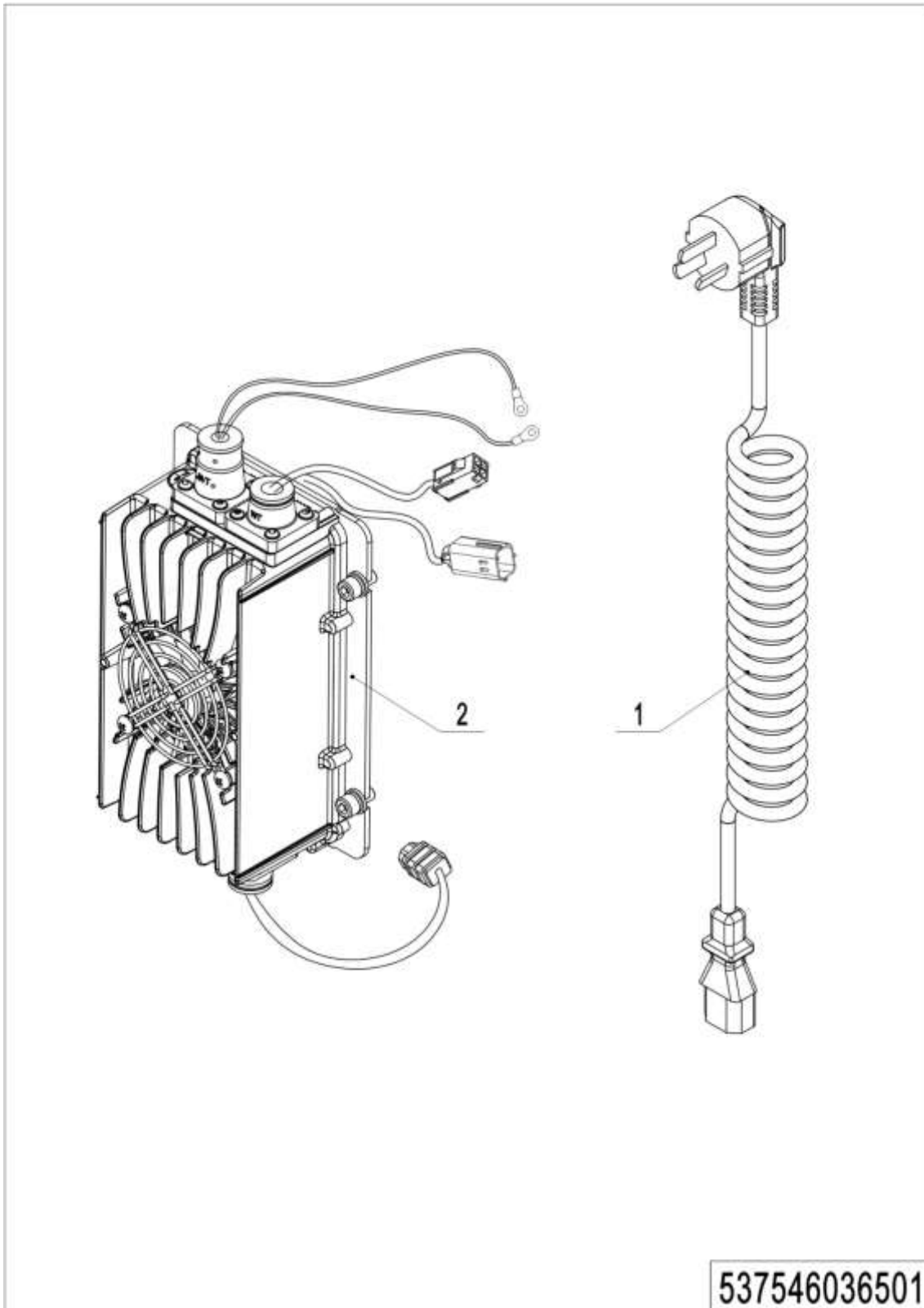
04 Charger (537546036501)

04 Charger (537546036501)

No.	Item Code	Mark	Item Description	Qty.	Substitute	Note
1	921500200008		Spring Cable (Asia)	1		
	921500200005		Spring Cable(EU)	1		
	921500200003		Spring Cable(AUS)	1		
	921500200004		Spring Cable(ENG)	1		
	921500200002		Spring Cable(USA)	1		
	921500200037		Spring Cable(ARG)	1		
	921500200006		Spring Cable(ITY)	1		
	921500200007		Spring Cable(SWD)	1		
	921500200029		Spring Cable(ISR)	1		
	921500200061		Spring Cable(BRA)	1		
2	921000100055		Charger24V12V	1		Lead-acid battery
	921000100052		Charger 24V25A	1		Lithium battery

Chapter 6: Special equipment

01 Load backrest (537546040502)

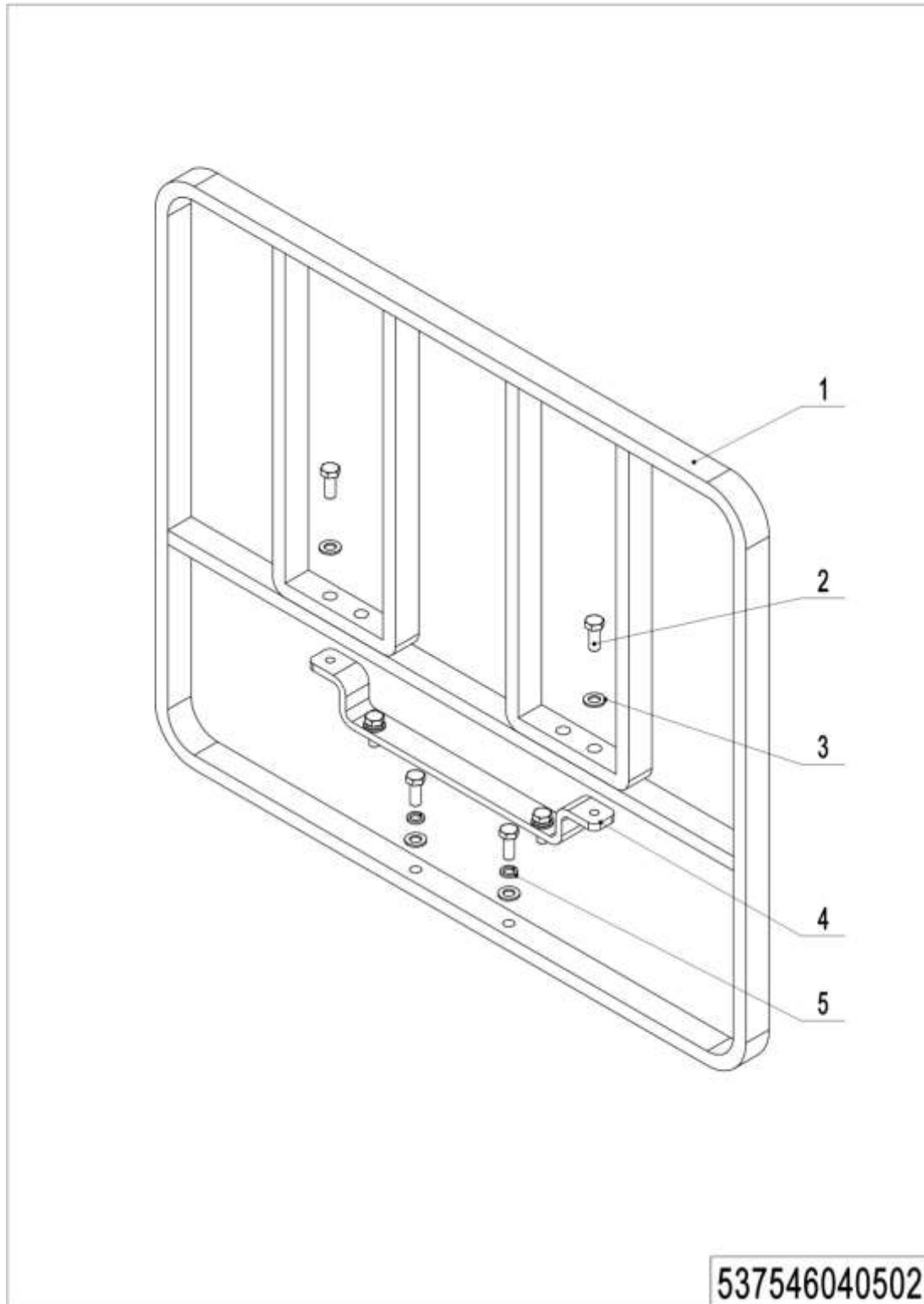

01 Load backrest (537546040502)

No.	Item Code	Mark	Item Description	Qty.	Substitute	Note
1	532640510001	2	Load Backrest	1		
2	910100300036	1	Bolt	6		
3	910400100007	1	Flat Washer	6		
4	532240520001		Division Plate	1		
5	910400500007	1	Spring Washer	4		

Chapter 7: Others

01 Labels and decals (EU) (537546047001)

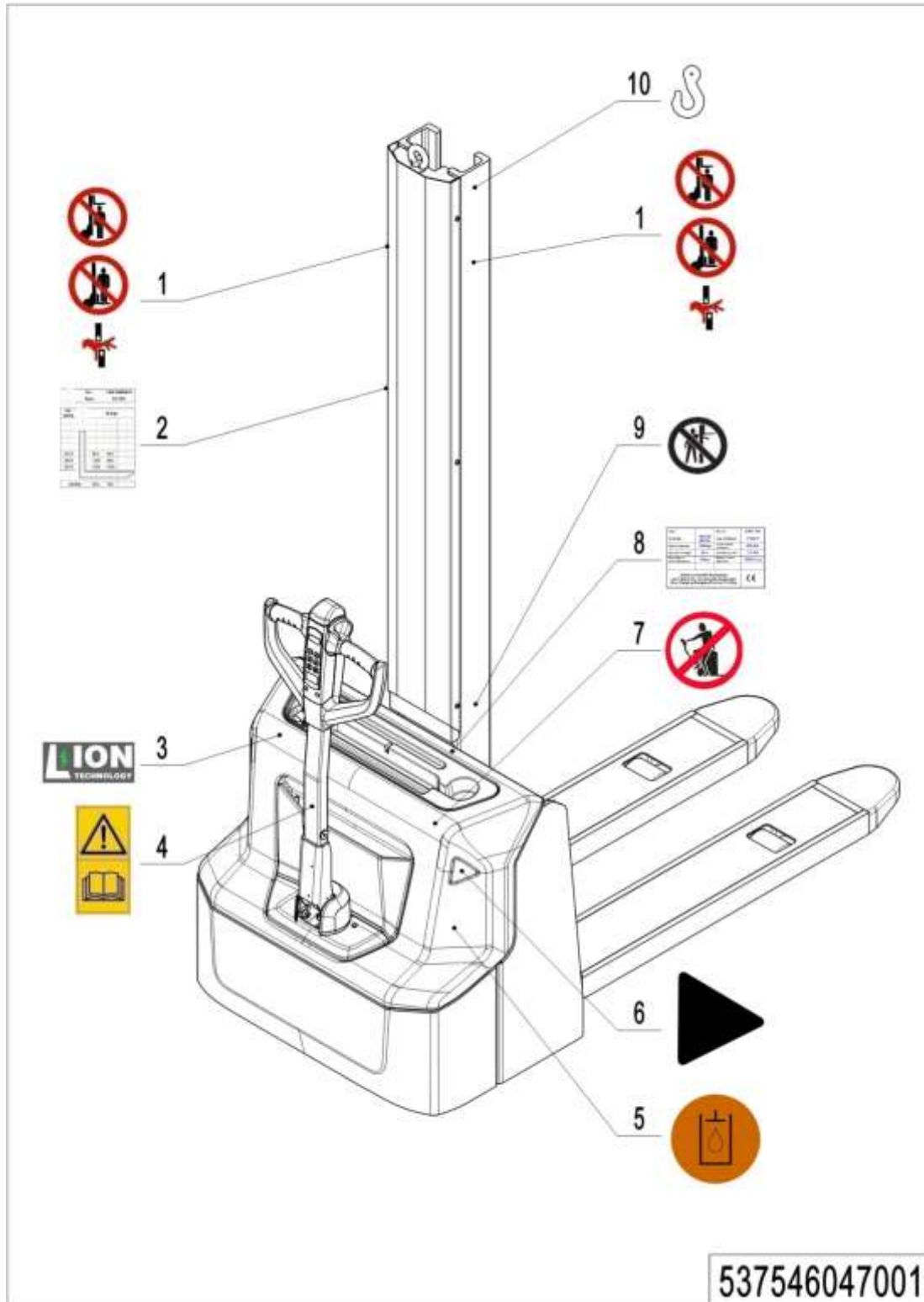

1=Supply as package; 2=Supply with limit; 3=Phasing out supply; 4=Supply as assembly; 5=Check other lists.

01 Labels and decals (EU) (537546047001)

No.	Item Code	Mark	Item Description	Qty.	Substitute	Note
1	941200100004		Label	2		
2	537547520001		Load Capacity Diagram	1		
3	532247020002		Label	1		Lithium battery
4	941200300002		Label	1		
5	941200300003		Label	1		Inside
6	532247020000		Label	2		
7	941200100003		Label	1		
8	532247520017		--	1		
9	941200100006		Label	1		
10	941200300001		Label	2		

02 Labels and decals (USA) (537546047002)

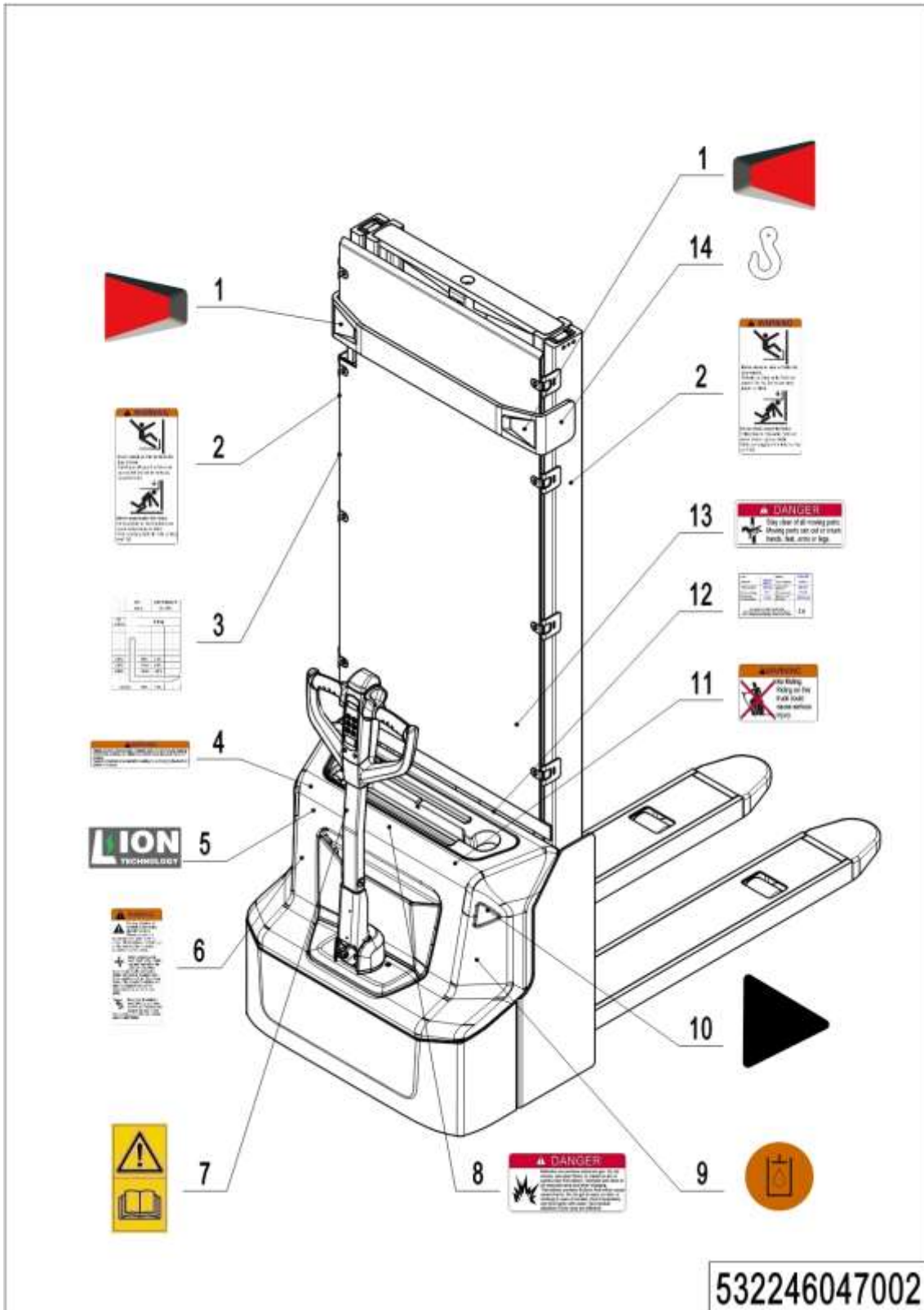

1=Supply as package; 2=Supply with limit; 3=Phasing out supply; 4=Supply as assembly; 5=Check other lists.

02 Labels and decals (USA) (537546047002)

No.	Item Code	Mark	Item Description	Qty.	Substitute	Note
1	532247020007		--	1		
2	941200100016		Label	2		
3	532247520001		Load Capacity Diagram	1		
4	941200100010		Label	1		
5	532247020002		Label	1		Lithium battery
6	941200100009		Label	1		
7	941200300002		Label	1		
8	941200100013		Label	1		
9	941200300003		Label	1		Inside
10	532247020000		Label	2		
11	941200100011		Label	1		
12	532247520017		铭牌	1		
13	941200100014		Label	1		
14	941200300001		Label	2		

Appendix

01 Electrical circuit diagram (lead-acid battery) (537546045501)

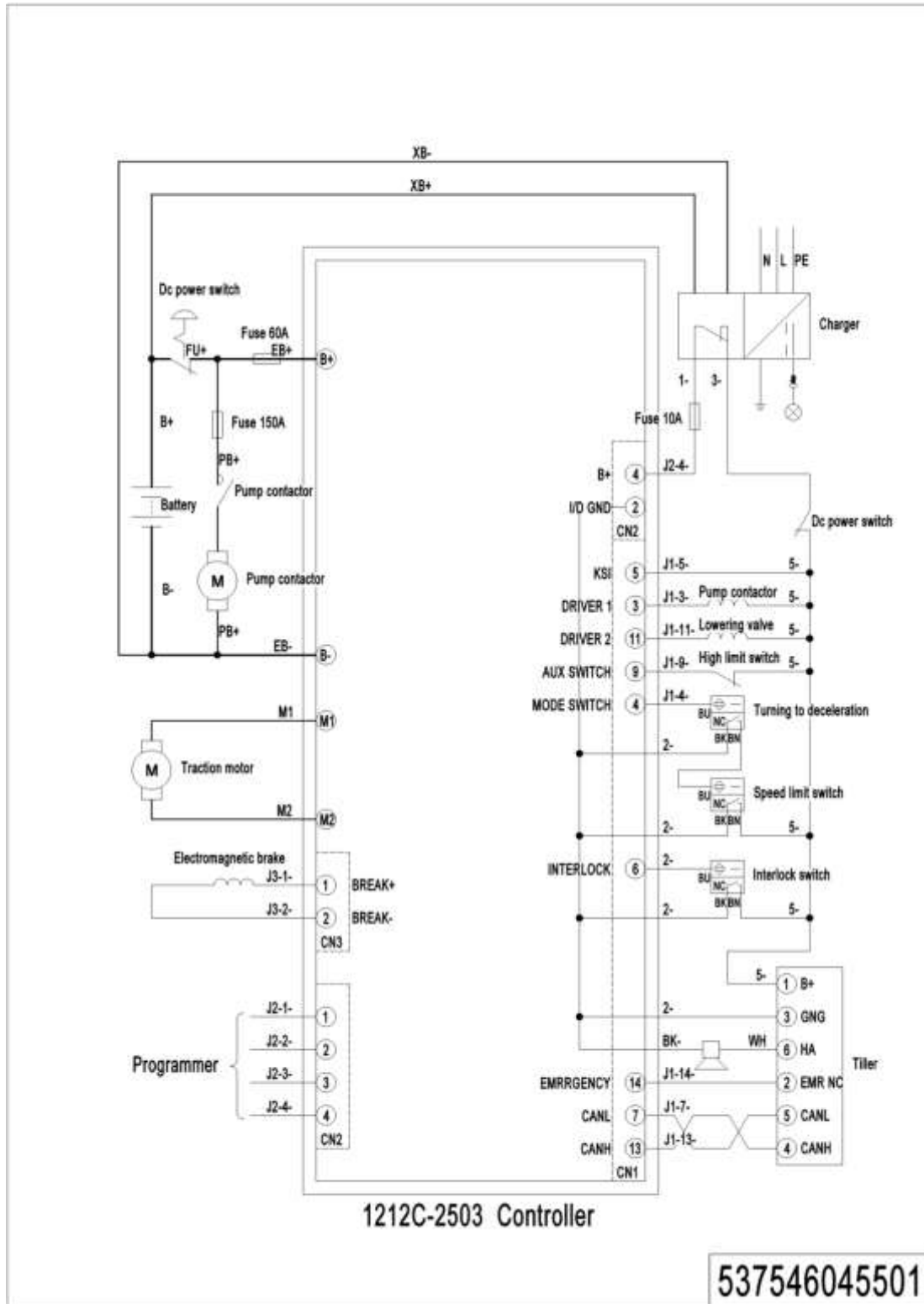

1=Supply as package; 2=Supply with limit; 3=Phasing out supply; 4=Supply as assembly; 5=Check other lists.

02 Electrical circuit diagram (Lithium battery) (537546045502)

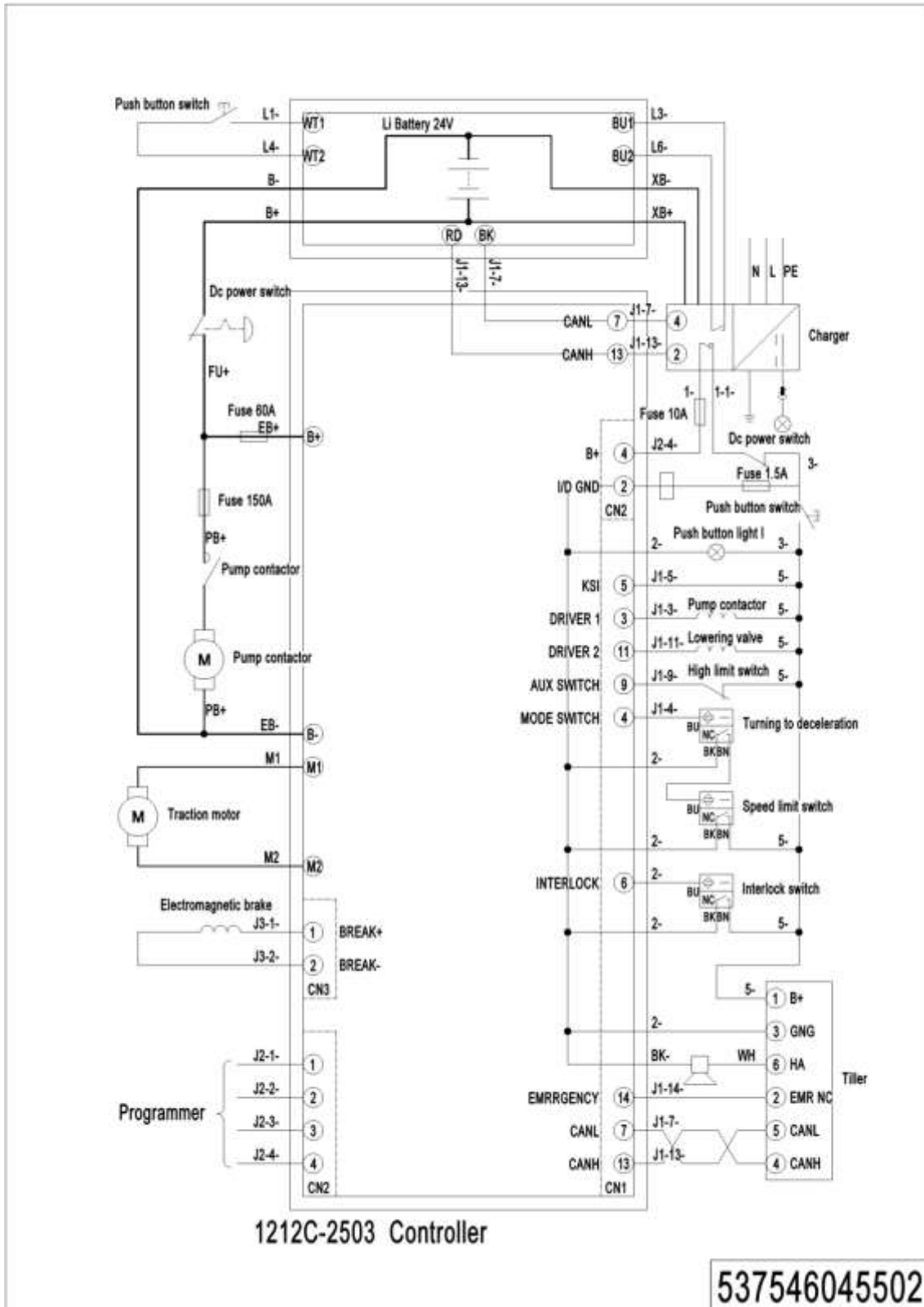

1=Supply as package; 2=Supply with limit; 3=Phasing out supply; 4=Supply as assembly; 5=Check other lists.

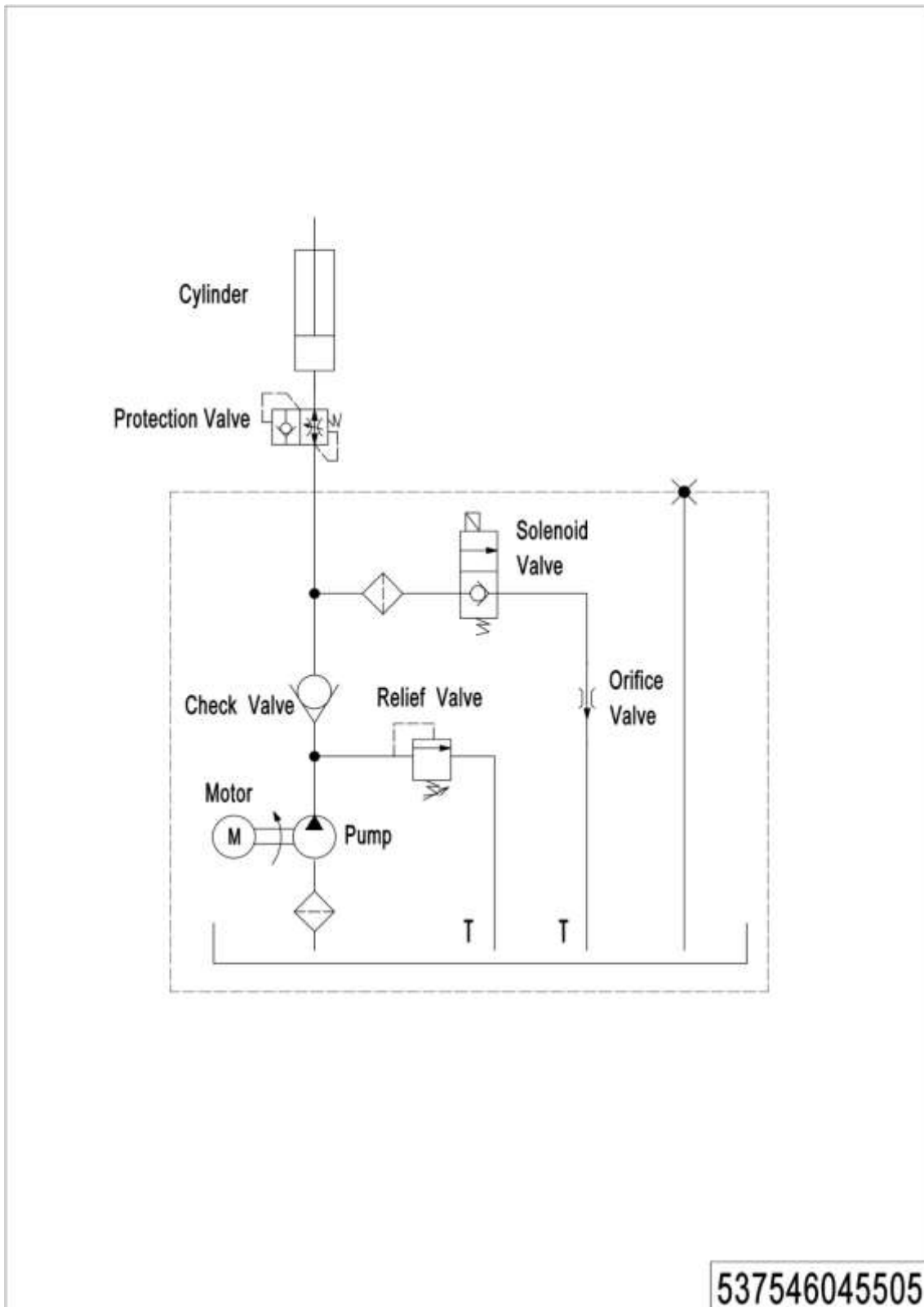
03 Hydraulic circuit diagram (537546045503)

04 Easy worn parts list

No.	Item Code	Item Description	Qty.	Chapter/ Section/ Number
1	532298510002	Seal Kit	1	Chapter 3/01/27.01
2	940500200001	Bushing	2	Chapter 4/01/6
3	532211020003	Gas Spring	1	Chapter 4/01/10.3
4	532298510003	Wheel	2	Chapter 4/03/3
5	910700200019	Bearing	4	Chapter 4/03/3.01
6	940300300011	WheelΦ84x93	2	Chapter 4/03/3.02
7	910700200019	Bearing	2	Chapter 4/04/10.02
8	910700700011	Bearing	1	Chapter 4/04/8
9	532298510004	Caster Assembly	1	Chapter 4/04/10
10	940300300030	WheelΦ100x50	1	Chapter 4/04/10.01
11	910700600001	Bearing	1	Chapter 4/04/15
12	920100100003	Fuse	1	Chapter 5/03/9
13	920100100007	Fuse	1	Chapter 5/03/7
14	920100200002	Fuse	1	Chapter 5/03/2



MOBILE INDUSTRIES, INC.
3750B Laird Rd - Unit 2 & 3
Mississauga ON, L5L 0R6
Canada

Toll Free: 1 800 527 4612 • Local 905 279 5370
Email: info@mobilept.com

MOBILEPT.COM