



## OPERATING MANUAL & PARTS LIST

# ECO I-55 STAINLESS

---

VERSION	APR 2026
MODEL	ECO I-55 STAINLESS STEEL PALLET TRUCK
APPLICABLE PRODUCTS	ECO I-55SS-HD

---

**WARNING:** Do not use the unit before reading and understanding these operating instructions.  
**NOTE:** It is highly recommended to the user of this stainless steel hand pallet truck to clean at least once a day (and mainly after use), with clear, non-salted water in order to remove all possible corrosive residue.

## ATTENTION:

- 1. The waste packages should be sorted and put into solid dustbins according to the materials and be collected disposal by local special environment protection bureau. To avoid pollution, it's forbidden to throw away the wastes randomly.**
- 2. To avoid leaking during the use of the products, the user should prepare some absorbable materials (scraps of wooden or dry duster cloth) to absorb the leaking oil in time. To avoid second pollution to the environment, the used absorbable materials should be handed in to special departments in terms of local authorities.**

Thank you for using our pallet trucks. Your pallet truck is made of high quality steel and is designed for the horizontal lifting and transport of loads on a pallet or standardized containers on a level, fixed base. For your safety and correct operation, please carefully read this instruction before using it.

**NOTE: All of the information reported herein is based on data available at the moment of printing. We reserves the right to modify our own products at any moment without notice and liability in any sanctions. So, it is suggested to always verify possible updates and changes.**

## 1. GENERAL SPECIFICATIONS

Capacity	(lbs)	4400/5500/6600
Maximum. Fork Height (mm)		200( or 190 )
Minimum. Fork Height (mm)		85( or 75 )
Fork Length	(mm)	1150 / 1220
Width Overall Forks	(mm)	520 / 540 / 685
Individual Fork Width	(mm)	160
Load Wheel Diameter	(mm)	Ø 80x70(or Ø 74x70) Nylon
Steering Wheel Diameter	(mm)	Ø 200(or Ø 180) Nylon

Special fork lengths are available in 800, 900, 950, 1000.  
Materials and specifications are subject to change without notice.

## 2. ATTACHING DRAW-BAR TO PUMP UNIT

If you have purchased a wooden box of pallet truck, some assembly is required. Certainly, you need some tools, a hammer, a pliers, a spanner, etc; and some parts, one axle with hole (105S), two elastic pins (106S)(**Note one is in the axle (105S)**), these parts are putted in a plastic bag, which is putted into the draw-bar.

**NOTE: The number of draw-bar and pump should be the same.**

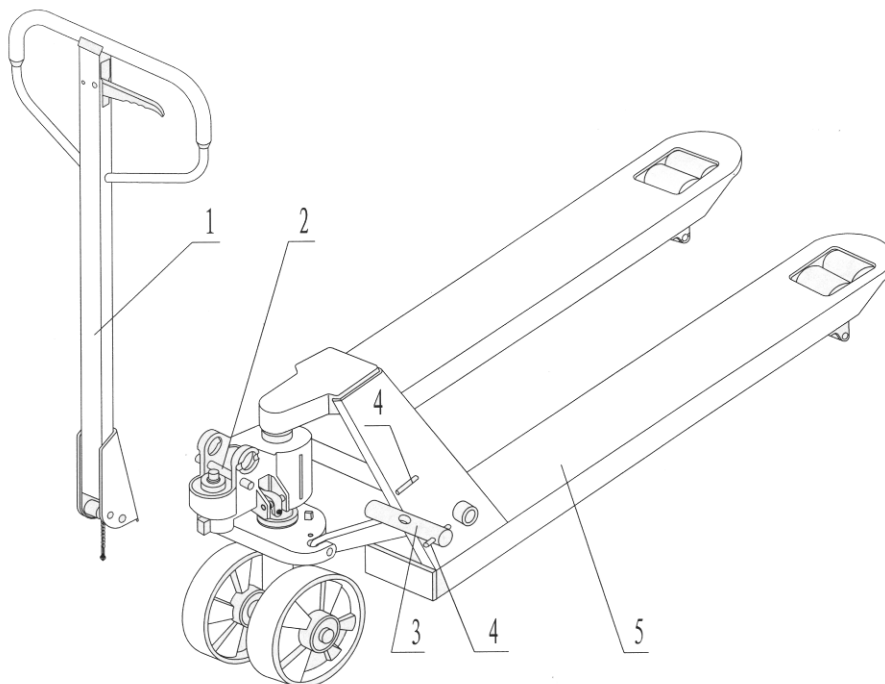

1. Draw-bar 2. Pin 3. Axle with hole 4. Elastic pin 5. Fork frame

Fig. 1

When attaching the handle, you had better squat just behind the pallet truck. Then you:

**2.1** Insert the draw-bar onto the pump piston (303), then use a hammer to insert the axle with hole (105S) into the hydraulic pump and draw-bar **from the right to left**. (See fig. 2 ).



Fig. 2

**2.2** Let control handle(117S) to the '**LOWER**' position, then pass the adjusting nut(104S), adjusting bolt(103S) and chain(102S) through the hole of axle(105S) with your hand (See fig. 3).

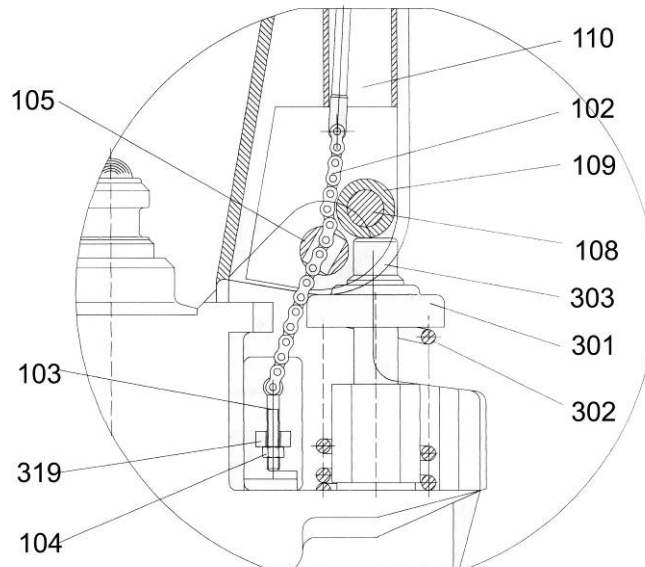

Fig. 3

**2.3** Press the draw-bar (110S) down, take away the pin(#2) (See Fig. 1).

**2.4** Let the control handle (117S) on '**RAISE**' position, then raise the lever plate (319S) with the pin (#2) and insert the adjusting bolt(103S) into the front slot of lever plate (319S), note to keep the adjusting nut (104S) on the under side of the lever plate.

**2.5** Use a hammer to tap another elastic pin (106S) into the axle with hole (105S).  
The draw-bar is now assembled to the pump.

### 3. ADJUSTING RELEASE DEVICE

On the draw-bar of this pallet truck, you can find the control handle(117S) which can be adjusted in three positions :

- Raise** -handle down
- Drive** -handle in center position
- Lower** -handle up, the lever moves back the drive position when released.

If however they have been changed, you can adjust according to following step:

**3.1** If the forks elevate while pumping in the **DRIVE** position, turn the adjusting nut (104S) on the adjusting bolt(103S) or screw(318S) clockwise until pumping action does not raise the forks and

the **DRIVE** position functions properly.

- 3.2 If the forks descend while pumping in the **DRIVE** position, turn the nut(104S) or screw(318S) counter-clockwise until the forks do not lower.
- 3.3 If the forks do not descent when the control handle (117S) is in the **LOWER** position, turn the nut(104S) or screw (318S) clockwise until raising the control handle(117S) lowers the forks. Then check the **DRIVE** position according to item 3.1 and 3.2 to be sure the nut (104S) and screw(318S) is in the proper position.
- 3.4 If the forks do not elevate while pumping in the **RAISE** position, turn the nut (104S) or screw (318S) counter-clockwise until the forks elevate while pumping in the **RAISE** position. Then check the **LOWER** and **DRIVE** position according to item 3.1, 3.2 and item 3.3.

## 4. MAINTENANCE

The pallet truck is largely maintenance-free.

### 4.1 OIL

Please check the oil level every six months. The oil can be hydraulic oil: ISO VG32, its viscosity should be 30cSt at 40<sup>0</sup> C, total volume is about 0.4lt.

### 4.2 TO BANISH THE AIR

The air may come into the hydraulic oil because of transportation or pump in upset position. It can cause that the forks do not elevate while pumping in the **RAISE** position. The air can be removed in the following way: let the control handle (117S) on the **LOWER** position, then move the draw-bar up and down for several times.

### 4.3 DAILY CHECK AND MAINTENANCE

Daily check of the pallet truck can limit wear as much as possible. Special attention should be paid to the wheels, the axles, as thread, rags, etc. It may block the wheels. The forks should be unloaded and lowered in the lowest position when the job is over.

### 4.4 LUBRICATION

All bearings and shafts are provided with long-life grease at the factory. You only need provide with long-life grease at monthly intervals or after each time the truck is cleaned thoroughly to the lubrication points.

## 5 GUIDE TO SAFETY OPERATION

- 5.1 Operator should read all warning signs and instructions here and on the pallet truck before using this truck.
- 5.2 Do not use on a slopping ground.
- 5.3 Do not operate a pallet truck unless you are familiar with it and have been trained or authorized to do so.
- 5.4 Do not operate a pallet truck unless you have checked its condition. Give special attention to the wheels or rollers, the draw-bar unit, the fork unit, the lever plate, etc. .
- 5.5 To pull the truck, always move the control handle into the drive position. This makes the draw-bar easier to move and depressurizes the pump section of the hydraulics. This preserves the hydraulic seals and the valve components. A long service life can be expected.
- 5.6 Do not take up any people on the pallet truck.
- 5.7 The operator had better take on gloves for labor protecting.

5.8 When the goods have been transported, all people should be away from the forks for 600mm.

5.9 Do not load goods like fig. 5/B .

5.10 Do not load over maximum capacity.

5.11 At others special condition or place, the operator should be carefully to operate the pallet truck.

## 6. TROUBLESHOOTING

No	Trouble	Clause	Fixing Methods
1	The forks can not be lifted up the maximum height.	The hydraulic oil is not enough.	Pour in the oil.
2	The forks can not be lifted up.	Without hydraulic oil. The oil has impurities. The nut (104S) is too high, keep the pumping valve open. Air come into the hydraulic oil.	Fill in the oil. Change the oil. Adjust the nut(104S) or screw (318S) (see item 3.4) Banish the air.(see item 4.2)
3	The forks can not be lowered.	The piston rod(328) or pump (322S) is deformed resulting from partial loading slanting to one side or over-loading. The fork was kept in the high position for long time with piston rod bared to arise in rusting and jamming of the rod. The adjusting nut (104S) or screw (318S) is not in correct position.	Replace the piston rod (328) or pump (322S). Keeping the fork in the lowest position if not using, and pay more attention to lubricate the rod. Adjust the nut (104S) or screw (318S) (see item 3.3)
4	Leaks	Sealing parts worn or damaged. Some part cracked or worn into small.	Replace with the new one. Replace with the new one.
5	The forks lowered without the release valve working.	The impurities in the oil cause the release valve to be unable to close tight. Some parts of hydraulic system is cracked or bored. Air come into the oil. Sealing parts worn or damaged. The adjusting nut (104S) or screw (318S) is not in the correct position.	Replace with new oil. Inspect and replace the waste parts. Banish the air. (See item 4.2) Replace with the new one. Adjusting the nut (104S) or screw (318S). (See item 3.2)

**NOTE: DO NOT ATTEMPT TO REPAIR THE PALLET TRUCK UNLESS YOU ARE TRAINED AND AUTHORIZED TO DO SO.**

Fig. 4

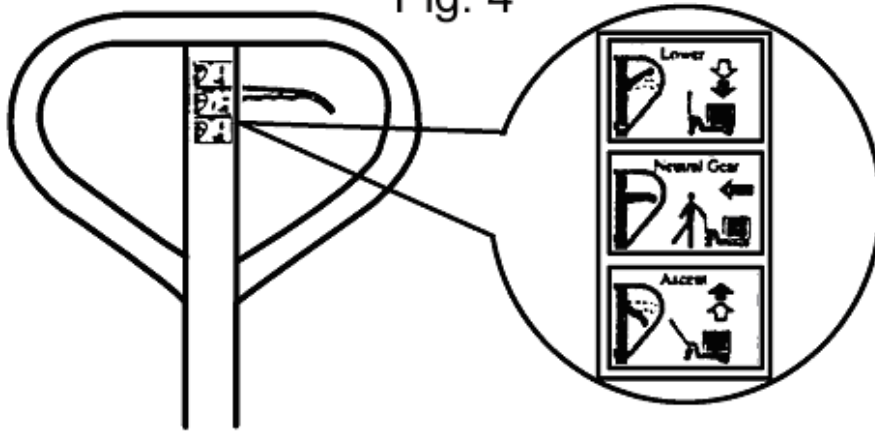
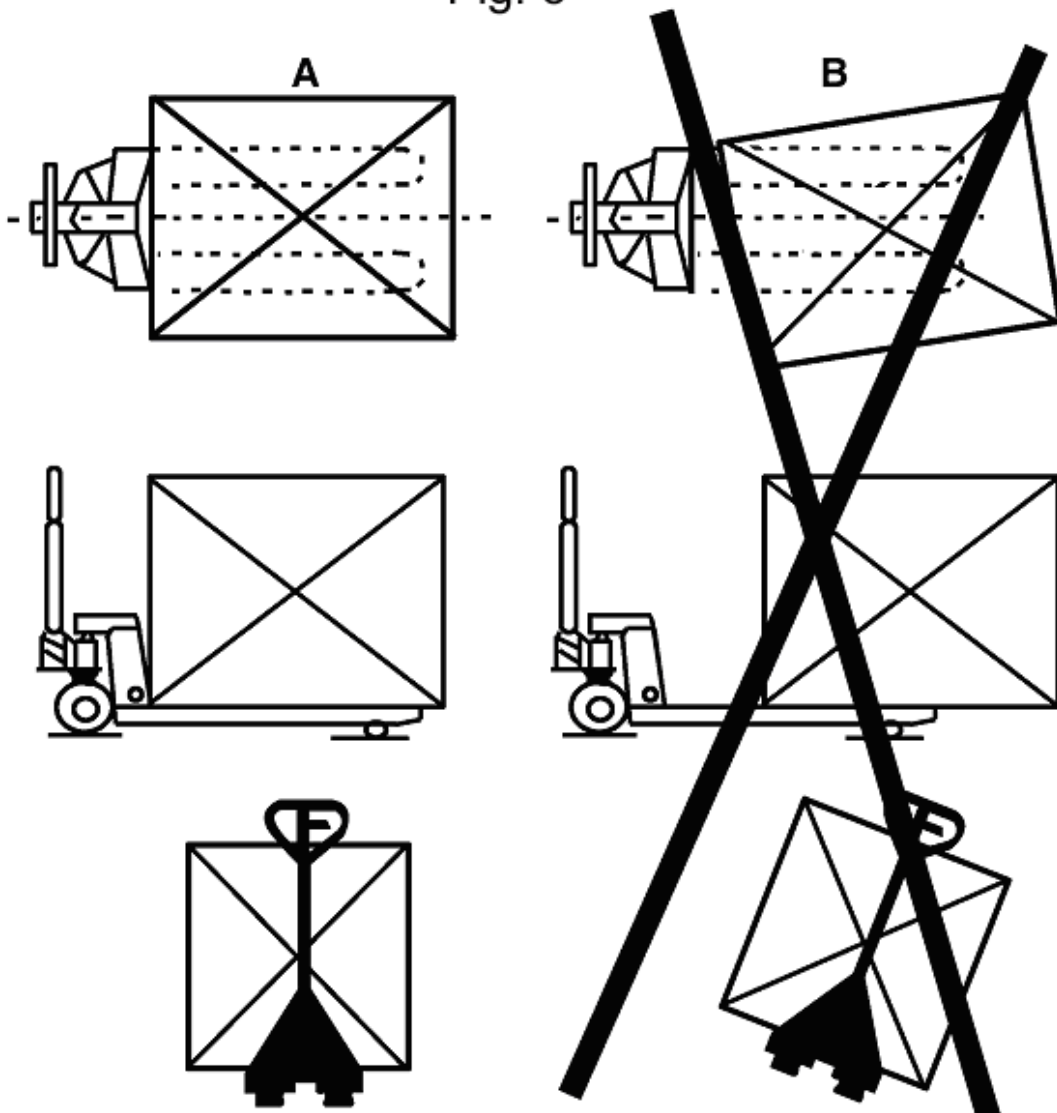
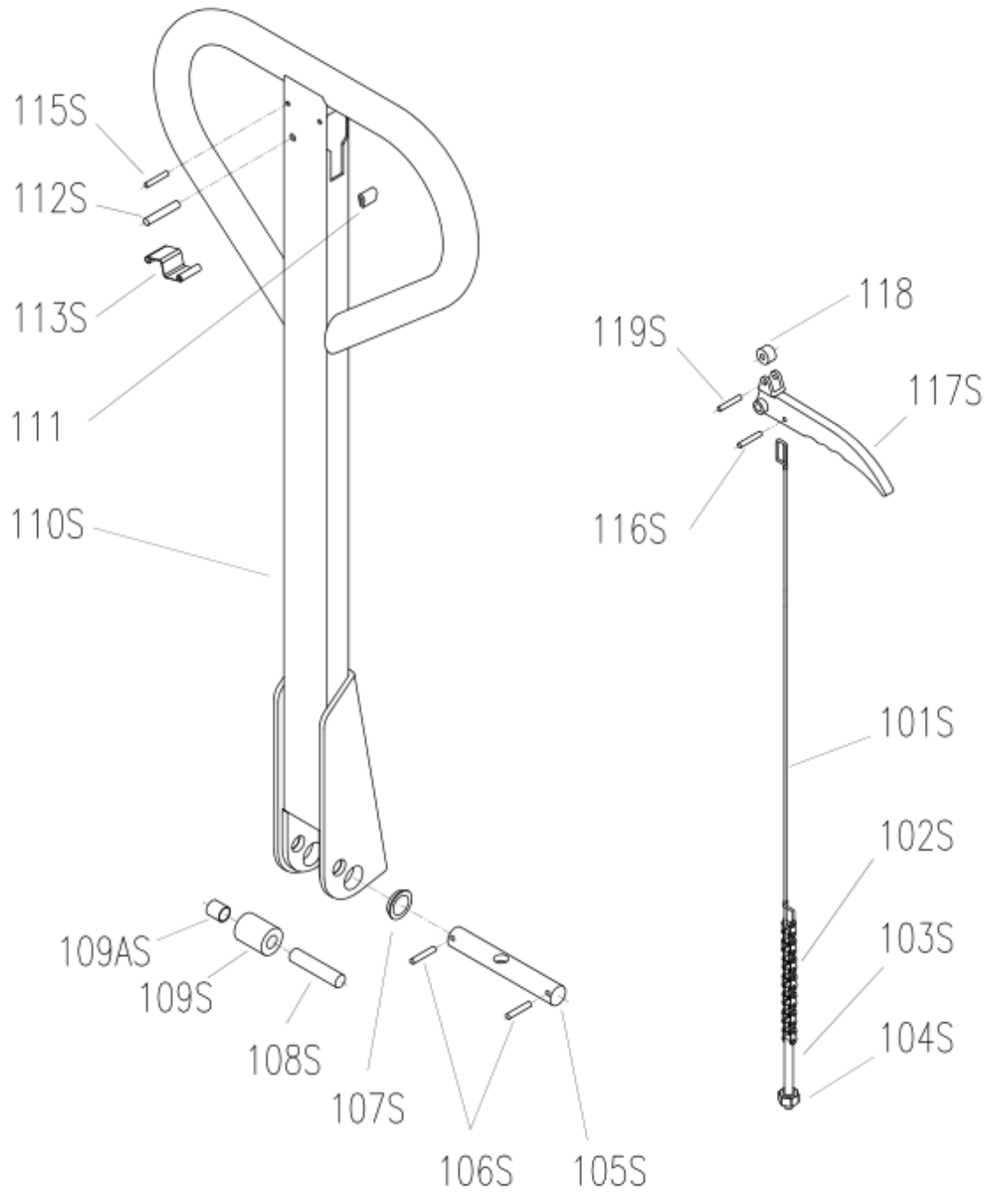

Fig. 5





## LIST of DRAW-BAR

No.	Description	Qty.	Material Make-Up	
			Type 304	Type 316
101S	Release Rod	1	304	316
102S	Chain	1	304	304
103S	Adjusting Bolt	1	304	316
104S	Adjusting Nut	1	304	316
105S	Axle with Hole	1	304	316
106S	Elastic Pin	2	304	304
107S	Bushing	2	304	304
108S	Roller Pin	1	304	316
109S	Pressure Roller	1	304	316
109AS	Bushing	1	304	304
110S	Draw-bar	1	304	316
111	Stop Rubber	1	Rubber	Rubber
112S	Elastic Pin	1	304	304
113S	Blade Spring	1	3Cr13	3Cr13
115S	Elastic Pin	1	304	304
116S	Elastic Pin	1	304	304
117S	Control Handle	1	304	316
118	Roller	1	Plastic	Plastic
119S	Elastic Pin	1	304	304
120S				

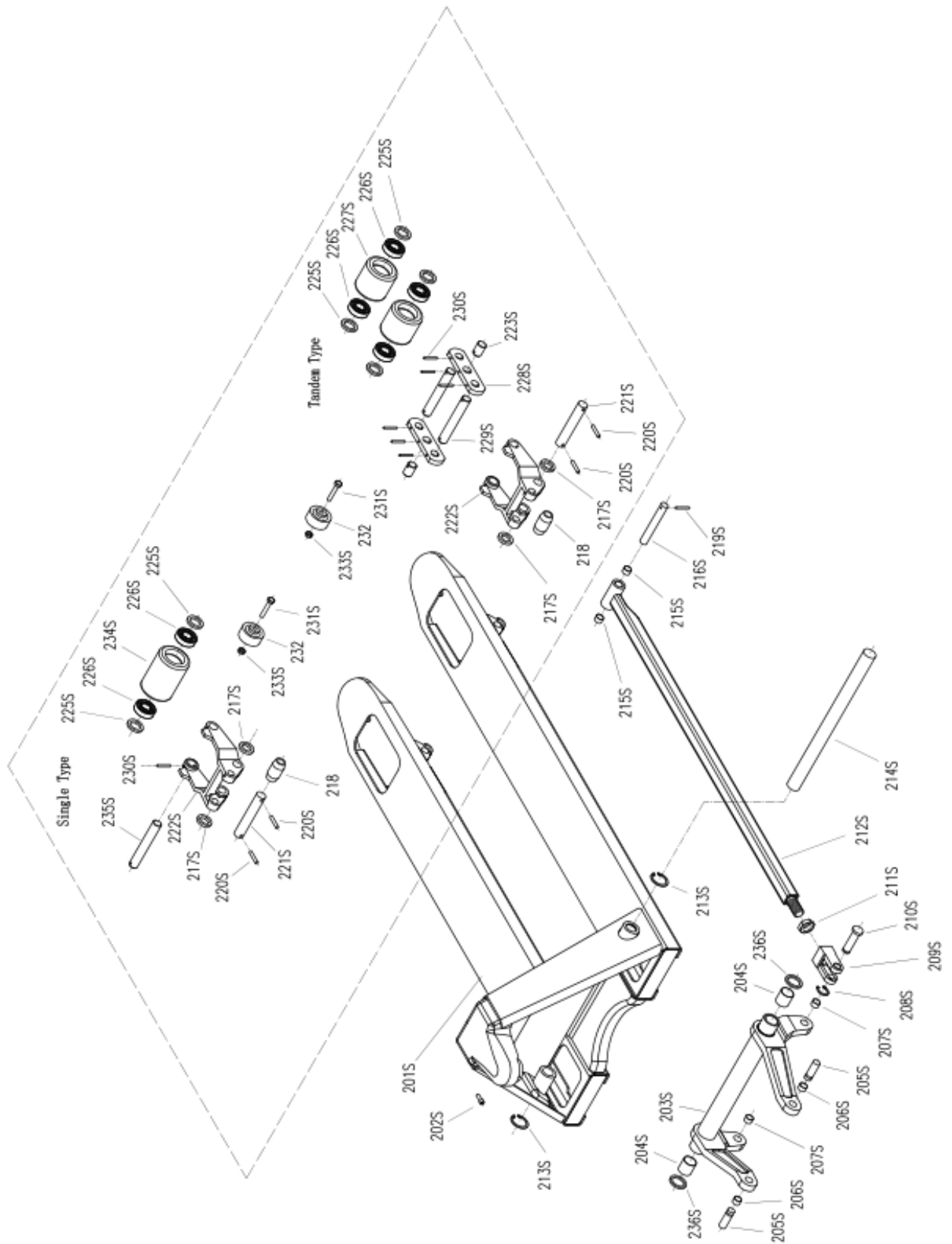

**LIST of FORK FRAME**

No.	Description	Qty.	Material Make-Up	
			Type 304	Type 316
201S	Fork Frame	1	304	316
202S	Bolt	1	304	304
203S	Rock - Arm	1	304	316
204S	Bushing	2	304	304
205S	Shaft	2	304	316
206S	Bushing	2	304	304
207S	Bushing	2	304	304
208S	Retaining Ring	2	304	304
209S	Joint	2	304	316
210S	Pin	2	304	316
211S	Nut	2	304	316
212S	Pushing Rod	2	304	316
213S	Retaining Ring	2	304	304
214S	Shaft	1	304	316
215S	Bushing	4	304	304
216S	Shaft	2	304	316
217S	Intermediate Roller	4	Plastic	Plastic
218	Extending Roller	2	Plastic	Plastic
219S	Elastic Pin	2	304	304
220S	Elastic Pin	4	304	304
221S	Shaft	2	304	316
222S	Frame of Roller	2	304	316
223S*	Shaft	4	304	316
224S*				
225S	Washer	8 or 4	304	316
226S	Bearing	8 or 4	304	304
227S*	Loading Roller	4	Nylon	Nylon
228S-N*	Link plate	4	304	316
229S-N*	Shaft for roller	4	304	304
230S	Elastic Pin	12 or 2	304	304
231S	Bolt	2	304	316
232	Enter Roller	2	Plastic	Plastic
233S	Locking Nut	2	304	304
234S#	Loading Roller	2	Nylon	Nylon
235S#	Shaft for Roller	2	304	316
236S	Washer	2	304	316

**NOTE: \*-- For double wheel;#-- For single wheel**

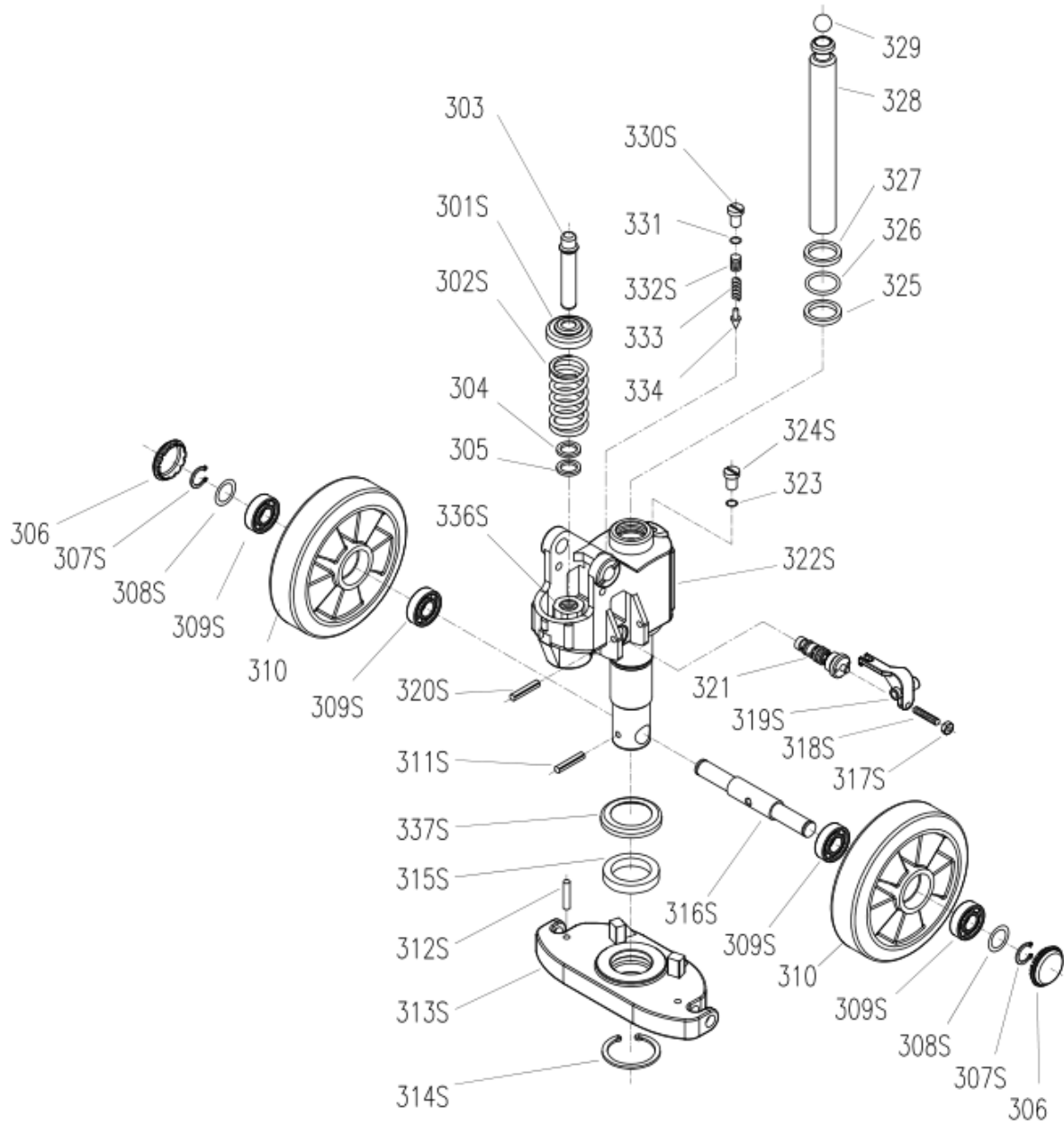

### LIST of HYDRAULIC PUMP

No.	Description	Qty.	Material Make-Up	
			Type 304	Type 316
301S	Spring Cap	1	304	304
302S	Spring	1	304	316
303	Pump Piston	1	Steel	304
304	Dust Ring	1	PU	PU
305	Seal	1	PU	PU
306	Dust Cover	2	Plastic	Plastic
307S	Locking Ring	2	304	304
308S	Washer	2	304	316
309S	Bearing	4	304	304
310	Loading Wheel	2	Nylon	Nylon
311S	Elastic Pin	1	304	304
312S	Elastic Pin	2	304	304
313S	Thrust Plate	1	304	316
314S	Retaining Ring	1	304	304
315S	Bearing	1	304	304
316S	Shaft of loading Wheel	1	304	316
317S	Nut	1	304	316
318S	Screw	1	304	316
319S	Lever Plate	1	304	316
320S	Elastic Pin	1	304	304
321	Valve Cartridge	1	Kits	Kits
322S	Pump Body	1	304	316
323	Seal Washer	1	Rubber	Rubber
324S	Screw Plug	1	304	316
325	Seal	1	Pu	PU
326	O – Ring	1	Rubber	Rubber
327	Dust Ring	1	PU	PU
328	Piston Rod	1	Steel	304
329	Steel Ball	1	304	304
330S	Screw Plug	1	304	316
331	O - Ring	1	Rubber	Rubber
332S	Bolt	1	304	316
333	Spring	1	Steel	Steel
334	Spindle of Safety Valve	1	Steel	Steel
336S	Cylinder	1	304	316
337S	Cover of Bearing	1	304	316



**MOBILE INDUSTRIES, INC.**  
3750B Laird Rd - Unit 2 & 3  
Mississauga ON, L5L 0R6  
Canada

Toll Free: 1 800 527 4612 • Local 905 279 5370  
Email: [info@mobilept.com](mailto:info@mobilept.com)

**MOBILEPT.COM**